

KZN Submersible Sump Pumps for Abrasive Slurry Service



5 to 30 HP – Flow rates to 1600 GPM

These heavy-duty submersible pumps are designed to tackle the toughest conditions. An agitator stirs up sand, solids and slurries to prevent the pump from clogging. The KZN pumps are made from high quality steel materials. It features heavy-duty wear resistant impellers, agitators and dual mechanical seals.

Features:

- * Heavy duty construction
- * Top discharge
- * Water jacket with axial flow cooling
- * Built in agitator, which stirs up the solids into a suspended state.
- * Large particle handling capability
- * Hard chromium impeller and agitator
- * Dual mechanical seals:
Lower SICx2 ; Upper CER/CRB
- * Insulation - Class H

Applications:

- * Muddy water
- * Agricultural waste
- * Barge unloading
- * Mill scale
- * Dredging; Construction
- * Mine Tailings
- * Coal oil runoff
- * Fly ash
- * Coke fires
- * Sewer system drainage
- * Settling ponds

KTH Sales, Inc.
8574 Louisiana Place
Merrillville, Indiana 46410
Ph: 219-736-0060 – Fax: 219-769-0263
www.KTHSales.com -- sales@KTHSales.com

Specifications

Model Number:	KZN37	KZN55&H	KZN75	KZN110&H	KZN150	KZN220
Electrical Submersible Pump	Yes	Yes	Yes	Yes	Yes	Yes
Discharge Connection						
3" Male NPT.	Yes	N/A	Yes	N/A	N/A	N/A
4" Male NPT.	N/A	Yes	Yes	Yes	N/A	N/A
6" Male NPT.	N/A	N/A	N/A	Yes	Yes	Yes
Double Mechanical Seals: Upper - Carbon/Ceramic Lower - Sil-carbide/Sil-carbide Motor Casing - Cast Iron Pump housing - Cast iron Wear Plate - High Hard Agitator - High Hard Lipseal Buna N: Impeller - High Hard Strainer - Steel Rotor Shaft - 304 Stainless Steel	Yes	Yes	Yes	Yes	Yes	Yes
Hardware: 304 Stainless Steel	Yes	Yes	Yes	Yes	Yes	Yes
Motor Rating HP:	5	7.5	10	15	20	30
Voltage:						
230V, 3Phase 60 cycle *	Yes	Yes	Yes	Yes	N/A	N/A
460V, 3Phase 60 cycle *	Yes	Yes	Yes	Yes	Yes	Yes
Current (F.L. Amps): 230/460	13.5/6.8	19.5/9.5	26/13	35/17.5	50/25	72/36
Thermal Overload:	Yes	Yes	Yes	Yes	Yes	Yes
R.P.M. 1750	Yes	Yes	Yes	Yes	Yes	Yes
Qty. Oil in Seal Chamber	N/A	N/A	N/A	N/A	N/A	N/A
Power Cord Length:	50'	50'	50'	50'	50'	50'
Maximum Height:	32.3"	32.3"	33.1"	43.3"	45.1"	52.2"
Maximum Width:	16.5"	16.5"	16.5"	21.4"	21.4"	22.7"
Weight: Lbs.	243	265	287	529	616	880

KZN Performance Curve

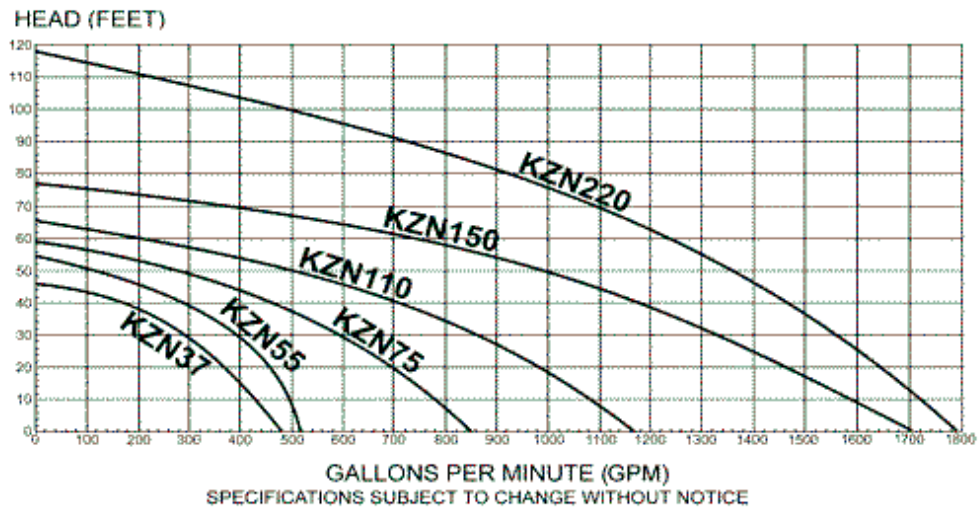

KZN PUMP CURVES 55H, 110H Submersible Pumps

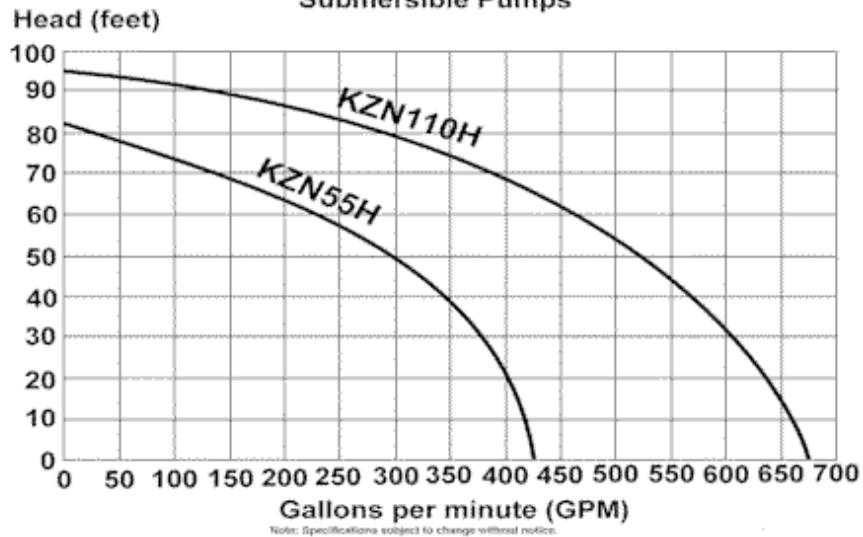

Performance is 60 HZ - 1750 RPM

KTH Sales, Inc.
8574 Louisiana Place
Merrillville, Indiana 46410
Ph: 219-736-0060 - Fax: 219-769-0263
www.KTHSales.com -- sales@KTHSales.com

KZN Dimensions

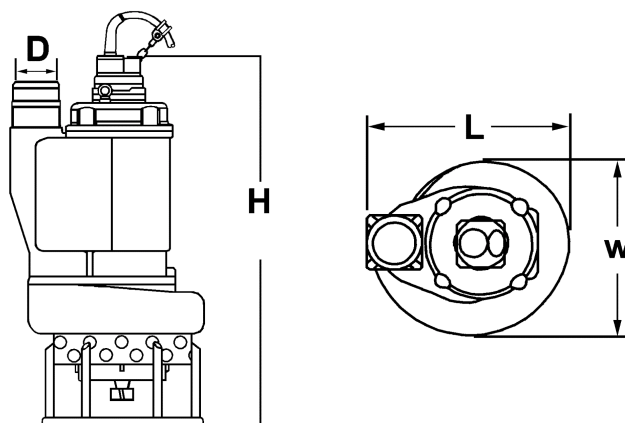

Model	D	H	L	W
KZN37	3"	32.3	16.5	16.1
KZN55	3-4"	32.3	16.5	16.1
KZN55H	3-4"	31.1	16.5	16.1
KZN75	3-4"	33.1	16.5	16.1
KZN75H	3-4"	32.3	16.5	16.1
KZN110	6"	43.3	22.4	22.0
KZN100H	4"	43.3	22.4	22.0
KZN150	6"	45.1	22.4	22.0
KZN220	6"	52.2	22.8	21.4

All dimensions in inches

KZN Series pumps use an agitator on the suction to suspend solids to allow pumping.

KTH Sales, Inc.
8574 Louisiana Place
Merrillville, Indiana 46410
Ph: 219-736-0060 – Fax: 219-769-0263
www.KTHSales.com -- sales@KTHSales.com