

BJM CORP.

123 Spencer Plains Road,
P.O. BOX 1138, Old Saybrook, CT 06475, USA
(860) 399-5937 · (800) 442-2562 · Fax: (860) 399-7784
Visit our web site: www.bjmcop.com

10/30/2002

0802

Supersedes

0801

TECHNICAL DATA MODEL SK110C BJM SHREDDER PUMP-CAST IRON

GENERAL DATA

MAX. FLOW: GPM (L/min)	845 GPM (3198 L/min)
MAX. HEAD: ft (m)	94' (28.6 m)
SOLID SIZE: in (mm)	3" (76.2 mm)
IMPELLER DIAMETER: in (mm)	10.04" (255 mm)
DISCHARGE SIZE	6" NPT-FEMALE
SLIDE RAIL DISCHARGE SIZE	6"
PUMP NET WEIGHT ¹ : lbs (kg)	497 lbs (225 kg)
SHIPPING WEIGHT: lbs (kg)	605 lbs (275 kg)

1- Does not include power cord.

CONSTRUCTION/MATERIAL DATA

MECHANICAL SEAL - UPPER	CARBON/CERAMIC
MECHANICAL SEAL - LOWER	SILICON CARBIDE/SILICON CARBIDE
MOTOR HOUSING	304 SS
PUMP VOLUTE	CAST IRON
IMPELLER	DOUBLE VANE, CAST IRON
IMPELLER SHREDDER BLADE	TUNGSTEN CARBIDE
SUCTION COVER	CAST IRON, HARDENED
STAND	CAST IRON
LIPSEAL & O-RINGS	BUNA-N
ROTOR SHAFT	304 SS
EXTERNAL HARDWARE	304 SS
QTY. OIL IN SEAL CHAMBER	108.2 U.S. FL. OZ. (3200 C.C.)
BALL BEARING: PERM. LUBE. UPPER	6306
BALL BEARING: PERM. LUBE. LOWER	6309 x 2

ELECTRICAL /MOTOR DATA

MOTOR: TYPE, RATING HP	SUBMERSIBLE, 15
MOTOR RPM	1750
MOTOR INSULATION CLASS	H
MOTOR SERVICE FACTOR	1.1
VOLTAGE ²	230/460, 3 PH, 60 Hz ; OPTION 208V/3PH/60Hz
CURRENT F.L.A. AT 230/460 V	39.6/19.8
MOTOR PROTECTION	THERMAL & AMP. OVERLOAD
POWER CORD ³ : GAGE; LENGTH	A.W.G. 8/4; 33' (10m)
MAXIMUM LIQUID TEMPERATURE	104°F (40°C)
MAXIMUM STATOR TEMPERATURE	230°F (110°C)
SEAL LEAK DETECTOR ⁴	SEAL MINDER; MOISTURE SENSING PROBE

2- Available in other voltages (and in 50 Hz).

3- Available in 5 leads cable(3 phase power only) and different length.

4- Requires a circuit in control panel for warning signal.

REFER TO REVERSE SIDE FOR PUMP PERFORMANCE CURVES
SPECIFICATIONS SUBJECT TO CHANGE WITHOUT NOTICE

MODEL: SK110C

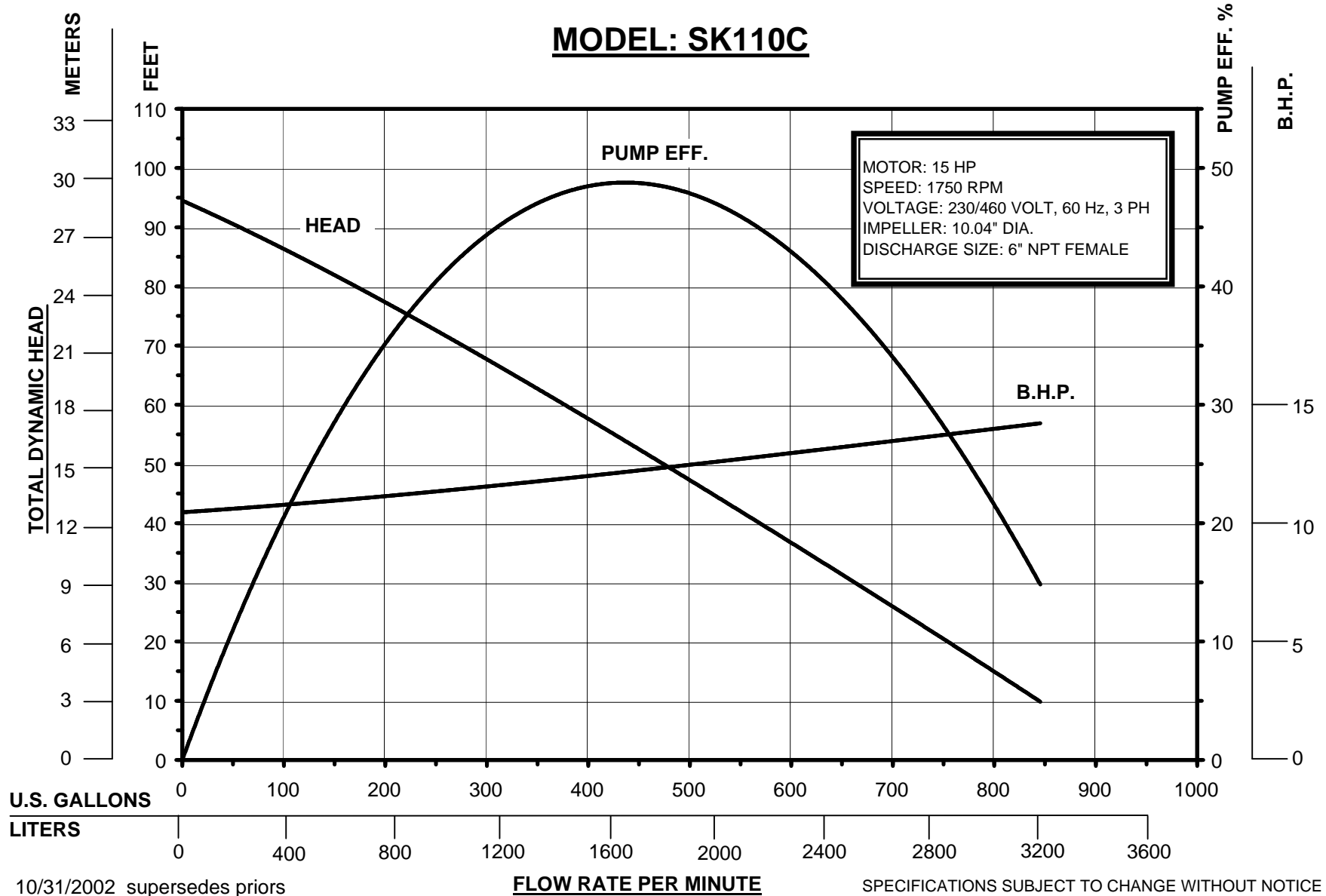



SK110 DIMENSIONAL DRAWING

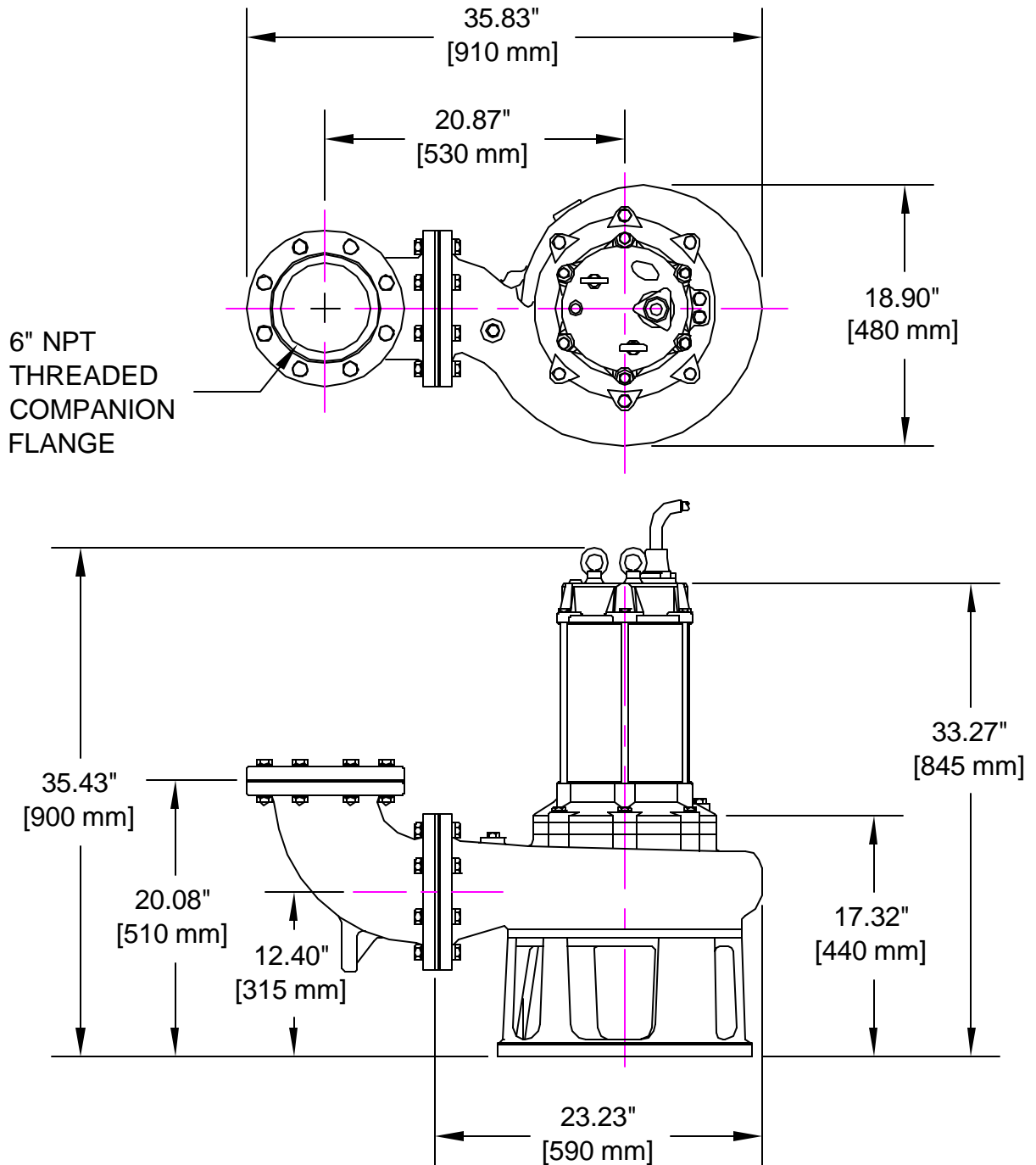

(DRAWING NOT TO SCALE)

BJM CORP. - 123 SPENCER PLAINS ROAD, OLD SAYBROOK, CT 06475 - PHONE: 860-399-5937 - FAX: 860-399-7784

REVISION 12/30/2002

Page 1 of 1

SPECIFICATIONS SUBJECT TO CHANGE WITHOUT NOTICE