



EL-FI® M10
SHAFT POWER MONITOR
INSTRUCTION MANUAL
 Motor shaft output power measurement

1 INSIDE THE BOX ...

This instruction manual describes the installation and commissioning of the M10 load monitor. The M10 supervises induction motor driven equipment and provides alarms when abnormal conditions are detected. If the machines "normal" load level is exceeded, the internal relay change state and the alarm LED turns red. The output relay contact can be used for alarm indication and/or machine shut-down. The M10 is ideal for many different applications; e.g. as an electronic shear pin and as pump dry running protection, for motors up to 50A. The unit is intended for price sensitive applications that only demand non-complex protection against under- or overload. For more advanced load monitoring the EL-FI M20 must be used.

- Check the delivery. Your shipment should contain the M10 load monitor, a current transformer and this instruction manual.
- Check carefully that the ordered equipment complies with the motors input voltage and that the current transformer rating is as stated on the delivery packaging.
- Check that the contents have not been damaged in shipping.

Note!

If in doubt contact your supplier before starting to install or commissioning the product.

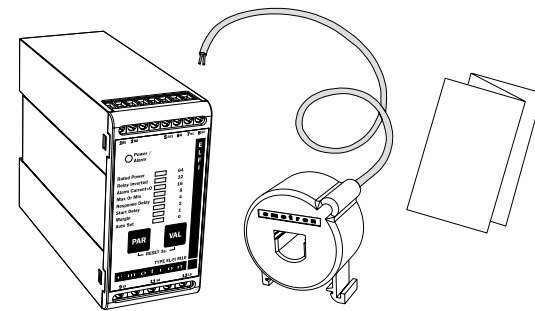

2 SAFETY

- Study this manual thoroughly before installing and using the monitor.
- The monitor must be installed by qualified personal.
- Always disconnect supply circuits prior to installing.
- The installation must comply with standard and local regulations.
- Pay special attention to this SAFETY section and the parts marked "CAUTION!" in sections 4 and 6.
- Should questions or uncertainties arise, please contact your local sales outlet or see chapter 9, SERVICE.

Note!

Removing or breaking the seal on the housing will invalidate the warranty.

3 WIRING

This wiring example shows how the M10 can be used to control the starting and stopping circuit of the motor. Other wiring configurations are possible.

1. The current transformer CTMxxx must be placed in the same phase that is connected to terminal 9, phase L1.
2. For single-phase connection see fig. 2.

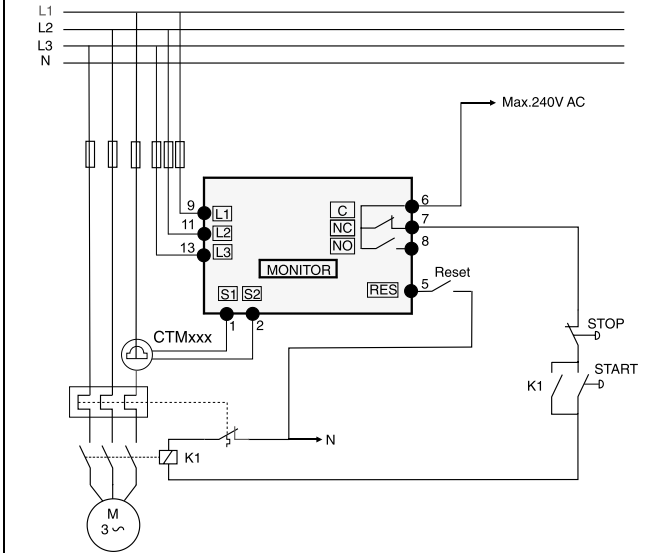

Fig 1. Standard wiring 3-phase motors.

Note!

If the START/STOP is connected according to fig. 1, it is recommended that terminals 6 and 7 be by-passed during settings. After the settings are completed the by-pass must be taken out.

3 Continue

ALTERNATIVE EXAMPLE FOR SINGLE-PHASE CONNECTION

This wiring example shows the alternative connection to be made with regard to a single-phase connection. Refer to fig. 1 for the remaining wiring.

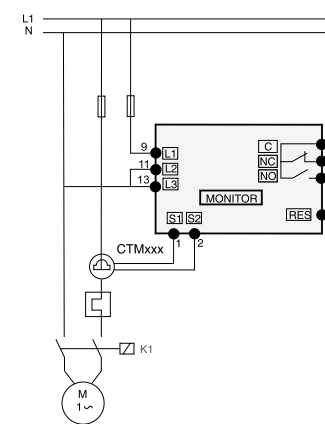

Fig 2. Single-phase wiring example.

LATCHED OR UN-LATCHED ALARM

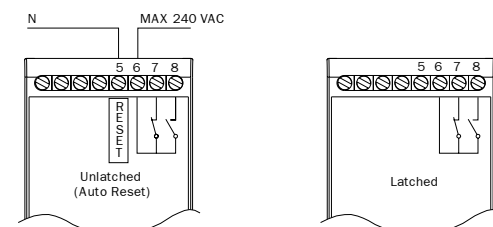

Fig 3. Wiring example for latched or un-latched alarm.

4 SELECTION CURRENT TRANSFORMER

FOR MOTORS UP TO 50 A

1. Check the rated motor current on the motor plate.
2. Compare this value with the Rated Motor Current in table 1.
3. From table 1, select the current transformer and the appropriate numbers of windings.

RATED MOTOR CURRENT (A)	CTM010	CTM025	CTM050
0.40 - 1.00	10		
1.01 - 2.00	5		
2.01 - 3.0	3		
3.1 - 5.0	2		
5.1 - 10.0	1		
10.1 - 12.5		2	
12.6 - 25		1	
26 - 50A			1

Table 1. Current transformer and number of primary windings.

Example

- Rated motor current = 12 A.
- Select 10.1 - 12.5 from the first colon in table 1 and choose CTM 025 with two (2) primary windings.

Note!

Max length of CTM cable is 1 m (39.37 in). For motors with rated current over 50 A contact your supplier.

CAUTION!

Terminals 1 and 2 (S1, S2) carry live voltage.

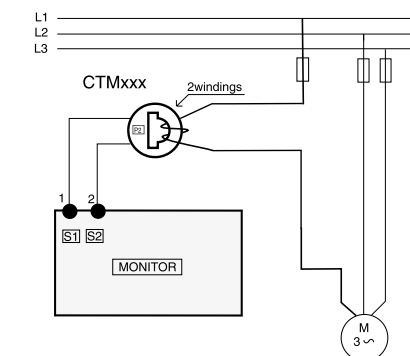

Fig 4. Example: CTM 025 with 2 windings for an 12 A motor.

Note!

Normally the appropriate Current Transformer (CTM xxx) will have been ordered and shipped with the M10, check that this is the case; contact the supplier if in doubt.

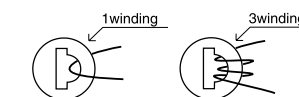

Fig 5. Example 1 and 3 windings.

Note!

The transformer connection and orientation are not polarity sensitive.

5 OPERATION

LED

- A constant green LED indicates a parameter type.
- A flashing green LED indicates a value.

Under normal system operation, the eight LED's are all off (see table 2). Any LED's illuminated will be automatically switched off 30 seconds after the last key press.

AUTO SET

The alarm load level is automatically set by the AutoSet function, see section 6.

Current input

Terminal 1 and 2. Current Transformer; CTM 010, 025 or 050 (Max 50 A motor).

Power/Alarm

The Power/Alarm LED indicates green at "power on" and at normal load. Red at alarm.

PAR

Parameter change (LED light constant green) - pressing PAR key when parameter is displayed proceeds to next parameter.

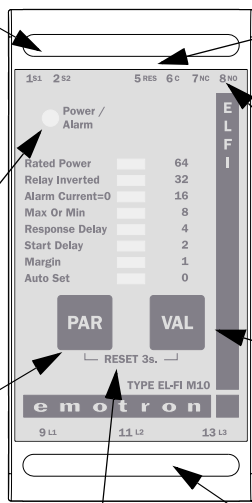

Reset input

Terminal 5 and 6 are used for external reset and selection of latched/unlatched alarm.

Relay output

Terminal 6, 7 and 8 output relay.

VAL

Value setting - Pressing VAL key when green LED is flashing increases value. A changed value is confirmed by pressing PAR.

Motor terminals

Terminal 9 (L1), 11 (L2) and 13 (L3) for supply and motor voltage input.

Reset
Reset a latched alarm by pressing both PAR and VAL at the same time in 3 s.

The value for a parameter, e.g. seconds, kW, HP or margin, can only be set as 0, 1, 2, 4, 8, 16, 32 or 64. Select closest value.

7 TECHNICAL DATA

Dimensions (WxHxD)	45x90x115 mm (1.77" x 3.54" x 4.53")
Mounting	35 mm DIN-rail 46277
Weight	175 g (5.65 oz)
Supply voltage	1x100-240 (± 10 %) 3x100-600 (± 10 %) 3x600-690 (± 10 %)
Frequency	50 or 60 Hz
Current input	Current transformers; CTM 010, 025 or 050 (Max 50 A motor)
Power consumption	Max 3 W
Start-up delay	1-64 s
Response delay	0.05-64 s
Relay output	5 A/240 VAC Resistive, 1.5 A/240 VAC Pilot duty/AC12
Fuse	Max 10 A
Terminal wire size	Use 75°C copper (CU) wire only. 0.2-4.0 mm ² single core (AWG12). 0.2-2.5 mm ² flexible core (AWG14), stripp length 8 mm (0.32")
Terminal tightening torque	0.56-0.79 Nm (5-7 lb-in)
Repeatability	± 2.5% FS, 24 H, @ +25 °C (+77°F)
Temperature tolerance	<0.1%/°C
External RESET on term. 5	Max 240 VAC or 48 VDC. High:>24 VAC/DC Low:< 1 VAC/DC
Operating temperature	-20 (4°F) – +50 °C (+122°F)
Storage temperate	-30 (22°F) – +80 °C (+176°F)
Protection class	IP20
Approved to	CE, cUL (UL and CSA up to 600 V)

6 PROGRAMMING

Set-up the monitor as below:

CAUTION!

Make sure that all safety measures have been taken before switching on the supply voltage and starting the motor/machine in order to avoid personal injury.

Set-up and first start

- Switch on the supply voltage - Power LED turns green.
- Press **PAR** once - "LED" AUTO SET turns green.
- Keep pressing **PAR** until the desired parameter is selected e.g. RATED POWER, see table 2 and 3.
- Press **VAL** - Factory set value or earlier set value flashes e.g. "64".
- Keep pressing **VAL** until desired value is displayed (0 - 64).
- Confirm chosen value by pressing **PAR**.
- Press **PAR** again and repeat steps B to F for all parameters except for AUTO SET. See table 2, 3 and fig. 6 for possible value setting for each of the eight parameters.
- Start and run motor/system at normal load conditions, also wait until the START DELAY has expired.

Hint!

Short-circuit the output relay during the set-up, this prevents the equipment to stopping unintentionally, see **Note!** in section "Wiring".

- Press **PAR** once - "LED" AUTO SET turns green.
- Press and hold **VAL** for 3 seconds, at normal machine load. The Auto Set load level is automatically set and the LED is switched off.
- Set/re-set e.g. start delay, response delay, margin etc. if necessary (see table 2, 3 and fig. 6).

Dismantling and disposal

The housing is made of recyclable plastic, PC/ABS and the circuit board contain small amount of tin and lead. When disposing, the parts must be handled and recycled in accordance with local regulations.

EU (European Union) specifications

EMC EN 50081-1, EN 50081-2,
EN 50082-1, EN 61000-6-2

Electrical safety IEC 947-5-1
Rated insulated voltage 690 V
Rated impulse withstand voltage 4000V
Pollution degree 2

Terminals 5, 6, 7 and 8 are basic insulated from the line.

US specifications

FCC (Federal Communications Commission)

This equipment has been tested and found to comply with the limits for a class A digital device pursuant to the Part 15 of the FCC Rules. These limits are designed to provide reasonable protection against harmful interference when the equipment is operated in a commercial environment. This equipment generates, uses and can radiate radio frequency energy and, if not installed and used in accordance with the instruction manual, may cause harmful interference, in which case, the user will be required to correct the interference at their own expense.

Canada specifications

DOC (Department of communications)

This digital apparatus does not exceed the Class A limits for radio noise emissions from digital apparatus as set out in the Canadian interference-Causing Equipment Regulations. Le présent appareil numérique n'émet pas de bruits radio-électriques dépassant les limites applicables aux appareils numériques de la Classe A prestite dans le Régelement sur le brouillage radioélectrique édicté du Canada.

Example: Conveyor with overload protection

Conveyor with overload protection, motor 11 kW (fig. 6).

- Check output power on motor plate and see table 3 (11 kW = Rated Motor Power 6.1- 12) - setting 8.
- Switch on the supply voltage - Power LED green.
- Press **PAR** once - "LED" AUTO SET turns green.
- Keep pressing **PAR** until RATED POWER is selected.
- Press **VAL** - Value "64" flashes (factory setting).
- Set recommended value according to table 3. Keep pressing **VAL** until chosen value (8) flashes.
- Confirm chosen value by pressing **PAR**.
- Press **PAR** again and select MAX.
- Press **VAL**. Chose the factory setting MAX - Overload Protection - "1".
- Confirm chosen value (1) by pressing **PAR**.
- Press **PAR** again and select RELAY INVERTED.
- Press **VAL**. Chose the factory setting "no" = "0".
- Confirm chosen value (0) by pressing **PAR**.

The above parameters are necessary to set for safe functioning. Note that "Rated power" for the motor must be set before Auto Set.

Hint!

Change the load on the machine to find out if appropriate load limit margin is set correctly. You can also reduce the margin by one or more steps to find out at what level the machine will trip. See fig. 6. Set/reset e.g start delay, response delay, trip margin etc. if necessary (see table 2).

8 PARAMETER LIST

Parameter	Factory setting	Actual setting	Alt. setting
RATED POWER	64		
RELAY INVERTED	0		
ALARM CURRENT = 0	0		
MAX OR MIN	1		
RESPONSE DELAY	2		
START DELAY	2		
MARGIN	8		

TERMINALS

Terminal	Label	Function
1	S1	Current transformer input for CTM 010, CTM 025 or CTM 050 ¹
2	S2	Current transformer input ¹
3		
4		
5	RES	Reset input. Latched or unlatched alarm is selected via this input. Connect to + at DC.
6	C	Alarm relay common and also reset common.
7	NC	Alarm relay normally closed
8	NO	Alarm relay normally open
9	L1	Motor voltage phase L1
10		
11	L2	Motor voltage phase L2 (N for single phase motors) ²
12		
13	L3	Motor voltage phase L3 (N for single phase motors) ²

¹ Note! Terminals 1 and 2 (S1, S2) carry line voltage.

² N must be connected to terminal 11 and 13 (single phase).

More Hints!

- If the alarm level is difficult to set - simply perform an Auto Set when the motor is stopped. Then start the machine, run at normal load and perform an Auto Set again.
- If a wrong value is unintentionally set - simply set a new value. If the value is not confirmed by pressing PAR, the new value is not accepted (time out after 30 seconds).

Parameter	Value	Factory setting	Note
RATED POWER	0 1 2 4 8 16 32 64	64	See table 3
RELAY INVERTED	0 (no) 1 (yes)	0	0 = Relay activated at alarm
ALARM CURRENT = 0	0 (no) 1 (yes)	0	Alarm at no motor current
MAX OR MIN	0 (MIN) 1 (MAX)	1	0 = under load 1 = overload alarm
RESPONSE DELAY	0 1 2 4 8 16 32 64	2	Response delay in seconds (0=50 ms)
START DELAY	0 1 2 4 8 16 32 64	2	Start delay in seconds
MARGIN (% of rated power)	0 1 2 4 8 16 32 64	8	Load change for alarm sensitivity, fig. 6
AUTO SET	AutoSet load level is automatically set if VAL key is pressed for 3 seconds.		VAL key must be pressed when LED parameter AUTO SET is light. LED bar is switched off when AutoSet level is set.

Table 2. Parameters and values.

Setting	Rated motor power in kW or HP
0	0 - 0.5
1	0.51 - 1.5
2	1.51 - 2.5
3	2.51 - 6
8	6.1 - 12
16	12.1 - 24
32	24.1 - 48
64	48.1 - 75

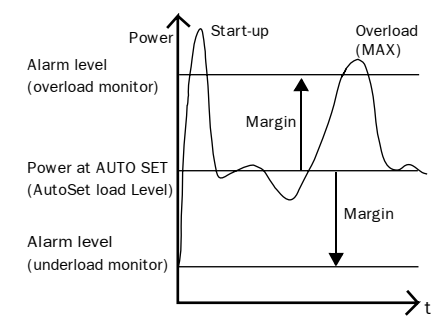

Table 3. Setting of rated motor power. Fig 6. Alarm level and margin.

9 SERVICE

This manual is valid for the following model:
EL-FI M10

Document number: 01-2550-01
Document version: r1a
Date of release: 2002-02-08

Emotron AB reserves the right to alter product specifications without prior notification. No part of this document may be reproduced without permission from Emotron AB.

For more information contact your local sales outlet or one of the Emotron companies below or visit us at: www.emotron.com

Emotron AB, Headquater, **Sweden**
Mörsaregatan 12, Box 222 25
SE-250 24 Helsingborg, Sweden
Tel. +46 42 169900
Fax +46 42 169949

Emotron Antriebssysteme GmbH, **Germany**
Tel. +49 3943 92050
Fax +49 3943 92055

Emotron B.V., The **Netherlands & Belgium**
Tel. +31 497 389222
Fax +31 497 386275

Emotron Drives (UK) Ltd, **Great Britain**
Tel. +44 1270 879 440
Fax +44 1270 886 119

Emotron El-Fi SA, **Spain**
Tel. +34 93 209 14 99
Fax +34 93 209 12 45

Emotron Inc., **USA**
Tel. +1 (419) 841-7774
Fax +1 (419) 843-5816

K.K. El-Fi, **Japan**
Tel. +81 42 528 88 20
Fax +81 42 528 88 21