

**RUNS DRY
FOR HOURS.**

**GUARANTEED
FOR YEARS.**

THE NEW DB SERIES

**SUPREME EFFICIENCY,
RELIABILITY AND
PERFORMANCE.**

Introducing the DB Series magnetic drive pump—the new standard for high hydraulic efficiency and corrosive fluid handling.

With design-aided magnetic flux and computational fluid dynamics technology, the DB Series packs all the high-pressure, fluid-handling punch you'd expect from a Finish Thompson pump.

AND THEN SOME.

Borne from a painstaking, extensive R&D effort, the efficiency of the DB Series lowers energy consumption and operating costs over the long life cycle of the pump.

Constructed from Polypropylene or PVDF, the DB Series operates durably in the most corrosive of environments. It can even run dry without damage. This rock solid embodiment of technological advancement is superior in precision, performance and reliability to other pumps on the market.

That's why we're offering the industry's best five-year warranty.

And why everyone else will undoubtedly be headed back to the drawing board.

1. Easy Set Outer Drive

Measurement-free outer drive ensures optimum magnet alignment and easy motor installation. Allows horizontal and vertical operation when used with IEC motors.

2. Multiple Impeller Diameters

Allows hydraulic requirements to be precisely met. Two-piece impeller design allows impeller to be changed without having to replace inner drive.

3. Multiple Connections

NPT or BSP threads, raised face adjustable flanges or union.

4. Run Dry System

The DB can run dry without damage when equipped with a chemical grade carbon bushing in optimum operating conditions. This helps protect the pump from operator errors and system upsets.

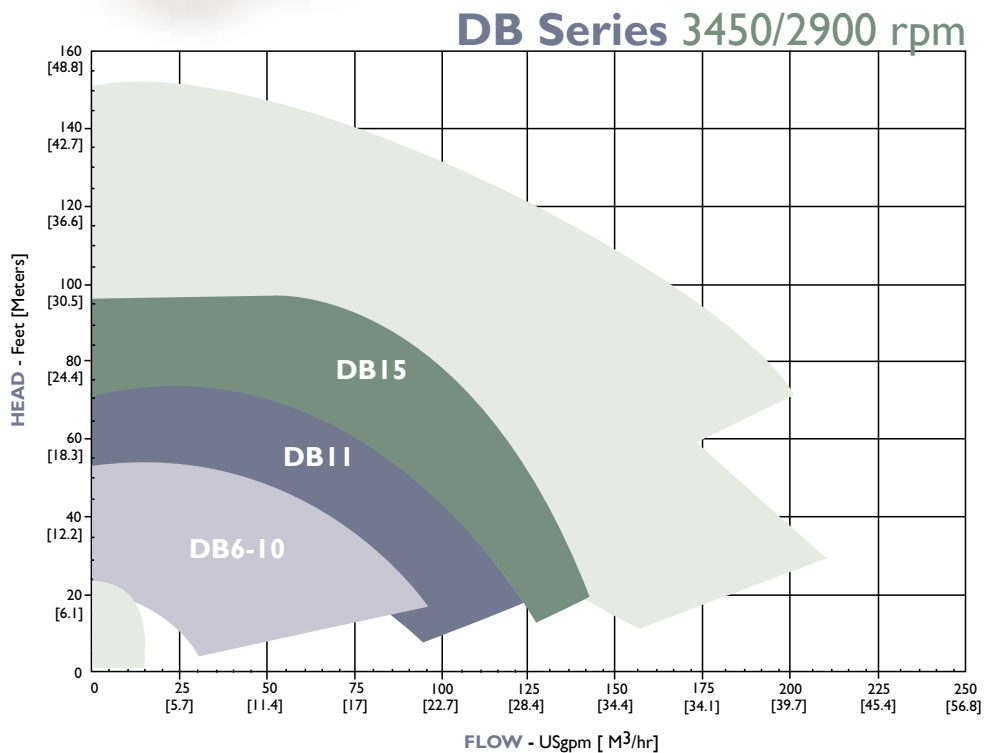
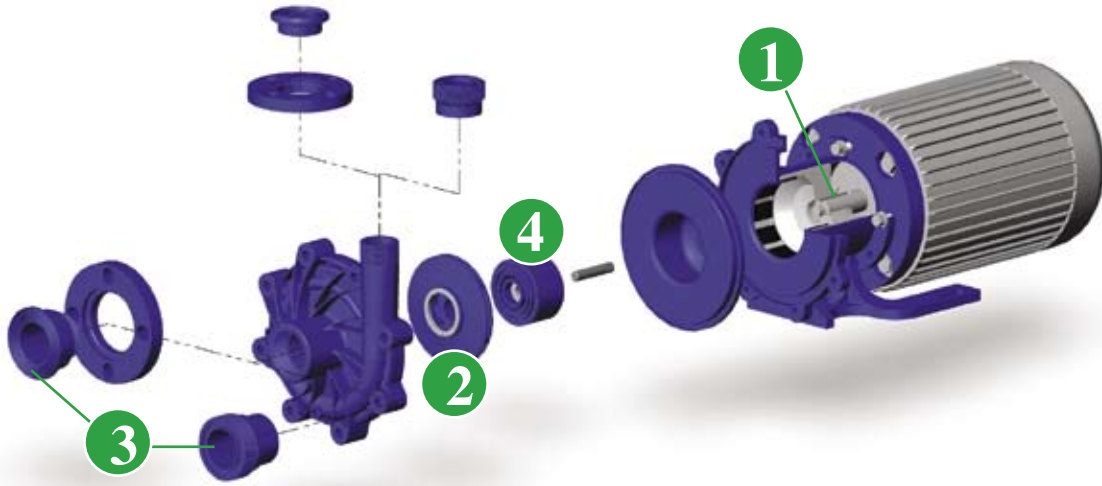

*Light green areas represent the KC Series, shown in 3450 rpm only. For information on KC Series pumps, visit our website.

FEATURES

- + Close-coupled design
- + Polypropylene or PVDF construction
- + Replaceable shaft
- + ISO 1940 G2.5 balancing
- + Mounts to Nema and IEC motor frames
- + Mounts to motor without disassembly
- + Back pullout design
- + Five-year warranty
- + CE certified/ATEX available

CAPABILITIES

- + High operating efficiency—up to 70%
- + High working pressure—up to 90 psi
- + High specific gravity handling—over 1.8
- + Maximum viscosity: 150 cP
- + Maximum Temperature: Polypropylene—180° F (82° C); PVDF—220° F (104° C)

APPLICATIONS

- + Chemical manufacturing
- + Metal plating/working
- + Wastewater treatment
- + Electronics manufacturing
- + Fume scrubbing
- + Mining
- + Paper mills
- + Printing
- + Pharmaceutical processing
- + Agriculture
- + OEM equipment supply
- + General pump applications

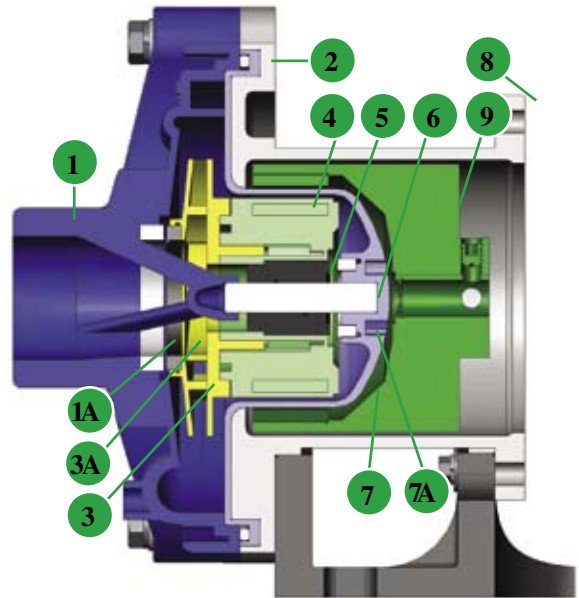

	Description	Polypropylene Models	PVDF Models
1	Impeller housing	Glass-fiber reinforced polypropylene	Carbon-fiber reinforced PVDF
1A	Impeller housing thrust ring options	High-purity alumina ceramic, silicon carbide	
2	O-ring options	FKM, EPDM, Simriz®, Kalrez®	
3	Impeller	Glass-fiber reinforced polypropylene	Carbon-fiber reinforced PVDF
3A	Impeller thrust washer options	Molybdenum disulfide filled PTFE, silicon carbide	
4	Inner drive	Neodymium iron boron magnets encapsulated in unfilled polypropylene	Neodymium iron boron magnets encapsulated in unfilled PVDF
5	Bushing options	Carbon, PTFE, high purity alumina ceramic, silicon carbide	
6	Shaft options	High-purity alumina ceramic, Hastelloy® C, silicon carbide	
7	Barrier	Glass-fiber reinforced polypropylene	Carbon-fiber reinforced PVDF
7A	Barrier thrust ring	High-purity alumina ceramic	
8	Motor adapter	Ductile iron	
9	Outer drive magnet	Nickel-plated neodymium iron boron magnets/steel	

Kalrez® is a registered trademark of DuPont Performance Elastomers
 Gylon® is a copyright of Garlock Sealing Technologies
 Simriz® Perfluoroelastomer is a registered trademark of the Simrit® division of Freudenberg-NOK
 Hastelloy® C is a registered trademark of Haynes International, Inc.



Engineered by computational fluid dynamics



*Looking for self-priming ability? Ask about our SP Series.
Pick the perfect pump. Visit our online pump selector at finishthompson.com.*



FINISH THOMPSON INC.
921 Greengarden Road • Erie, PA 16501-1591 U.S.A.
Ph 814-455-4478 • Fax 814-455-8518
Email fti@finishthompson.com • www.finishthompson.com

FT06-927B