

TM Series

D R U M M I X E R

Light to Medium Viscosity

The TM Series Drum Mixer is a 4-blade, turbine drum mixer ideal for mild corrosives, solvents, or flammables of light to medium viscosity.

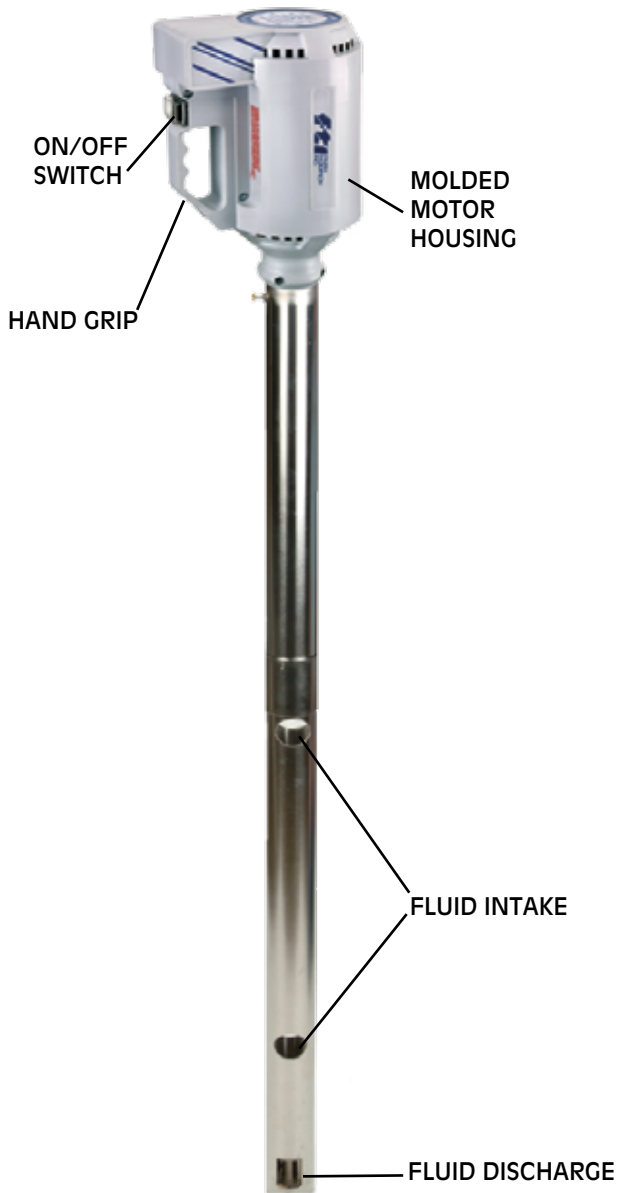

Features

- Sealed
- 4-blade turbine mixing and blending
- Non-aerating, non-vortexing circulation
- Loosens and suspends bottom settlements
- Handles dyes, paints, inks, stains
- Tube interchangeable with choice of motors
- Stainless steel and PTFE construction

Performance

- 14 gpm (53 L/min.) circulation
- Up to 1,000 cP
- Maximum 200°F (93°C)

- *Top-to-bottom mixing action allows rapid suspension of settled solids.*
- *Pulls lighter liquid from top and discharges under pressure out the bottom of the mixer tube.*



Tube Specifications



MODEL	TUBE					SEAL	SHAFT	INTERNALS
	MATERIAL	DIAMETER		LENGTH				
		in.	cm	in.	cm			
TMS	316SS	2	5.1 cm	40	102	Graphite Filled PTFE	316 SS	PTFE and 316SS

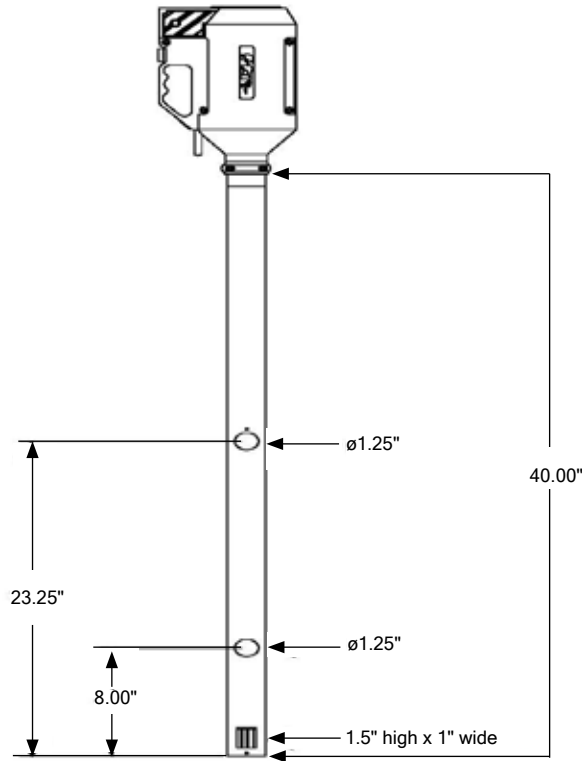

Motor Specifications



Electric motors are available in 110V or 220V, Single Phase, 50-60 Hz. All are equipped with 12 ft. (336 cm) cord, circuit breaker with manual reset, internal cooling fan, and built-in on/off switch. Motors are rated continuous duty.



Air motor (M6X) shown with ball valve and muffler.

MODEL	TYPE	CERTIFICATIONS	ELECTRICAL REQUIREMENTS	INPUT		RPM
				HP	W	
M6X	Air*	CE	80-100 psi@15-32 cfm	3/4	560	300-6,000
M7T	TEFC	CSA	110VAC/50-60 Hz	2/3	500	2850/3450
M7X	Exproof	CSA	110VAC/50-60 Hz	2/3	500	2850/3450
M8T	IP54	CE	220VAC/50-60 Hz	1	750	2850/3450

NOTE: When mixing flammables or combustibles, use explosion proof electric or non-electric (air) motors on stainless steel tubes with a static protection kit #A100961.

NOTE: Not ATEX approved.

*An air motor is a non-electrical device. This means the possibility of explosion from igniting flammables or combustibles is reduced.



FINISH THOMPSON INC.

921 Greengarden Road • Erie, PA 16501-1591 U.S.A.
Ph 814-455-4478 • Fax 814-455-8518
Email fti@finishthompson.com • www.finishthompson.com

Toll Free USA & Canada 1-800-934-9384
Literature I. D. No. - FT95-560G, 3/04/11

