



FINISH THOMPSON INC.

VKC 5.5,6,6H, 7,8,10 SERIES Sealless Non-Metallic Vertical Pumps Installation and Maintenance Instructions

Pat.No. 5,708,313

ASSEMBLY

PUMPS WITH MOTORS

1. No assembly required. Simply unpack the pump and motor and examine for any signs of shipping damage. If damage is detected, save the packaging and notify the carrier immediately.
2. Ensure that lock rings are securely snapped in place and did not loosen during shipment.
3. To install the pump into the system, follow the installation instructions provided.

PUMPS WITHOUT MOTORS (56C FRAME)

1. Unpack the pump and any supplied accessories and examine for damage. If damage is detected, save the packaging and notify the carrier immediately.
2. Create a hole if required for discharge piping in the optional mounting plate (item 10) at desired location.
3. Prepare to install the motor on the pump. Carefully place the motor on the fan cover on a suitable, level work surface.
4. Install key into motor shaft key slot. Align the keyway slot on the coupling half and slide the coupling half on. Set coupling half with the motor shaft recessed 7/32" and tighten both setscrews with an 1/8" Allen wrench to 70 in-lbs.
5. Insert the coupling insert (item 27) into the coupling half on the motor. Carefully slide motor adapter (item 9) end of the pump assembly over the motor shaft until both coupling halves are completely seated in the coupling insert. Make sure rabbet (step) on the motor is firmly seated into motor adapter.

⚠ CAUTION: Pump assembly may be top heavy.

6. Rotate the pump and mounting plate to the desired orientation. Align the holes in the mounting plate and the motor adapter with the holes in the motor face. Secure the mounting plate and motor adapter to the motor using (4) washers, lock washers and 3/8" bolts (items 6,7,8) from the hardware package. [If metric frame use (4) 3/8" hex nuts (item 31)].
7. Ensure that lock rings are securely snapped in place and did not loosen during shipment.
8. Install the pump into the system according to the installation instructions provided.

PUMPS WITHOUT MOTORS (METRIC FRAME)

1. Unpack the pump and any supplied accessories and examine for damage. If damage is detected, save the packaging and notify the carrier immediately.
2. Create a hole if required for discharge piping in the optional mounting plate (item 10) at desired location.
3. Prepare to install the motor on the pump. Carefully place the motor on the fan cover on a suitable, level work surface.

4. For 63 & 71 frame motors, install the motor shaft key into the slot, align the keyway slot in the coupling half, and slide the coupling half onto the motor shaft. Set coupling half with motor shaft recessed 11.1 mm. Tighten both setscrews with a 1/8" Allen wrench to 7.9 N-m.

For 80 frame motors, set the coupling half so that it is flush with the end of the motor shaft and tighten both setscrews with a 1/8" Allen wrench to 7.9 N-m.

⚠ CAUTION: Improper orientation of the metric motor adapter can cause premature coupling failure or cause the pump shaft to bottom out on the motor shaft before the pump is properly installed onto the metric motor adapter.

5. Install the metric motor adapter flange (item 2) on the motor with (4) socket head cap screws (item 5). For 71 frame motors use washers (items 3 & 4). One side of the adapter fits 63/80 frame motors (side B) and the other side is for 71 frame motors (Side A). On 71 frame motors, the hex shaped recess in the metric motor adapter will face toward the motor face. For 63/80 frame metric motors, the hex shaped recess in the metric motor adapter will face away from the motor face. The metric motor adapter must be oriented so that the adapter seats onto the motor rabbet.
6. Place the coupling insert onto the coupling half on the motor shaft. Carefully slide the motor adapter end of the pump over the motor shaft making sure both coupling halves are engaging completely in the insert. Verify that the motor adapter (item 9) is completely seated on the metric motor adapter flange (item 2).
7. Rotate the pump discharge and the mounting plate to the desired orientation. Align the bolt holes on the mounting plate with the motor adapter (item 9) and the metric motor adapter flange (item 2). Secure with the hardware provided.
8. Make sure that the locking rings are securely snapped in place and did not loosen during shipping or the assembly process.
9. Install the pump into the system according to the installation instructions provided.

INSTALLATION

The VKC Series is a versatile pump designed to be operated in a variety of mounting configurations. The pump can be mounted either inside or outside of a tank or sump. See Figure 1.

NOTE: Drawings for illustration only. Pumps need to be properly supported when installed.

MOUNTING

A mounting plate is recommended for in tank installations. Use a hole saw to cut holes in desired location for piping if required.

Support and securely fasten the mounting plate on all four sides if possible or on two sides if mounted in a corner. Drill holes in the mounting plate at the desired location for bolting to the tank.

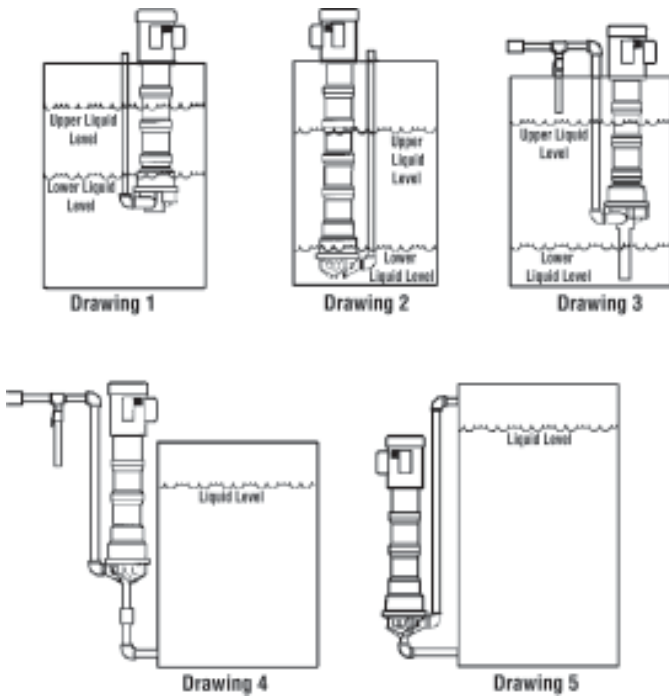

Figure 1

Drawing 1 shows drawing of pump mounted inside tank with suction off the bottom of the tank and level fluctuating from near top of pump column to close to the bottom of the pump.

Drawing 2 shows drawing of pump suction near tank bottom and level fluctuating between the top and bottom of the tank.

Drawing 3 shows drawing of pump with suction extension and the level fluctuating between startup level and low level.

Drawing 4 shows drawing of pump mounted outside the tank.

Drawing 5 shows drawing of pump mounted outside the tank with the motor below the liquid level.

A drip cover may be installed on top of the motor if desired.

Mount pump in desired configuration. Securely fasten mounting plate if used. Motor feet may also be used for mounting.

PIPING

1. Support piping near the pump to eliminate any strain on the pump casings. Do not use suction or discharge piping to support the pump.
2. Do not overtighten the piping on the discharge on initial installation (i.e., down to the collar on NPT housings or the o-ring on BSP housings). Damage to the discharge can occur. The o-ring on the BSP housing is only used when the plastic threads are loose.
3. Do not place the pump suction directly on the bottom of the tank. Keep the pump suction at least one pipe diameter off the bottom.
4. A suction extension tube of up to nine feet in length can be added.
5. To minimize head loss from friction:
 - a. Increase pipe size by 1 diameter.
 - b. Use minimal number of pipe bends.
6. If a check valve is installed in the discharge piping, an air bleed must be installed in the discharge line to prevent air lock. This allows air trapped in the pump internals to be removed on initial start-up. See drawings 3 and 4 in Figure 1.
7. Maintain a flooded suction. Use a foot valve if necessary.

8. Ensure that the piping does not leak and suction is not prone to clogging. Use a strainer if necessary on the suction.
9. If flexible hose is preferred, use reinforced hose rated for the proper temperature and pressure. This helps avoid collapse or kinks.
10. Install valves a minimum of 10 pipe diameters from the pump.
 - ▲ **CAUTION:** To stop the pump if prime is lost, use one of the following: (1) pressure switch on the discharge or (2) motor minder to monitor motor current.

ELECTRICAL

1. Install the motor according to NEC requirements and local electrical codes. Motor should have an overload protection circuit.
2. Wire the motor for clockwise rotation when facing the fan end of the motor.
3. To verify the correct motor rotation:
 - a. Install the pump into the system
 - b. Fully open the suction and discharge valves
 - c. Allow fluid to run into the pump. Do not allow the pump to run dry (PTFE and ceramic bushings can't be run dry without causing damage to internal parts).
 - d. Jog the motor (allow it to run for only one to two seconds) and observe the rotation of the motor fan. Refer to the directional arrow by the electrical box if needed.

Note: A pump running backwards will pump but at a greatly reduced flow and pressure.

OPERATION

1. Completely open discharge valve. On pumps equipped with a discharge check valve, open air bleed valve on initial start-up.
2. Start the pump and check liquid flow. If there is no flow, see the Troubleshooting section.
3. Adjust the flow rate and pressure by regulating the discharge valve.

MAINTENANCE

WET END INSPECTION / REPLACEMENT

1. Disconnect the power. Unwire the motor (mark the wires for correct rotation upon reassembly). Close the suction and discharge valves, and remove the pump from the installation. Remove any discharge piping that will hinder the removal of the housing.
2. Place the pump on a clean work bench and secure the motor or mounting plate. Gently tap the locking ring (item 11) towards the motor until it is loose (the locking ring connects the column housing adapter (item 15) to the next section). Using a strap wrench, unthread the column housing section turning it counterclockwise. Grasping the discharge and pump head, pull it straight off of the pump and place it on the bench with the suction pointing straight up.
3. Make an alignment mark on the side of the impeller housing (item 21) and the column housing adapter (item 15) to aid in alignment during the reassembly process. Remove the six impeller housing mounting screws (items 22). Remove the impeller housing (item 21) and o-ring (item 16). Grasp the impeller and remove it from the column housing adapter (item 15).

▲ **CAUTION:** Keep the drive magnet assembly (item 14) and impeller drive (item 18) away from metal chips or particles.

NOTE: Keep the impeller housing o-ring (item 16) with the impeller housing to avoid mix up during reassembly.

EXAMINATION

1. Check the impeller drive bushing (item 17), thrust ring (item 20), ceramic thrust ring and shaft for cracks, chips, scoring or excess wear. See figure 2. Replace as required.

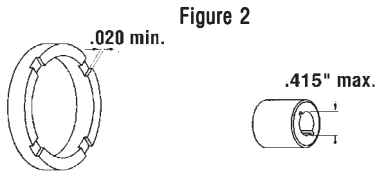

2. Check for loose magnets on the drive assembly or rubbed areas on the impeller or column housing adapter assemblies. Contact your distributor or FTI Technical Service if a problem is found.

BUSHING REPLACEMENT

1. To remove the bushing, insert 1/16" pin punch into balance hole (inner circle of 4 holes) of impeller assembly (items 17,18,19,20). Gently tap the bushing out of the back of the impeller assembly. The punch may need to be moved to a different hole if the bushing is difficult to remove.
2. To replace the bushing, clean the impeller bore. Insert the new bushing into the back of the impeller assembly by aligning the bushing with the impeller bore. Press gently until the bushing bottoms out (use a block of wood and mallet if necessary).

MOTOR REPLACEMENT

Remove the four bolts and washers (items 6, 7, and 8) securing the motor adapter (item 9) to the motor. Carefully pull the pump away from the motor face. Loosen the two setscrews on the coupling half (located on the motor shaft). Remove the coupling half. Install motor shaft coupling half onto a new motor following the assembly instructions on page one for 56C or metric frame pumps. Make sure the coupling insert meshes. Install pump onto the new motor.

DRIVE MAGNET ASSEMBLY, SHAFT BEARING OR COLUMN SECTION REPLACEMENT

1. The drive magnet assembly (item 14) is locked in place with a left hand threaded 5/8-18 jam nut (item 32). Loctite Thread Locker #262 is used to secure the jam nut and may require some heat to loosen the bond for removal. Secure the pump shaft using the flats located on the motor side of the drive magnet assembly, and remove the jam nut. Unthread the drive magnet assembly (left hand thread) from the shaft.
2. Loosen the two setscrews on the shaft bearing (item 28). Gently tap the next locking ring (item 11) toward the motor until it is loose. Using a strap wrench, unthread and remove the column extension (item 30). Repeat step two for each section removed.
3. When you are down to the motor adapter section (item 9), remove the four bolts holding the adapter (and mounting plate if you have one) to the motor. Mark the flange on the motor adapter / mounting plate and the motor face for correct orientation when reassembling. Remove the mounting plate, and pull the motor adapter from the motor face.

4. 12" models will have two bearings in the motor adapter section. If further disassembly is necessary, loosen the two setscrews on the pump side bearing, and gently press the shaft and the second bearing toward the motor end until it loosens. If the bearing or the shaft need replacement, loosen the setscrews and remove the pump shaft coupling half. Loosen the setscrews on the bearing and slide it off the shaft. On models 18" or longer, just loosen the setscrews on the pump shaft coupling half and remove it.
5. Spin all of the bearings and visually inspect for binding or corrosion. To replace, remove the four screws and washers (items 29 and 33). Gently tap the bearings toward the pump end of each section until they are loose.
6. Inspect the drive magnet assembly, each column section, all of the bearings, shaft, and o-rings for wear or damage. Replace as needed.

REASSEMBLY

1. If the shaft, or the first bearing on a 12" model was replaced, you will need to slide the new bearing onto the shaft with the setscrew side facing away from the motor. Adjust the bearing to the correct setting in Figure 3, and tighten both setscrews.



Figure 3

Pump	Motor Frame	Dim. "A"
VKC6/8/10	56C	0.95"
VKC6/8/10	80	2.41"
VKC6/8/10	71	2.19"
VKC6/8/10	63	2.40"

2. Install the key into the keyway cut in the motor end of the pump shaft (item 13). Align the coupling half keyway slot and install the coupling half with the splines pointing toward the motor end. For 56C frame, set the coupling with the shaft end recessed .218". Tighten the setscrews. For 63 and 71 frames, set the coupling with the shaft end recessed .437" and tighten the setscrews. For 80 frame, set the coupling with the shaft recessed .250 and tighten the setscrews.
3. For 12" models - from the motor side, insert the threaded end of the shaft up through the center of the motor adapter (item 9). Press the bearing into the machined recess making sure to use the outer bearing race as the point of contact.
For models 18" or longer, insert the threaded end of the pump shaft up through the bearing already in place in the pump end of the motor adapter. Leave the bearing setscrews loose.
4. For metric frame pumps, install the metric motor adapter flange (item 2) per instructions in step 4 of "Pumps Without Motors (Metric Frame) from page 1.

VKC SUMP

Figure 6

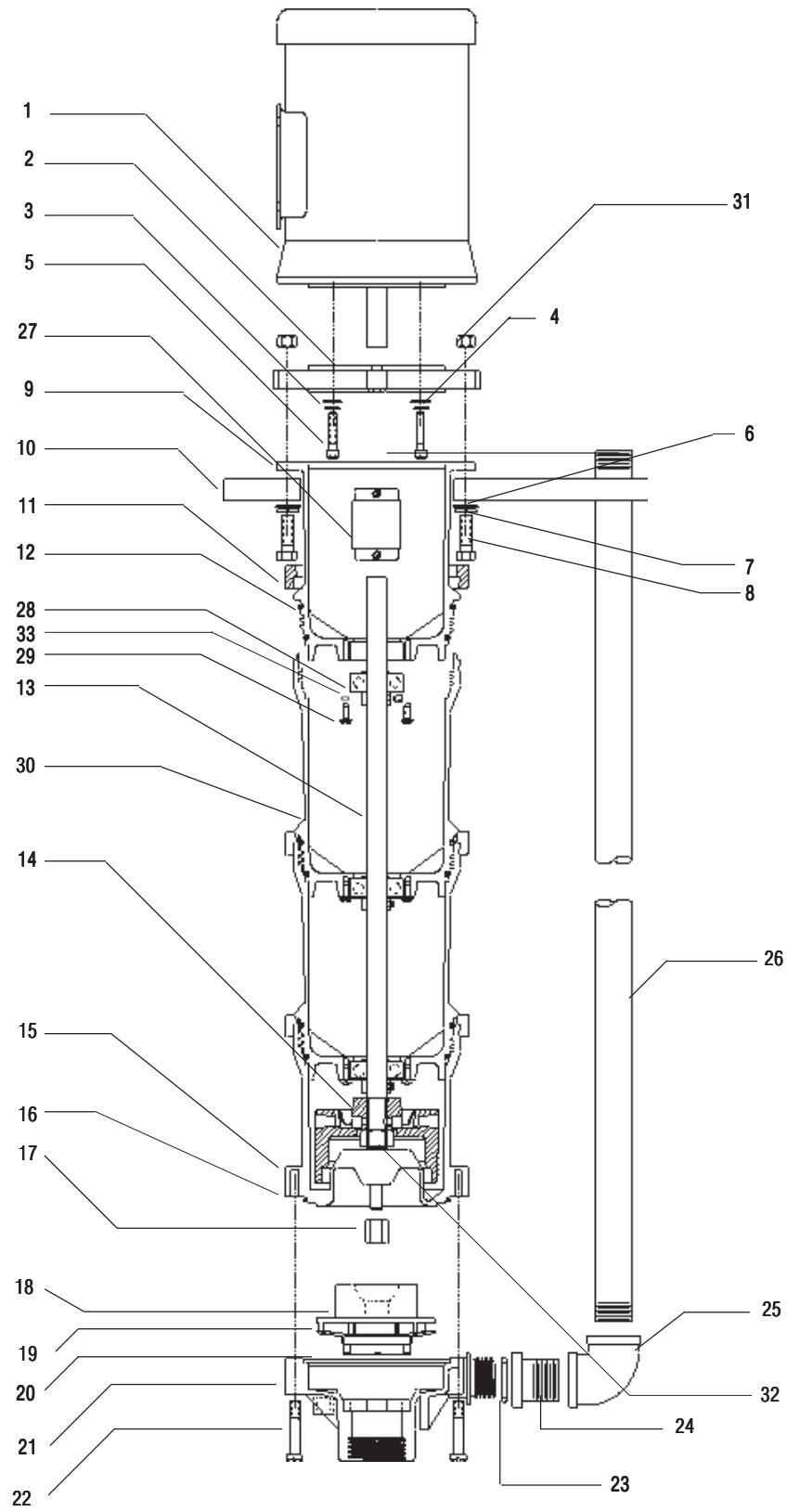

VKC 5.5,6,6H,7,8,10 PARTS LIST

Item	Qty	Description	Pump	PP Part No.	PVDF Part No.
1	1	Motor	All	Contact Distributor	Contact Distributor
2	1	Metric Motor Adapter Flange, 63/71/80 frame	All Metric	M101947	M101947
3	4	1/4" Flat Washer S.S.	All Metric	J100113	J100113
4	4	1/4" Lockwasher S.S.	All Metric	J100672	J100672
5	4	Socket Head Cap Screw 63 Frame M5 x 40 mm	All	J103226	J103226
		71/80 Frame M6 x 35 mm	All	J103228	J103228
6	4	3/8" Flat Washer S.S.	All	J100128	J100128
7	4	3/8" Lockwasher S.S.	All	J100115	J100115
8	4	3/8 -16 Hex Hd. Cap Screw 56C w/ Mtg Plate (3/8-16 x 1 3/4"lg)	All	J103161	J103161
		56C w/o Mtg Plate (3/8-16 x 1" lg)	All	J100114	J100114
		63/71/80 Fr. w/ Mtg Plate (3/8-16 x 2 1/4" lg)	All	J103227	J103227
		63/71/80 Fr w/o Mtg Plate (3/8-16 x 1 1/2" lg)	All	J103207	J103207
9	1	Motor Adapter	All	M101981-1	M101981-2
9	1	Motor Adapter - 12" models	All	A103377-1	A103377-2
10	1	Mounting Plates 9 1/2" X 10 1/4" PVC Mounting Plate	VKC 5.5,6,6H	J103132-3	J103132-3
		CPVC Mounting Plate	VKC 5.5,6,6H	J103132-4	J103132-4
		PVC Mounting Plate	VKC 7,8,10	J103132-5	J103132-5
		CPVC Mounting Plate	VKC 7, 8,10	J103132-6	J103132-6
11		Locking Ring	All	M101984-1	M101984-2
12		Motor Adapter/Column O-Ring Viton	All	J103306	J103306
		EPDM		J103308	J103308
13	1	Drive Shaft			
		12" 56C Frame		M102119-9	M102119-9
		12" 63/80 Frame		M102119-19	M102119-19
		12" 71 Frame		M102119-10	M102119-10
		18" 56CFrame		M102119-1	M102119-1
		18" 63/80 Frame		M102119-20	M102119-20
		18" 71 Frame		M102119-5	M102119-5
		24" 56CFrame		M102119-2	M102119-2
		24" 63/80 Frame		M102119-21	M102119-21
		24" 71 Frame		M102119-6	M102119-6
		30" 56C Frame		M102119-3	M102119-3
		30" 63/80 Frame		M102119-22	M102119-22
		30" 71 Frame		M102119-7	M102119-7
		36" 56C Frame		M102119-4	M102119-4
		36" 63/80 Frame	All	M102119-23	M102119-23
		36" 71 Frame		M102119-8	M102119-8
		42" 56C Frame		M102119-11	M102119-11
		42" 68/80 Frame		M102119-24	M102119-24
		42" 71 Frame		M102119-15	M102119-15
		48" 56C Frame		M102119-12	M102119-12
		48" 68/80 Frame		M102119-25	M102119-25
		48" 71 Frame		M102119-16	M102119-16
		54" 56C Frame		M102119-13	M102119-13
		54" 63/80 Frame		M102119-26	M102119-26
54" 71 Frame		M102119-17	M102119-17		
60" 56C Frame		M102119-14	M102119-14		
60" 63/80 Frame		M102119-27	M102119-27		
60" 71 Frame		M102119-18	M102119-18		
14	1	Drive Magnet Assembly - 6 pole		A101989-17	A101989-17
		Drive Magnet Assembly - 8 pole	All	A101989-18	A101989-18
		Drive Magnet Assembly - 10 pole		A101989-19	A101989-19
		Drive Magnet Assembly - 12 pole		A101989-20	A101989-20
15	1	Column Housing Adapter	All	A102271-1	A102271-2
16	1	Impeller Housing O-Ring Viton	All	J102389	J102389
		EPDM		J102585	J102585
17	1	Impeller Bushing, Carbon		J102387	J102387
		Impeller Bushing, PTFE	All	J102790	J102790
		Impeller Bushing, Ceramic		J103617	J103617
18	1	Impeller Drive with Carbon Bushing (6 pole)	VKC 5.5,6,7	A102746-1	A102746-2
		Impeller Drive with Carbon Bushing (8 pole)	VKC 6H,8	A102746-4	A102746-5
		Impeller Drive with Carbon Bushing (10 pole)	VKC 10	A102746-7	A102746-8

Item	Qty	Description	Pump	PP Part No.	PVDF Part No.
18	1	Impeller Drive with Carbon Bushing (12 pole)	VKC 10	A102746-16	A102746-18
		Impeller Drive with PTFE Bushing (6 pole)	VKC 5.5,6,7	A102746-10	A102746-13
		Impeller Drive with PTFE Bushing (8 pole)	VKC 6H,8	A102746-11	A102746-14
	1	Impeller Drive with PTFE Bushing (10 pole)	VKC 10	A102746-12	A102746-15
		Impeller Drive with PTFE Bushing (12 pole)	VKC 10	A102746-17	A102746-19
		Impeller Drive with Ceramic Bushing (6 pole)	VKC 5.5,6,7	A102746-20	A102746-21
		Impeller Drive with Ceramic Bushing (8 pole)	VKC 6H,8	A102746-22	A102746-23
		Impeller Drive with Ceramic Bushing (10 pole)	VKC 10	A102746-24	A102746-25
		Impeller Drive with Ceramic Bushing (12 pole)	VKC 10	A102746-26	A102746-27
19	1	Impeller Head with Thrust Ring	VKC 5.5 (3.00")	A101983-10	A101983-11
		Impeller Head with Thrust Ring	VKC 6 (3.19")	A101983-1	A101983-4
		Impeller Head with Thrust Ring	VKC6H (3.88")	A101983-13	A101983-14
		Impeller Head with Thrust Ring	VKC7 (3.19")	A101983-15	A101983-16
		Impeller Head with Thrust Ring	VKC 8 (3.50")	A101983-2	A101983-5
		Impeller Head with Thrust Ring	VKC 10 (3.88")	A101983-3	A101983-6
20	1	PTFE Thrust Ring	VKC 5.5,6	J102388	J102388
		PTFE Thrust Ring	VKC 6H	J104045	J104045
		PTFE Thrust Ring	VKC7	J103893	J103893
		PTFE Thrust Ring	VKC 8,10	J101606	J101606
21	1	Impeller Housing with Thrust Ring (NPT)	VKC 5.5,6,6H	A101981-1	A101981-3
		Impeller Housing with Thrust Ring and Viton Discharge O-Ring (BSP)	VKC 5.5,6,6H	A101982-3	A101982-4
		Impeller Housing with Thrust Ring and EPDM Discharge O-ring (BSP)	VKC 5.5, 6,6H	A101982-7	A101982-8
		Impeller Housing with Thrust Ring (NPT)	VKC 7,8,10	A101981-7	A101981-9
		Impeller Housing with Thrust Ring and Viton Discharge O-ring. (BSP)	VKC 7,8,10	A101982-11	A101982-12
		Impeller Housing with Thrust Ring and EPDM Discharge O-ring (BSP)	VKC 7,8,10	A101982-15	A101982-16
22	6	Impeller Housing Mounting Screws (PVDF)	All	J103149	J103149
		Impeller Housing Mounting Screws (Titanium)		J103524	J103524
		Impeller Housing Mounting Screws (Hastelloy C)		J103535	J103535
23	1	Discharge O-ring Viton	VKC5.5,6,6H	J102390	J102390
		Discharge O-ring EPDM		J102712	J102712
		Discharge O-Ring Viton	VKC7, 8,10	J102391	J102391
		Discharge O-ring EPDM		J102713	J102713
24	1	Hex Reducer Bushing 1" x 3/4"	VKC 5.5,6,6H	J103158	J103153
		Hex Reducer Bushing 1 1/2" x 1"	VKC7, 8,10	J103160	J103159
25	1	90° Elbow x 1"	VKC 5.5,6,6H	J103167	J103168
		90° Elbow x 1 1/2"	VKC 7,8,10	J103165	J103166
26	1	Discharge Pipe	VKC 5.5,6,6H		
		12"		M101966-1	M101966-2
		18"		M101966-7	M101966-8
		24"		M101966-3	M101966-4
		30"		M101966-9	M101966-10
		36"		M101966-5	M101966-6
		42"		M101966-11	M101966-12
		48"		M101966-13	M101966-14
		54"		M101966-15	M101966-16
		60"		M101966-17	M101966-18
26	1	Discharge Pipe	VKC 7,8,10		
		12"		M101965-1	M101965-2
		18"		M101965-7	M101965-8
		24"		M101965-3	M101965-4
		30"		M101965-9	M101965-10
		36"		M101965-5	M101965-6
		42"		M101965-11	M101965-12
		48"		M101965-13	M101965-14
		54"		M101965-15	M101965-16
		60"		M101965-17	M101965-18
27	1	Coupling	All		
		56C Frame		A102485	A102485
		63 Frame		A102486	A102486
		71 Frame		A102487	A102487
		80 Frame	A102488	A102488	
28		Shaft Bearing (see General Notes for qty.)	All	J103157	J103157
29		Bearing Retaining Screw	All	J103175	J103175
30		Column Extension	All	M101982-1	M101982-2
31	4	3/8-16 Hex Nut for Metric	All	J100135	J100135
32	1	Jam Nut (left hand threads)	All	J103515	J103515
33	4	#10 Flat Washer SSTL		J103638	J103638

5. Install the coupling insert onto the pump shaft coupling half. Place motor on its fan cover on a flat clean area. Make sure the coupling splines mesh with the insert. Install the motor adapter and pump shaft onto the motor face. Verify the motor adapter seats completely onto the motor rabbet (or metric motor adapter flange on metric pumps). Install the mounting plate (if one is used) and align the marks on the motor, the motor adapter flange and the mounting plate for correct orientation. Install the four bolts and tighten to the motor face.
6. For 12" models, go to step 8. For models 18" or longer, rotate the pump shaft and press down to insure complete coupling engagement. While holding the shaft snugly down, tighten the bearing setscrews.
7. If column o-rings (item 12) were removed or need replacement, lubricate the o-rings with a compatible lubricant and install them in the o-ring grooves. If the bearing (item 28) was removed, press the new bearing (only making contact with the outer bearing race) into the recess with the extended race (setscrews) facing away from the motor. Install the four retaining screws and washers (items 29 and 33).
8. Lubricate the motor adapter o-rings (item 12) with a compatible lubricant. Place the locking ring (item 11) (with the smaller inside diameter side toward the motor) over the end of the column section and slide it toward the motor. Install the column extension (item 30) by aligning the threaded end of the shaft through the bearing and sliding it down to the top of the motor adapter. Secure the motor and mounting plate to the table. Using a strap wrench, thread the column extension onto the motor adapter. Tighten the section until there is no gap between the sections and the flats are parallel. Tighten the two bearing setscrews into the pump shaft. Pull the locking ring (item 11) toward the pump end until it snaps into place locking the two sections together.
9. Repeat step eight until all column extensions are installed. If the pump is a 24" model or longer, you may need a second strap wrench to hold the previous section in place while tightening the new one.

NOTE: It may be possible to slightly overtighten these sections. Simply back off slowly until the flats are aligned and the lock ring snaps into place.
10. Install the left hand threaded drive magnet assembly (item 14) onto the drive shaft (item 13) until it is set at 4.00 +/- .015 as measured from the top of the motor adapter/column extension to the top of the drive magnet assembly. See Figure 4. Apply a small amount of Loctite Thread Locker #262 to the inside threads on the 5/8-18 left hand jam nut (item 32) and the outside threads on the drive shaft. Thread the jam nut on until it makes contact with the drive. Hold the drive magnet assembly still and tighten it to 50 ft. pounds. Recheck the drive magnet setting after the jam nut is tight to ensure it did not move.

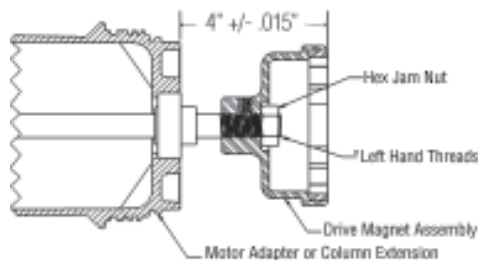

Figure 4

11. Reassemble the wet end by placing the impeller (items 18 and 19) onto the ceramic shaft in the column housing adapter (item 15). Install the housing o-ring (item 16), and lubricate with a compatible lubricant. Align the marks made on the housing (item 21) and the column housing adapter (item 15) during disassembly. Install the impeller housing (item 21) onto the column housing adapter taking care not to dislodge the o-ring. Align the bolt holes and install the six mounting screws (item 22). Use a Teflon thread lubricant on the PVDF screws. Following the pattern in Figure 5, carefully tighten using a screwdriver. Do not overtighten the screws (recommended maximum torque is 25 in-lbs. Reach into the suction and spin the impeller with your finger to verify it is not rubbing or binding.

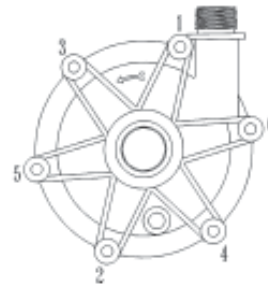

Figure 5

12. Slide the locking ring over the end of the column extension with the smaller inside diameter side toward the motor. Lubricate the column rings (item 12) with a compatible lubricant and install the "wet end" by threading it on until the flats line up. Pull the locking ring toward the pump end and snap it in place locking the two sections together.
13. Rotate the motor fan by hand to verify nothing is rubbing or binding. Reinstall the pump into the system according to the installation instructions.

GENERAL NOTES

1. Do not pump liquids containing metal fines.
2. If magnets decouple, stop the pump immediately. The rare earth magnets used in this pump are more resistant to demagnetization, but operating the pump with the magnets decoupled will eventually weaken the magnets.
3. Plastic pumps will expand and contract with temperature so periodically check and hand tighten screws.
4. Use a chemically compatible thread lubricant on threads of column sections.
5. The setting of the drive magnet dimension is critical. Failure to properly set the dimension may result in decoupling or damage to pump components.
6. An information sticker is attached to the motor adapter section. The first line is the model number, the second is the serial number. See Figure 6.

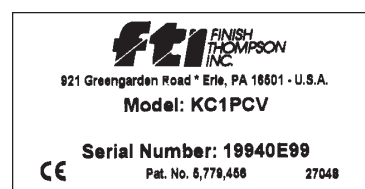

Figure 6

7. The pump will contain various numbers of shaft bearings (item 28) based on the length of the pump as follows:

12" pump	= (2) shaft bearing
18" pump	= (2) shaft bearings
24" pump	= (3) shaft bearings
30" pump	= (4) shaft bearings
36" pump	= (5) shaft bearings
42" pump	= (6) shaft bearings
48" pump	= (7) shaft bearings
54" pump	= (8) shaft bearings
60" pump	= (9) shaft bearings

8. Due to the hermetically sealed design, the pump will displace liquid as follows:

12" pump = approximately 1 gallon (3.78 liters)
 Add approximately 1 quart (.95 liter) per column section.
 E.G. 24" pump = 1-1/2 gallons (4.73 liters)

9. 12" pumps do not have column extensions.

TROUBLESHOOTING

NO DISCHARGE

- Pump not primed.
- Air lock in pump.
- Discharge head too high.
- Closed valve.
- Viscosity or specific gravity too high (magnets uncoupled).

INSUFFICIENT DISCHARGE

- Discharge head higher than anticipated.
- Clogged suction line, foot valve or crimp in hose.
- Foot valve too small.
- Foot valve or suction opening not submerged enough.
- Incorrect pump rotation

INSUFFICIENT PRESSURE

- Air or gasses in liquid.
- Impeller diameter too small.
- Discharge head higher than anticipated.
- Incorrect pump rotation.

LOSS OF PRIME

- Leaking discharge line.
- Suction lift too high or insufficient NPSHA. Should be 2 feet above NPSHR.
- Foreign matter in impeller.
- Leaking valve.
- Malfunctioning level sensor or control.

EXCESSIVE POWER CONSUMPTION

- System head lower than rating. Pumps too much liquid.
- Specific gravity or viscosity of liquid being pumped is too high or higher than defined in application.
- Binding pump parts.

VIBRATION/NOISE

- Excess bearing wear.
- Drive magnet uncoupled.
- Loose magnet.
- Pump cavitating.
- Motor or piping not properly secured.
- Foreign object in impeller.
- Set screws on motor shaft coupling loose.
- Drive magnet assembly may not be properly set or secured.

WARRANTY

Finish Thompson Inc. (manufacturer) warrants this product to be free of defects in materials and workmanship for a period of 180 days from date of purchase by original purchaser. If a warranted defect, which is determined by manufacturer's inspection, occurs within this period, it will be repaired or replaced at the manufacturer's option, provided (1) the product is submitted with proof of purchase date and (2) transportation charges are prepaid to the manufacturer. Liability under this warranty is expressly limited to repairing or replacing the product or parts thereof and is in lieu of any other warranties, either expressed or implied. This warranty does not apply to normal wear of the product or components. This warranty does not apply to products or parts broken due to, in whole or in part, accident, overload, abuse, chemical attack, tampering, or alteration. The manufacturer accepts no responsibility for product damage or personal injuries sustained when the product is modified in any way. If this warranty does not apply, the purchaser shall bear all cost for labor, material and transportation.

Manufacturer shall not be liable for incidental or consequential damages including, but not limited to process down time, transportation costs, costs associated with replacement or substitution products, labor costs, product installation or removal costs, or loss of profit. In any and all events, manufacturer's liability shall not exceed the purchase price of the product and/or accessories.

Call our toll free Technical Service Hot Line, 1-800-888-3743, if you have questions regarding product operation or repair.

ORDERING SPARE PARTS

Spare parts can be ordered from your local distributor. Always refer to pump model number to avoid error.

OTHER FINISH THOMPSON PRODUCTS

Drum Transfer Pumps, available in sanitary construction, stainless steel, polypropylene, PVDF, and CPVC, are capable of flows to 40 gpm, discharge heads to 300 feet and viscosities to 100,000 cps.

Portable Mixers for turbine mixing and blending handle viscosities to 1,000 cps with gentle, non-vortexing circulation. Available in 316 stainless steel.

Centrifugal Pumps, in polypropylene, PVDF, 316 stainless steel, and cast ductile iron are offered in mag drive sealless or mechanical seal models. Pumps are capable of 330 gpm, up to 325 feet discharge head, and 220°F (104°C) maximum.



FINISH THOMPSON INC.

921 Greengarden Road • Erie, PA 16501-1591 U.S.A.

Ph 814-455-4478 • Fax 814-455-8518

Email fti@finishthompson.com • www.finishthompson.com

Service 800-888-3743

P/N J103242, Rev. 7

Literature ID No. FT97-645G, 2/04

