

Warranty, Service & Repair

To register your product with the manufacturer, fill out the enclosed warranty card and return it immediately to:

Flowline Inc.
10500 Humbolt Street
Los Alamitos, CA 90720.

If for some reason your product must be returned for factory service, contact Flowline Inc. to receive a Material Return Authorization number (MRA) first, providing the following information:

1. Part Number, Serial Number
2. Name and telephone number of someone who can answer technical questions related to the product and its application.
3. Return Shipping Address
4. Brief Description of the Symptom
5. Brief Description of the Application

Once you have received a Material Return Authorization number, ship the product prepaid in its original packing to:

Flowline Factory Service
MRA _____
10500 Humbolt Street
Los Alamitos, CA 90720

To avoid delays in processing your repair, write the MRA on the shipping label. Please include the information about the malfunction with your product. This information enables our service technicians to process your repair order as quickly as possible.

FLOWLINE®

Ultrasonic Level Switch LU10 Series - Owner's Manual

Provided by: www.KTHSales.com



Version 4.0A
© 1999 FLOWLINE Inc.
All rights reserved.
Manual # LU900001 4/99

WARRANTY

Flowline warrants to the original purchaser of its products that such products will be free from defects in material and workmanship under normal use and service for a period which is equal to the shorter of one year from the date of purchase of such products or two years from the date of manufacture of such products.

This warranty covers only those components of the products which are non-moving and not subject to normal wear. Moreover, products which are modified or altered, and electrical cables which are cut to length during installation are not covered by this warranty.

Flowline's obligation under this warranty is solely and exclusively limited to the repair or replacement, at Flowline's option, of the products (or components thereof) which Flowline's examination proves to its satisfaction to be defective. FLOWLINE SHALL HAVE NO OBLIGATION FOR CONSEQUENTIAL DAMAGES TO PERSONAL OR REAL PROPERTY, OR FOR INJURY TO ANY PERSON.

This warranty does not apply to products which have been subject to electrical or chemical damage due to improper use, accident, negligence, abuse or misuse. Abuse shall be assumed when indicated by electrical damage to relays, reed switches or other components. The warranty does not apply to products which are damaged during shipment back to Flowline's factory or designated service center or are returned without the original casing on the products. Moreover, this warranty becomes immediately null and void if anyone other than service personnel authorized by Flowline attempts to repair the defective products.

Products which are thought to be defective must be shipped prepaid and insured to Flowline's factory or a designated service center (the identity and address of which will be provided upon request) within 30 days of the discovery of the defect. Such defective products must be accompanied by proof of the date of purchase.

Flowline further reserves the right to unilaterally waive this warranty and to dispose of any product returned to Flowline where:

- a. There is evidence of a potentially hazardous material present with product.
- b. The product has remained unclaimed at Flowline for longer than 30 days after dutifully requesting disposition of the product.

THERE ARE NO WARRANTIES WHICH EXTEND BEYOND THE DESCRIPTION ON THE FACE OF THIS WARRANTY. This warranty and the obligations and liabilities of Flowline under it are exclusive and instead of, and the original purchaser hereby waives, all other remedies, warranties, guarantees or liabilities, express or implied. EXCLUDED FROM THIS WARRANTY IS THE IMPLIED WARRANTY OF FITNESS OF THE PRODUCTS FOR A PARTICULAR PURPOSE OR USE AND THE IMPLIED WARRANTY OF MERCHANTABILITY OF THE PRODUCTS.

This warranty may not be extended, altered or varied except by a written instrument signed by a duly-authorized officer of Flowline, Inc.

SPECIFICATIONS

Step One

Accuracy: ± 1 mm in water
 Repeatability: $\pm .5$ mm in water
 Frequency: 1.5 MHz.
 Supply voltage: 12 - 36 VDC
 Consumption: Relay: 25 mA
 FET: 5mA, ± 1 mA (dry)
 19 mA, ± 1 mA (wet)
 Relay rating: 60 VDC/VAC @ 1A
 FET rating: 36 VDC max. @ 100 mA max.
 Switch output: Selectable NO or NC
 Temperature range: F: -40° to 194°
 C: -40° to 90°
 Pressure range: 150 psi (10 bar) @ 25° C., derated @ 1.667
 psi (0.113 bar) per $^{\circ}$ C. above 25° C.
 Sensor material: Polypropylene (PP) or Perfluoroalkoxy (PFA)
 Sensor rating: NEMA 6 (IP68)
 Mounting threads: Short: $3/4$ " NPT ($3/4$ " BSP)
 Long: $3/4$ " NPT ($3/4$ " G)
 Mounting gasket: Viton ($3/4$ "), metric only
 Cable type: 8 ft. (2.5 m), 4-wire (relay) or 3-wire (FET),
 22 gauge with shield & PP or PFA jacket
 CSA approval: Class I, Groups A, B, C & D;
 Class II, Groups E, F & F; Class III
 CSA entity parameters: $V_{max} = 32$ VDC
 $I_{max} = 0.5$ A
 $C_i = 0$ μ F
 $L_i = 0$ mH
 Certificate number: LR 79326-4
 CE compliance: EN 50082-2 immunity
 EN 55011 emission

Intrinsically Safe Control Drawing

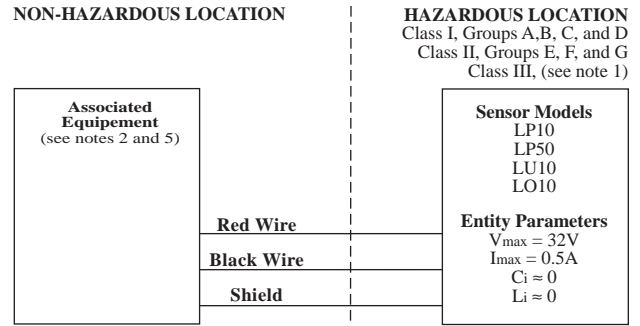

Notes:

- LP50 series sensor suitable for Class I, Groups A, B, C, and D locations only.
- CSA certified associated equipment with entity parameters.
- $V_{max} \geq V_{oc}$, $I_{max} \geq I_{sc}$, $C_i + C_{cable} \leq C_a$, $L_i + L_{cable} \leq L_a$.
- Installation should be in accordance with CEC Part I, or NFPA 70.
- Associated equipment must be installed per manufacturers instructions

Sensor Drawing: LSD1
Rev. A 7-21-95

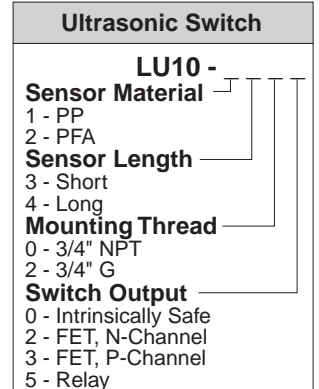
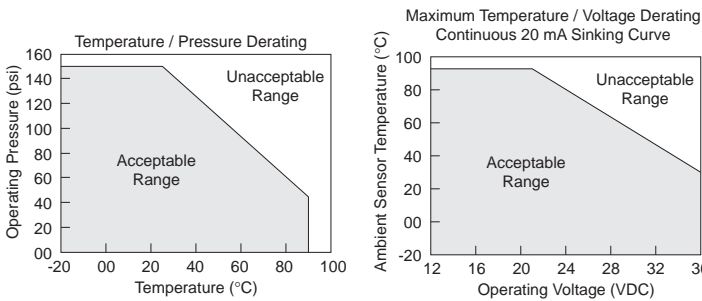

Dimensions

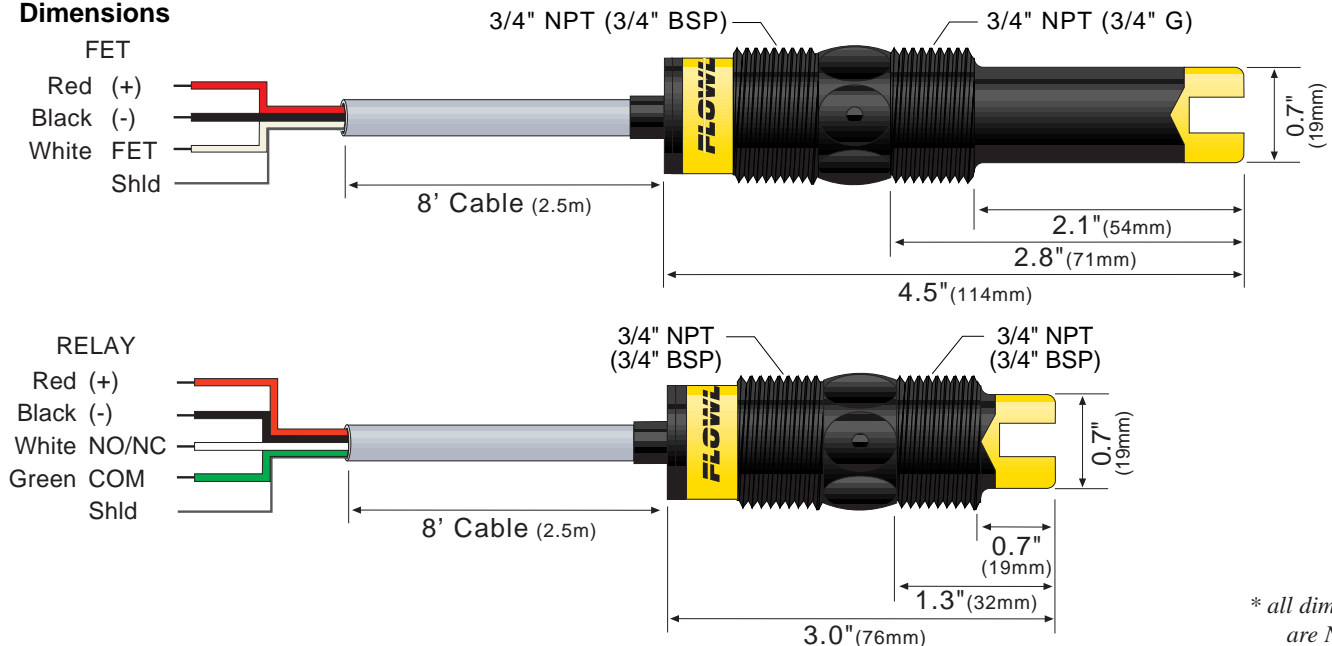

* all dimensions are Nominal

SAFETY PRECAUTIONS

Step Two

About this Manual:

PLEASE READ THE ENTIRE MANUAL PRIOR TO INSTALLING OR USING THIS PRODUCT. This manual includes information on all models of Ultrasonic level switches from Flowline, LU10 series. Please refer to the part number located on the switch label to verify the exact model which you have purchased.

User's Responsibility for Safety:

Flowline manufactures a wide range of liquid level sensors and technologies. While each of these sensors is designed to operate in a wide variety of applications, it is the user's responsibility to select a sensor model that is appropriate for the application, install it properly, perform tests of the installed system, and maintain all components. The failure to do so could result in property damage or serious injury.

Proper Installation and Handling:

Because this is an electrically operated device, only properly-trained staff should install and/or repair this product. Use a proper sealant with all installations. *Note: Always install the Viton gasket with all versions of the LU10-__2__. The G threaded version will not seal unless the gasket is properly installed.* Never overtighten the sensor within the fitting, beyond a maximum of 80 inch-pounds torque. Always check for leaks prior to system start-up.

Material Compatibility:

The LU10 series sensor is available in two different wetted materials. Models LU10-1__ are made of Polypropylene (PP). Models LU10-2__ are made of Perfluoroalkoxy, also known by the trade name Teflon, (PFA). Make sure that the model you have selected is compatible with the application liquid. To determine the chemical compatibility between the sensor and its application liquids, refer to an industry reference such as the Compass Corrosion Guide (available from Compass Publications, phone 619-589-9636).

Wiring and Electrical:

The supply voltage used to power the LU10 series sensor should never exceed a maximum of 36 volts DC. Electrical wiring of the sensor should be performed in accordance with all applicable national, state, and local codes.

Flammable, Explosive and Hazardous Applications:

Only the LU10-__0 series switch is rated for use in hazardous locations. Refer to the certificate of Compliance for all applicable intrinsically safe ratings and entity parameters for the LU10-__0. Refer to the National Electric Code (NEC) for all applicable installation requirements in hazardous locations. **DO NOT USE THE LU10-__2, LU10-__3 or LU10-__5 GENERAL PURPOSE SWITCH IN HAZARDOUS LOCATIONS.**

WARNING

The maximum current draw for the FET switch is 100 mA.

The rating for the relay is 60 VAC/60 VDC @ 1A.

Flowline's LU10 series sensors are not recommended for use with electrically charged application liquids. For the most reliable operation, the liquid being measured will need to be electrically grounded.

Always install the 3/4" Viton gasket with all versions of the LU10-__2__. The G threaded version of the ultrasonic level switch will not seal unless the gasket is installed properly.

INTRODUCTION

Step Three

About Ultrasonic Technology:

Flowline's LU10 series sensor generates a 1.5 MHz ultrasonic wave from a miniature piezoelectric transducer located on one side of the gap in its sensing tip. Another piezo transducer located on the other side of the gap acts as a microphone, picking up the sound. When liquid enters the gap in the sensing tip, the audio level changes. Flowline's sophisticated electronics convert the audio level into a signal which indicates whether the sensor is wet or dry. Depending on how the sensor is wired, this signal may be either a simple two-wire, 4 or 20 mA output (5 mA dry, 19 mA wet, for use with a current-sensing controller such as the FLOWLINE LC40 series), a three-wire FET switch, (NPN or PNP), that can be wired for normally open or normally closed circuits, or a 4-wire relay with a 1A relay output that also can be wired for normally open or normally closed circuits.

The sensor should be installed so that the liquid will drip out of the gap when the sensor becomes dry.

Flowline's LU10 series sensors are not recommended for use with electrically charged application liquids. For most reliable operation, the liquid being measured may need to be electrically grounded.

INSTALLATION

Step Four

Through Wall Installation:

Flowline's LU10 series sensors may be installed through the top, side or bottom of a tank wall. The sensor has male 3/4" NPT threads on either side of a 15/16" wrench flat. This enables the user to select the sensor's mounting orientation, installed outside of the tank in, or inside of the tank out.

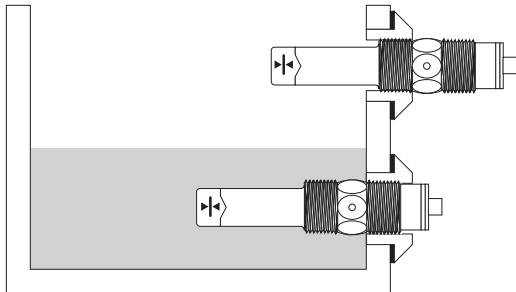

Always install the 3/4" Viton gasket with all versions of the LU10-__2. The G threaded version of the ultrasonic level switch will not seal unless the gasket is installed properly.

Smart Trak™ Installation:

Flowline's Smart Trak LM10 series mounting system is an in-tank fitting which enables users to install up to four FLOWLINE sensors of any technology, to any depth, along the entire length of track. Smart Trak may be installed through the top wall of any tank using a standard 2" NPT tank adapter. If no tank top installation is available, Flowline's side mount bracket, LM50-1001, enables Smart Trak to be installed directly to the side wall of a tank.

Switch Pak™ Installation:

Flowline's Switch Pak LM45 series mounting system is an in-tank fitting which enables users to install one FLOWLINE sensor, of any technology, to a specific depth. The Flowline sensor may be installed onto the 3/4" NPT adapter at the end of the Switch Pak. Switch Pak may be installed through the top wall of any tank using a standard 2" NPT tank adapter. Flowline's side mount bracket, model LM50-1001, may also be used if top wall installation is not available.

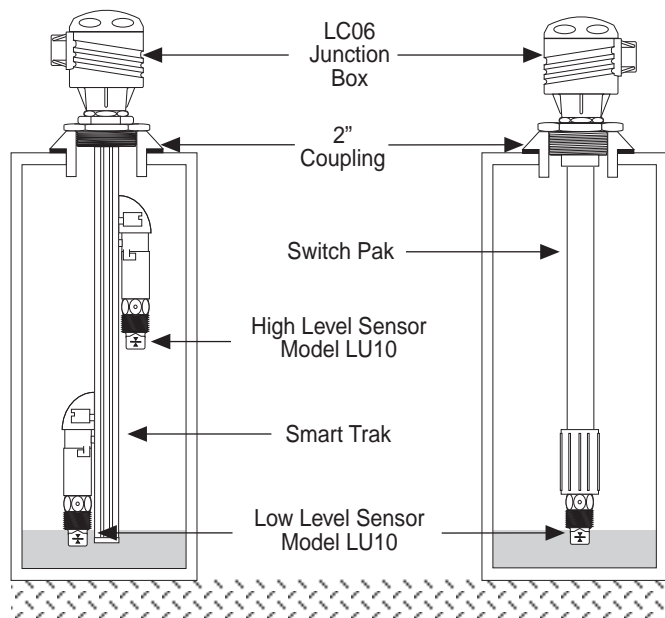

ELECTRICAL

Step Five

Supply Voltage: The supply voltage to the LU10 series sensor should never exceed a maximum of 36 VDC. Flowline controllers have a built-in 13.5 VDC power supply which provides power to all of Flowline's electrically powered sensors. Alternative controllers and power supplies, with a minimum output of 12 VDC up to a maximum output of 36 VDC, may also be used with the LU10 series sensor.

Required Cable Length: Determine the length of cable required between the LU10 series sensor and its point of termination. Allow enough slack to ensure the easy installation, removal and/or maintenance of the sensor. The cable length may be extended up to a maximum of 1000 feet, using a well-insulated, 20 gauge shielded wire.

Wire Stripping: Using a 10 gauge wire stripper, carefully remove the outer layer of insulation from the last 1-1/4" of the sensor's cable. Unwrap and discard the exposed foil shield from around the signal wires, leaving the drain wire attached if desired. With a 20 gauge wire stripper, remove the last 1/4" of the colored insulation from the signal wires.

Signal Outputs (Current sensing): The standard method used by Flowline controllers; this technology uses only two wires (Red and Black). The sensor draws 5 mA when it is dry, and 19 mA when wet. NC/NO status must be set by the controller. The White wire is not used.

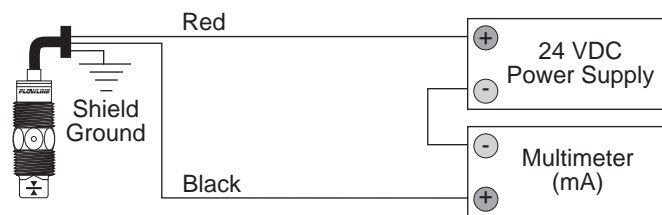

Signal Outputs (FET switching): Allows the sensor to switch a small load on or off directly, using all three wires. Model LU10-__2 is a NPN type switch, which toggles the negative side of the load; model LU10-__3 is a PNP type switch for applications where the switch must be on the positive side of the load. In both FET models, the NO/NC status is set by the polarity of the voltage feeding the Red and Black wires, and the White wire connects to the load.

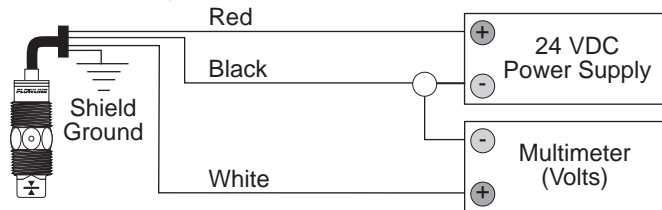

Signal Output (Relay switching): Allows the sensor to switch a small load on or off directly, using an internal 1A relay (60 VAC/60 VDC). Only model LU10-__5 uses the relay and features 4 wires (red, black, white and green) and a shield wire. The NO/NC status is set by the polarity of the voltage feeding the red and black wires. The green wire is the common for the relay and the white wire is the NO or NC, depending on the polarity of red and black.

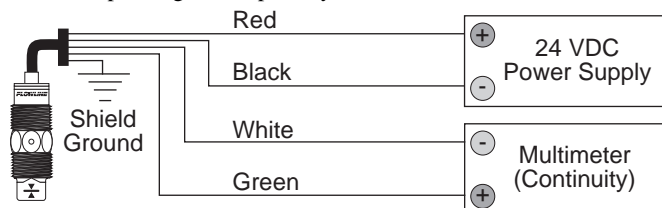

WIRING

Step Six

**Models LU10-__2, LU10-__3 & LU10-__5 Only:
Wiring to a Flowline Controller**

LC10 Series Controller
(4 or 20 mA signal output)

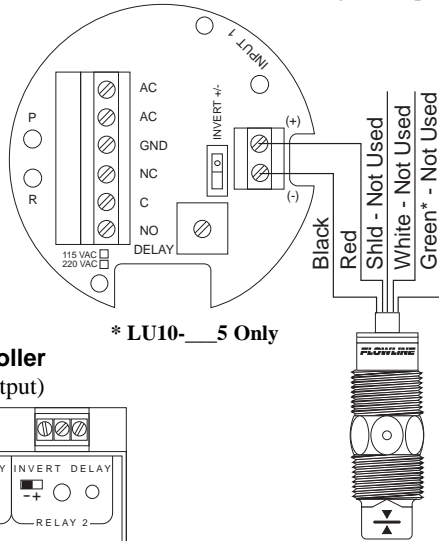

* LU10-__5 Only

LC40 Series Controller
(4 or 20 mA signal output)

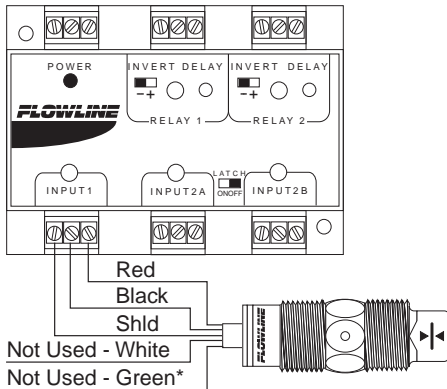

* LU10-__5 Only

WIRING

Step Seven

**Models LU10-__2 & LU10-__3 Only:
Wiring direct to a load, NC operation (FET signal output)**

LU10-__2

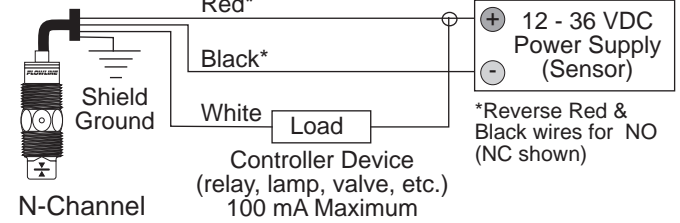

LU10-__3

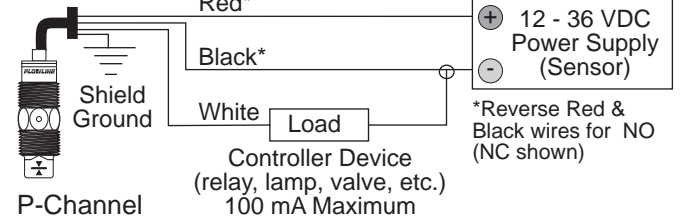

**Wiring direct to load, Normally Open operation:
LU10-__2 and LU10-__3 (FET outputs only):**

This is the same as the wiring for Normally Closed operation, except the polarity of the Red and Black connections to the sensor is reversed. The other connections remain the same; the sensor and device power supplies remain tied in the same polarity as before. This method will turn the load on when the sensor is wet.

Models LU10-__5 Only:

Wiring direct to a load, NO operation (Relay signal output)

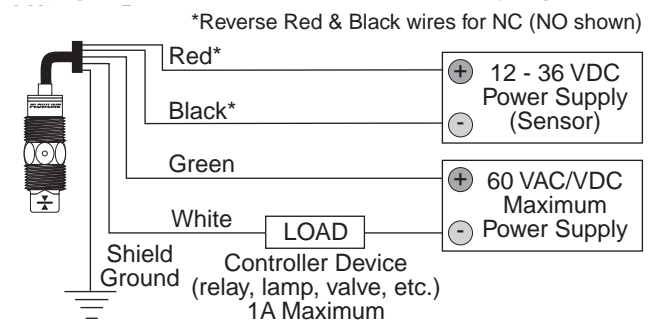

**Wiring direct to load, Normally Closed operation:
LU10-__5 (Relay outputs only):**

This is the same as the wiring for Normally Open operation, except the polarity of the Red and Black connections to the sensor is reversed. The other connections remain the same; the sensor and device power supplies remain tied in the same polarity as before. This method will turn the load on when the sensor is wet.

WIRING

Step Eight

Models LU10-__0 Only:

The LU10-__0 level switch has been approved for use in Class I, Groups A, B, C & D; UNDER CERTIFICATE NUMBER LR 79326-4. DO NOT USE THE LU10-__2, LU10-__3 OR LU10-__5 IN INTRINSICALLY SAFE APPLICATIONS. The Entity parameter for the LU10-__0 are:

$V_{max} = 32 \text{ VDC}$
 $I_{max} = 0.5 \text{ A}$
 $C_i = 0 \text{ } \mu\text{F}$
 $L_i = 0 \text{ mH}$

Intrinsically Safe Control Drawing:

NON-HAZARDOUS LOCATION

HAZARDOUS LOCATION
 Class I, Groups A,B, C, and D
 Class II, Groups E, F, and G
 Class III, (see note 1)

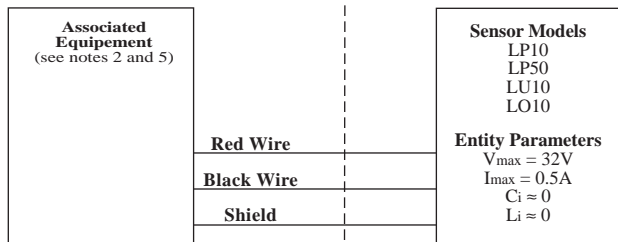

Notes:

1. LP50 series sensor suitable for Class I, Groups A, B, C, and D locations only.
2. CSA certified associated equipment with entity parameters.
3. $V_{max} \geq V_{oc}$, $I_{max} \geq I_{sc}$, $C_i + C_{cable} \leq C_a$, $L_i + L_{cable} \leq L_a$.
4. Installation should be in accordance with CEC Part I, or NFPA 70.
5. Associated equipment must be installed per manufacturers instructions

Sensor Drawing: LSD1
 Rev. A 7-21-95

Wiring to a Flowline Controller:

LC90 Series Controller

4 or 20 mA Signal Output

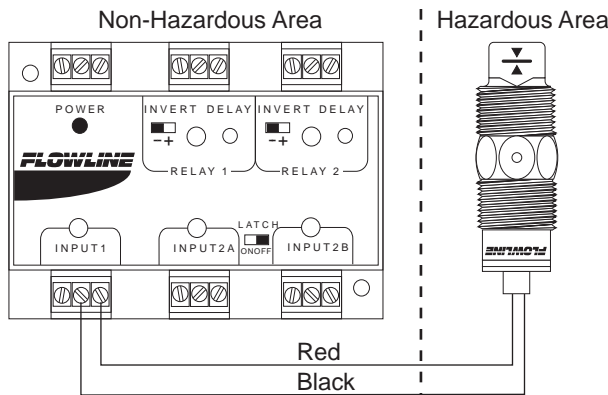

$V_{oc} = 17.47 \text{ VDC}$
 $I_{sc} = 0.4597 \text{ A}$
 $C_a = 0.494 \text{ } \mu\text{F}$
 $L_a = 0.119 \text{ } \mu\text{H}$

$V_{max} = 32 \text{ VDC}$
 $I_{max} = 0.5 \text{ A}$
 $C_i = 0 \text{ } \mu\text{F}$
 $L_i = 0 \text{ } \mu\text{H}$

MAINTENANCE

Step Nine

General:

The LU10 series sensor itself requires no periodic maintenance except cleaning as required. It is the responsibility of the user to determine the appropriate maintenance schedule, based on the specific characteristics of the application liquids.

Cleaning Procedure:

1. Power: Make Sure that all power to the sensor, controller and/or power supply is completely disconnected.
2. Sensor Removal: In all through-wall installations, make sure that the tank is drained well below the sensor prior to removal. Carefully, remove the sensor from the installation.
3. Cleaning the Sensor: Use a soft bristle brush and mild detergent, carefully wash the LU10 series sensor. Do not use harsh abrasives such as steel wool or sandpaper, which might damage the surface sensor. Do not use incompatible solvents which may damage the sensor's Polypropylene or PFA plastic body.
4. Sensor Installation: Follow the appropriate steps of installation as outlined in the installation section of this manual.