

Warranty, Service & Repair

To register your product with the manufacturer, fill out the enclosed warranty card and return it immediately to:

Flowline Inc.
10500 Humbolt Street
Los Alamitos, CA 90720.

If for some reason your product must be returned for factory service, contact Flowline Inc. to receive a Material Return Authorization number (MRA) first, providing the following information:

1. Part Number, Serial Number
2. Name and telephone number of someone who can answer technical questions related to the product and its application.
3. Return Shipping Address
4. Brief Description of the Symptom
5. Brief Description of the Application

Once you have received a Material Return Authorization number, ship the product prepaid in its original packing to:

Flowline Factory Service
MRA _____
10500 Humbolt Street
Los Alamitos, CA 90720

To avoid delays in processing your repair, write the MRA on the shipping label. Please include the information about the malfunction with your product. This information enables our service technicians to process your repair order as quickly as possible.

FLOWLINE®

FloTek™ High-Temp Vertical Level Transmitter LV50 Series Owner's Manual



Version 1.0A

© 2002 FLOWLINE Inc.

All rights reserved.

Manual # LV900005

07/02

WARRANTY

Flowline warrants to the original purchaser of its products that such products will be free from defects in material and workmanship under normal use and service for a period which is equal to the shorter of one year from the date of purchase of such products or two years from the date of manufacture of such products.

This warranty covers only those components of the products which are non-moving and not subject to normal wear. Moreover, products which are modified or altered, and electrical cables which are cut to length during installation are not covered by this warranty.

Flowline's obligation under this warranty is solely and exclusively limited to the repair or replacement, at Flowline's option, of the products (or components thereof) which Flowline's examination proves to its satisfaction to be defective. FLOWLINE SHALL HAVE NO OBLIGATION FOR CONSEQUENTIAL DAMAGES TO PERSONAL OR REAL PROPERTY, OR FOR INJURY TO ANY PERSON.

This warranty does not apply to products which have been subject to electrical or chemical damage due to improper use, accident, negligence, abuse or misuse. Abuse shall be assumed when indicated by electrical damage to relays, reed switches or other components. The warranty does not apply to products which are damaged during shipment back to Flowline's factory or designated service center or are returned without the original casing on the products. Moreover, this warranty becomes immediately null and void if anyone other than service personnel authorized by Flowline attempts to repair the defective products.

Products which are thought to be defective must be shipped prepaid and insured to Flowline's factory or a designated service center (the identity and address of which will be provided upon request) within 30 days of the discovery of the defect. Such defective products must be accompanied by proof of the date of purchase.

Flowline further reserves the right to unilaterally waive this warranty and to dispose of any product returned to Flowline where:

- a. There is evidence of a potentially hazardous material present with product.
- b. The product has remained unclaimed at Flowline for longer than 30 days after dutifully requesting disposition of the product.

THERE ARE NO WARRANTIES WHICH EXTEND BEYOND THE DESCRIPTION ON THE FACE OF THIS WARRANTY. This warranty and the obligations and liabilities of Flowline under it are exclusive and instead of, and the original purchaser hereby waives, all other remedies, warranties, guarantees or liabilities, express or implied. EXCLUDED FROM THIS WARRANTY IS THE IMPLIED WARRANTY OF FITNESS OF THE PRODUCTS FOR A PARTICULAR PURPOSE OR USE AND THE IMPLIED WARRANTY OF MERCHANTABILITY OF THE PRODUCTS.

This warranty may not be extended, altered or varied except by a written instrument signed by a duly-authorized officer of Flowline, Inc.

SPECIFICATIONS

Step One

Range:	5" to 72" (12.7 cm to 1.8m)
Accuracy:	0.25" over span in water
Specific gravity:	0.75 minimum
Orientation:	± 30° vertical
Supply voltage:	LV50: 10 to 30 VDC LV51: 10 to 40 VDC
Loop resistance:	600 Ohms @ 24 VDC
Signal output:	4-20 mA, two-wire
Signal invert:	4-20 or 20-4 mA
Calibration:	None, fixed span
Process temp.:	F: -40° to 300° C: -40° to 148.9°
Electronic temp.:	F: -40° to 160° C: -40° to 71°
Pressure:	300 psi max. 20.7 bar max.
Enclosure rating:	LV50: NEMA 4X (IP65) LV51: NEMA 7 (IP65)
Installed height:	LV50: 5.2" (13.2 cm) LV51: 6.2" (15.7 cm)
Encl. material:	LV50: PP, UL94VO LV51: Aluminum
Guide/float mat.:	316 ss
Process mount:	2" NPT
Conduit entrance:	Single, 1/2" NPT
Classification:	LV50: General purpose LV51: Explosion proof
Approvals:	FM, CSA: Class I, Division I, Groups B, (LV51 only) C & D; Class II, Groups E, F and G
CE compliance:	EN 50082-2 immunity EN 55011 emission

Technology

A single float is attached to a stainless steel rod, which is installed through the top of the tank. Internal to the rod is a series of reed switches designed to open and close as the float changes with the liquid level. The internal magnets within the float will open or close the reed switches in a "2-3-2 at-a-time" sequence, which enables the transmitter to provide accurate level indication. With every movement of the float, either one additional switch closes or opens.

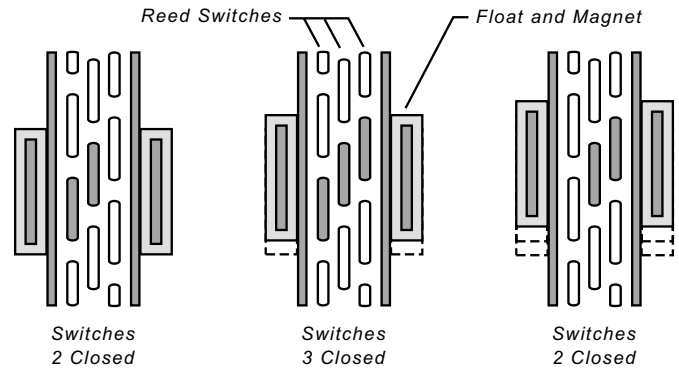

Dimensions:

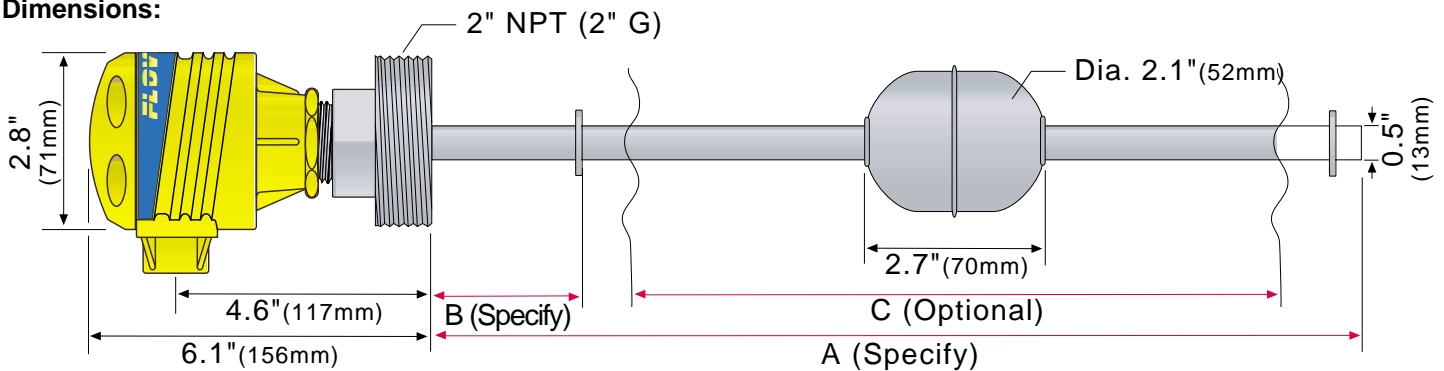

Junction Box:

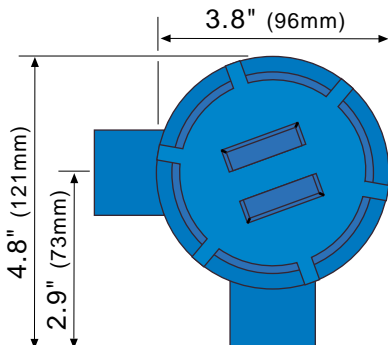

SAFETY PRECAUTIONS

Step Two

⚠ About this Manual:

PLEASE READ THE ENTIRE MANUAL PRIOR TO INSTALLING OR USING THIS PRODUCT. This manual includes information on the Flotek-Tek Level Transmitter, models LV50-S001 & LV51-S001. Please refer to the part number located on the sensor label to verify the exact model which you have purchased.

⚠ User's Responsibility for Safety:

FLOWLINE manufactures a wide range of liquid level switches and technologies. While each of these switches are designed to operate in a wide variety of applications, it is the user's responsibility to select a switch model that is appropriate for the application, install it properly, perform tests of the installed system, and maintain all components. The failure to do so could result in property damage or serious injury.

⚠ Proper Installation and Handling:

Because this is an electrically operated device, only properly trained staff should install and/or repair this product. Use a proper sealant with all installations. Never overtighten the sensor within the fitting, beyond a maximum of 80 inch-pounds torque. Always check for leaks prior to system start-up. Physical damage sustained by the product may render it unserviceable.

⚠ Material Compatibility:

The wetted portion of the Float-Point is available in 316 Stainless Steel. The junction box is made of either Polypropylene (PP) for the LV50-S001 or Aluminum for the LV51-S001. Make sure that the switch is compatible with the application liquids. To determine the chemical compatibility between the sensor and its application liquids, refer to the Compass Corrosion Guide, available from Compass Publications (858-589-9636).

⚠ Temperature and Pressure:

The LV50 series is designed for use in application temperatures up to 300 °F (148.9 °C), and for use at pressures up to 300 psi (20.7 bar). Temperature and pressure limitations must not be exceeded.

⚠ Wiring and Electrical:

The supply voltage used for the LV50-S001 should never exceed 30 VDC and for the LV51-S001 should never exceed 40 VDC. Electrical wiring of the switch should be performed in accordance with all applicable national, state, and local codes.

⚠ Flammable, Explosive and Hazardous Applications:

The LV50-S001 series switch should not be used within flammable or explosive applications. Only use the LV51-S001 series in hazardous locations when properly connected to an approved control device. In hazardous applications, use redundant measurement and control points, each having a different sensing technology. Refer to the National Electrical Code (NEC) for all applicable installation requirements in hazardous locations.

INSTALLATION

Step Three

Float-Point Installation:

FLOWLINE's Float-Point level switch is an in tank system. Float-Point may be installed through the top wall of any tank or flange, using a standard 2" NPT tank adapter or blind flange. If the top is not available, Flowline's side mount bracket, LM50-1001, enables Float-Point to be installed directly to the side wall or lip of the tank.

Tank Adapter:

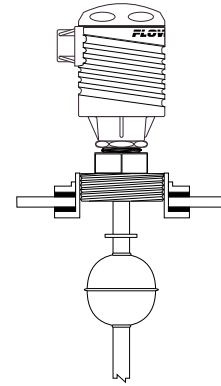

Flange Mounting:

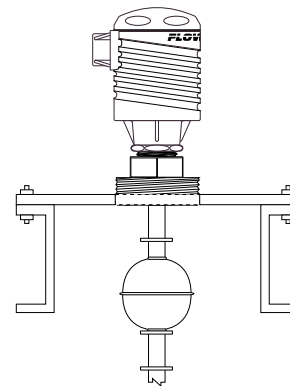

Side Mount Bracket:

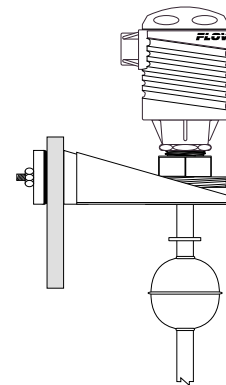

Lip of Tank:

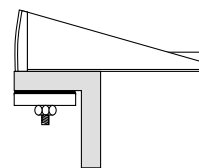

Side Wall:

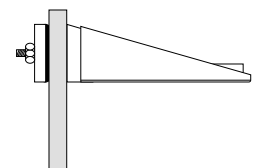

Thread Treatment:

Sealing: When threading metal threads into a metal coupling, pipe sealant or Teflon tape is recommended. When threading a metal sensor into a metal coupling, the installer should use a suitable wrench and tighten the threads 1-1/2 turns past hand tight.

WIRING

Step Four

LV50-S001:

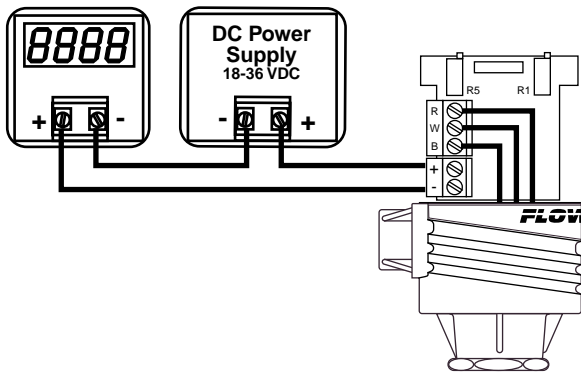

LV51-S001:

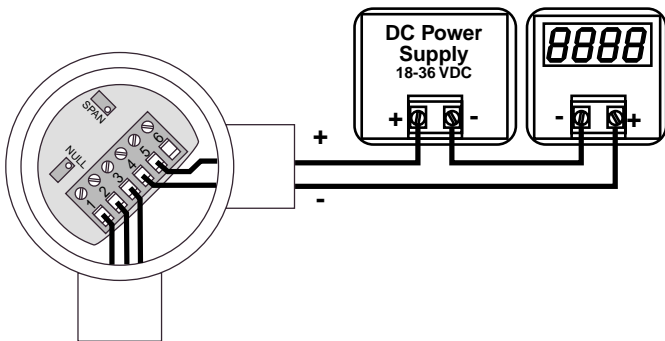

⚠ Warning ⚠

For hazardous area applications, use an appropriate intrinsically safe interface device.

MAINTENANCE

Step Five

General:

The FloTek level transmitter has no scheduled maintenance requirement, except to clean off any deposits or scaling from the switch as necessary. It is the responsibility of the user to determine the appropriate maintenance schedule, based on the specific characteristics of the application liquid.

Cleaning procedure:

- 1. Power:** Make sure that all power to the transmitter, controller and/or power supply is completely disconnected.
- 2. Switch removal:** If necessary, make sure that the tank is drained to a safe level and that the pressure is sufficient for removal of the FloTek. Carefully, remove the sensor from the installation.
- 3. Cleaning the switch:** Using a soft bristle brush and mild detergent, carefully wash the switch. Do not use harsh abrasives, which might damage the surface of the sensor. Do not use incompatible solvents which may damage the sensor's 316 ss body. Take particular care to remove any scaling from the float body and make sure that it moves freely.
- 4. Sensor installation:** Follow the appropriate steps of installation as outlined in the Installation section of this manual.

Troubleshooting:

Verify proper wiring, power supply and loop resistance. If transmitter is not functioning properly, isolate the transmitter from the system and wire as shown below. Multimeter should read 4 mA with float at the bottom and 20 mA with float at the top of the transmitter.

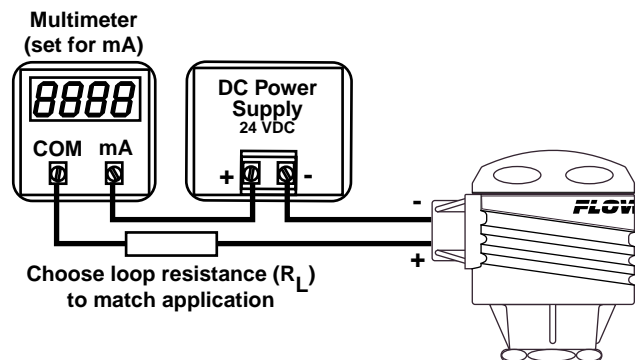

Excitation:

The minimum excitation required for operation of transmitters with 4-20 mA, DC signals can be determined for a given total loop resistance from the graph shown. (Total loop resistance = sum of the DC termination resistance plus loop resistance). For optimum operation, which is a function of source voltage (+V_A) and total loop resistance, the source voltage value used should be above the minimum load line for the related loop resistance.

