

# 103R Ball Valve

## 1-Piece Reduced Port



For Manual Service

General

Industrial

## Standard Features and Benefits

- **Economical 1-Piece Design**  
Compact unibody design delivers outstanding on/off service in a cost effective package
- **High Pressure Barstock Construction**  
Body and seals designed to perform under greater loads than standard 1-piece ball valves
- **Corrosion Resistant Trim**  
Stem and ball are made of corrosion resistant stainless steel for trouble-free service and long life
- **Blow-Out-Proof Stem**  
Stem is bottom loaded to prevent removal during operation
- **Positive Handle Stop**  
Valve uses body as a positive handle stop to ensure consistent 90° rotation

103 Pressure / Temperature Chart  
(RTFE Seats)

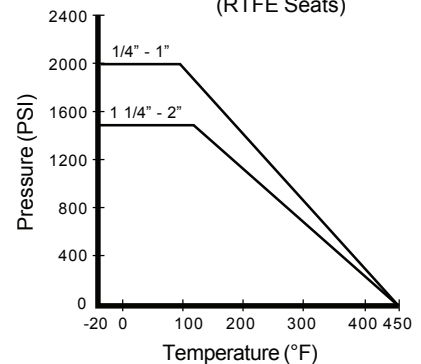

## Operating Conditions

- Temperature range (RTFE):  
-20°F ~ 450°F
- Maximum pressure (RTFE):  
2000 PSI CWP (1/4" ~ 1")  
1500 PSI CWP (1 1/4" ~ 2")

## Specifications

- All valves shell and seat tested to ANSI/ASME B16.34 and API 598



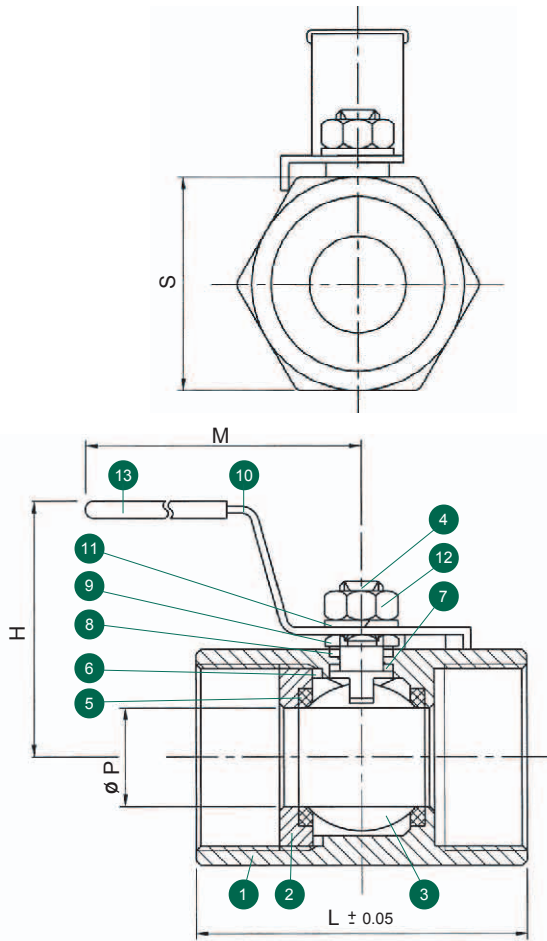

Valve Components			
#	Part Name	Material	Qty.
1	Body	S25C - CS	1
2	Insert	S25C - CS	1
3	Ball	304SS	1
4	Stem	304SS	1
5	Seat	RTFE (15% G.F.)	2
6	Body Seal	PTFE	1
7	Thrust Washer	PTFE	1
8	Stem Packing	PTFE	1
9	Packing Gland	304SS	1
10	Handle	304SS	1
11	Spring Washer	304SS	1
12	Handle Nut	304SS	1
13	Handle Cover	Vinyl	1

Dimensions (Inches)						
Size	L	P	M	H	S	Weight (lbs)
1/4	1.71	0.20	2.40	1.14	0.67	0.22
3/8	1.89	0.28	3.15	1.38	0.83	0.31
1/2	2.20	0.36	4.09	2.60	0.99	0.62
3/4	2.56	0.49	4.21	2.72	1.22	0.92
1	3.05	0.59	4.65	2.95	1.50	1.41
1 1/4	3.62	0.79	5.75	3.07	1.90	3.04
1 1/2	3.78	0.98	5.83	3.35	2.09	3.08
2	4.49	1.26	5.91	3.86	2.67	5.90

## 103R Ordering Information

Example: 2" Ball Valve with Lever Handle, Carbon Steel (CS) Body and 304SS Trim, RTFE (15% G.F.) Seats and PTFE Seals, NPT Ends

Valve Series	Valve Size	Body and Trim Material	Seat	Seal	End Connection
103R - Reduced Port	02 1/4" 03 3/8" 04 1/2" 06 3/4" 10 1" 12 1 1/4" 14 1 1/2" 20 2"	2 - A216 Gr. WCB Body A351 Gr. CF8M Trim (316)	R - RTFE (15% G.F.)	T - PTFE	T - NPT

Due to continuous product development, information may change without notice.



**INLINE INDUSTRIES, INC.**

4701-A Littlejohn Street  
Baldwin Park, CA 91706  
Tel: (626) 813-6188  
Fax: (626) 813-6186  
www.ballvalve.com  
info@ballvalve.com

Distributed by: