



*IWAKI WALCHEM  
MAGNETIC DRIVE PUMP  
MX-(F)250 to 403 SERIES  
INSTRUCTION MANUAL*

Thank you for selecting an Iwaki Walchem MX Series magnetic drive pump. This instruction manual explains the correct handling, maintenance, inspection and troubleshooting procedures for your pump. Please read through it carefully to ensure the optimum performance, safety and long service of your pump.

## TABLE OF CONTENTS

1	Unpacking and Inspection .....	1
2	Model Identification Guide .....	2
3	Specifications.....	2
4	Handling .....	7
5	Installation, Piping, and Wiring.....	9
6	Operation .....	14
7	Maintenance and Inspection .....	17
8	Troubleshooting.....	20
9	Parts Description and Exploded View.....	22
10	Disassembly and Assembly of Pump.....	24
11	Spare Parts .....	29
12	Weights and Dimensions .....	29

# 1 Unpacking and Inspection

---

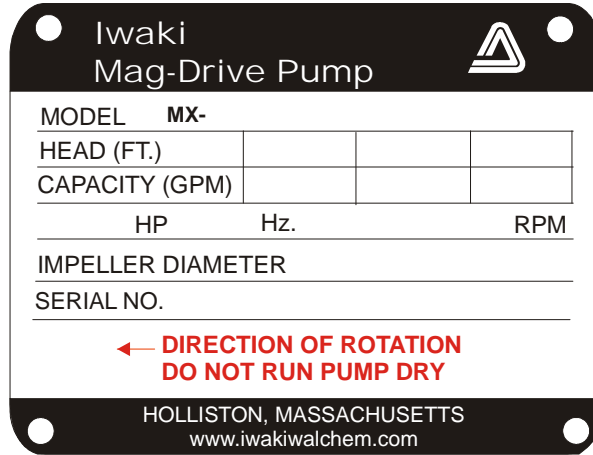

Open the package and check that the product conforms to your order. Also, check each of the following points. For any problem or inconsistency, contact your distributor at once.

1. Check that the model number and the HP indicated on the nameplate conform to the specifications of your order.
2. Check that all the accessories you ordered are included.
3. Check that the pump body and parts have not been accidentally damaged or that any bolts or nuts have not been loosened in transit.

## 2 Model Identification Guide

---

### MX(F)250-403(H)

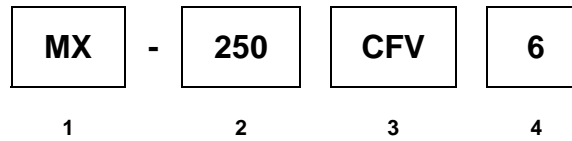

#### 1 Series Symbol

MX	GFRPP casing
MX-F	CFRETFE casing

#### 2 Pump Size

250	1" x 1"	0.5HP
251	1" x 1"	1.0HP
400	1.5" x 1.5"	0.5HP (0.75 HP larger impeller)
401	1.5" x 1.5"	1.0HP (1.5 HP larger impeller)
402H	2" x 1.5"	2.0HP
403H	2" x 1.5"	3.0HP

#### 3 Materials of Bearing/Spindle/O-ring

<i>MX</i>	
CV, CE	Carbon/Alumina ceramic/FKM (EPDM)
RV, RE	PTFE/Alumina ceramic/FKM (EPDM)
AV, AE	Alumina ceramic/Alumina ceramic/FKM (EPDM) models MX-250 to MX-401

<i>MX-F</i>	
CFV	High density carbon/High purity alumina ceramic/FKM
RFV	PTFE/High purity alumina ceramic/FKM
KKV	SiC/SiC/FKM

#### 4 Impeller Mark

<i>MX</i>	
5	50Hz only
6	60 Hz only
7	larger impeller

<i>MX-F</i>	
T, V, W	50 Hz only
X, Y, Z	60 Hz only
7	larger impeller

### 3 Specifications

Model	Suct x Disch	Max. Discharge Pressure (ft)	Max Flow (GPM)	Specific Gravity	Motor output @ 50/60Hz	Weight (less motor) lbs.	
MX-250	1" x 1"	50.9	39.6	1.0	0.5 HP	17.0	
MX-251		72.2	39.6	1.0	1 HP	22.5	
MX-400	1.5" x 1.5"	37.7	74.0	1.2	0.5 HP (0.75*)	13.7	
MX-401		55.8	84.5	1.2	1 HP (1.5*)	22.5	
MX-402	2" x 1.5"	75.5	118.9	1.2	2 HP	29.8	
MX-402H		101.7	42.3	1.0		29.8	
MX-403		98.4	132.1	1.2	3 HP	32.0	
MX-403H		121.4	66.0	1.0		32.0	
MX-F250X		44.0	39.6	1.2	0.5 HP (0.75*)	17.0	
MX-F250Y		35.1	37.0	1.5		17.0	
MX-F250Z		28.9	34.3	1.8 - 2.0		17.0	
MX-F400X		33.8	66.0	1.2		13.7	
MX-F400Y		28.2	60.8	1.5		13.7	
MX-F400Z		23.6	55.5	1.8 - 2.0		13.7	
MX-F401X	1.5" x 1.5"	50.2	71.3	1.2	1 HP (1.5*)	22.5	
MX-F401Y		42.7	68.7	1.5		22.5	
MX-F401Z		31.5	60.8	1.8 - 2.0		22.5	
MX-F402X		2" x 1.5"	69.6	116.2	1.2	2 HP	29.8
MX-F402Y			57.7	113.6	1.5		29.8
MX-F402Z			45.3	105.7	1.8 - 2.0		29.8
MX-F403X	87.6		134.7	1.2	3 HP	32.0	
MX-F403Y	73.5		132.1	1.5		32.0	
MX-F403Z	58.4		126.8	1.8 - 2.0		32.0	

\* Larger impeller size

Note 1: The specific gravity limit values shown above are with maximum discharges. The specific gravity limit varies with the discharge. For details, contact your local distributor.

Note 2: 1" tube connection option available on the MX-70 and MX-100.

Note 3: AV (E) type is different in discharge capacity. For details please contact your local distributor.

Range of liquid temperature: 0 to 80°C (10 to 80°C when AFLAS® O-rings are used.)

MX-(F)250, MX-251, MX-(F)401

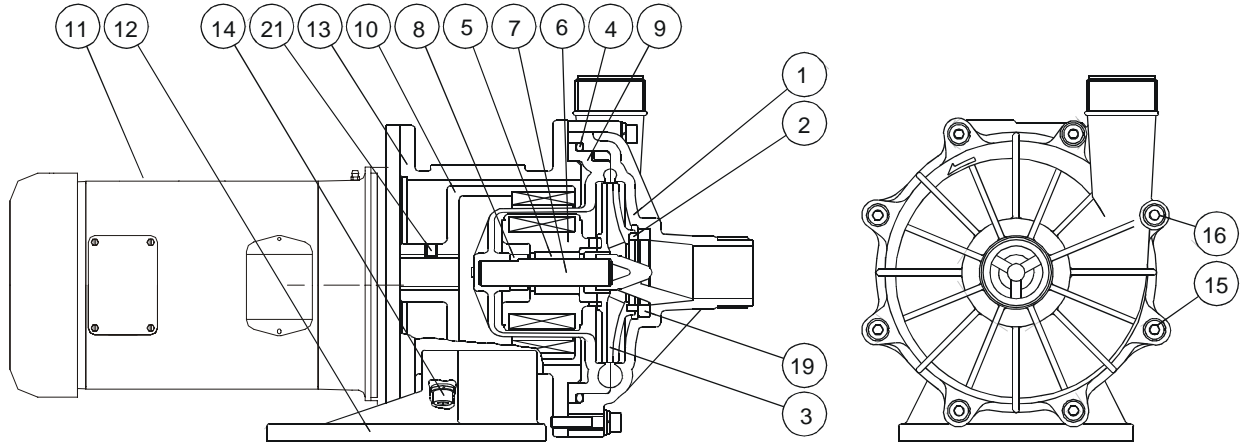

No.	Name	Qty	MX-250	MX-F250	MX-251	MX-401	MX-F401
1	Front casing	1	GFRPP	CFRETFE	GFRPP	GFRPP	CFRETFE
2	Mouth ring	1	Filler charged fluoro-resin	PTFE or SiC	Filler charged fluoro-resin	Filler charged fluoro-resin	PTFE or SiC
3	Impeller	1	GFRPP	CFRETFE	GFRPP	GFRPP	CFRETFE
4	O-ring	1	FKM JIS B 2401 G165		FKM JIS B 2401 G165		FKM JIS B 2401 G165
5	Bearing CV, CF	1	Carbon		Carbon		Carbon
	RV, RF		Filler charged fluoro-resin	PTFE	Filler charged fluoro-resin	Filler charged fluoro-resin	PTFE
	AV, KK		Alumina ceramic	SiC	Alumina ceramic	Alumina ceramic	SiC
6	Magnet capsule	1	Ferrite mag. + polypropylene	CFRETFE	Ferrite mag. + polypropylene	Ferrite mag. + polypropylene	CFRETFE
7	Spindle	1	Alumina Ceramic 99.5% or SiC		Alumina Ceramic 99.5%	Alumina Ceramic 99.5%	Alumina ceramic or SiC
8	Rear thrust	1	CFRPPS	CFRETFE	CFRPPS	CFRPPS	CFRETFE
9	Rear casing	1	GFRPP	CFRETFE	GFRPP	GFRPP	CFRETFE
10	Drive magnet unit	1	Ferrite mag. + aluminum alloy		Ferrite mag. + aluminum alloy	Ferrite mag. + aluminum alloy	
11	Motor	1	0.5 HP		1 HP	1 HP or 1.5 HP	
12	Base	1	GFRPP		GFRPP	GFRPP	
13	Motor adapter	1	FC200		FC200	FC200	
14	Hex head bolt	4	Steel M8 x 20 w/PW, SW		Steel M8 x 20 w/PW, SW	Steel M8 x 20 w/PW, SW	
15	Hex head bolt	6	SS M8 x 35 w/PW, SW		SS M8 x 35 w/PW, SW	SS M8 x 35 w/PW, SW	
16	Hex head bolt	2	SS M8 x 50 w/PW, SW		SS M8 x 50 w/PW, SW	SS M8 x 50 w/PW, SW	
18	Flange kit	2	GFRPP	CFRETFE	GFRPP	GFRPP	CFRETFE
19	Liner ring	1	Alumina ceramic 99.5% or SiC		Alumina Ceramic 99.5%	Alumina Ceramic 99.5% or SiC	
21	Hex head screw	2	Steel M8 x 10		Steel M8 x 10	Steel M8 x 10	

MX-(F)400

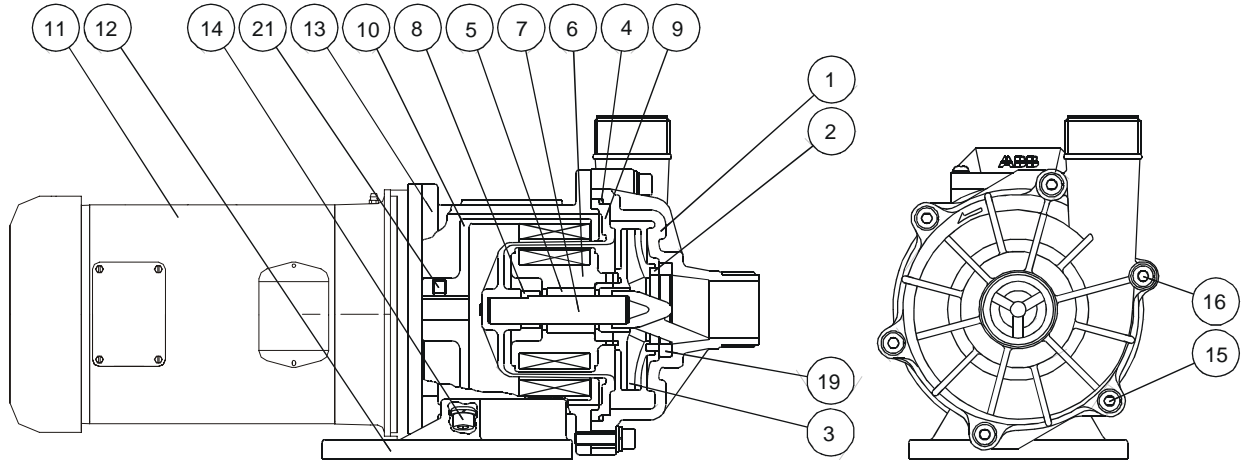

No.	Name	Qty	MX400	MX-F400
1	Front casing	1	GFRPP	CFRETFE
2	Mouth ring	1	Filler charged fluoro-resin	PTFE/SiC
3	Impeller	1	GFRPP	CFRETFE
4	O-ring	1	FKM JIS B 2401 G135	
5	Bearing CV, CF	1	Carbon	
	RV, RF		Filler charged fluoro-resin	PTFE
	KK			SiC
6	Magnet capsule	1	Rare earth magnet + polypropylene	Rare earth magnet + CFRETFE
7	Spindle	1	Alumina ceramic 99.5%	Alumina ceramic or SiC
8	Rear thrust	1	CFRPPS	CFRETFE
9	Rear casing	1	GFRPP	CFRETFE
10	Drive magnet unit	1	Rare earth magnet + FCD450	
11	Motor	1	1 or 1.5 HP	
12	Base	1	GFRPP	CFRETFE
13	Motor adapter	1	FC200	
14	Hex bolt	4	Steel M8 x20 w/PW, SW	
15	Hex head bolt	4	SS M8 x 30 w/SW	
16	Hex head bolt	2	SS M8 x 40 w/PW, SW	
18	Flange kit	2	GFRPP	CFRETFE
19	Liner ring	1	Alumina ceramic 99.5%	Alumina ceramic or SiC
21	Hex head screw	2	Steel M8 x 10	

MX-(F)402(H), MX-(F)403(H)

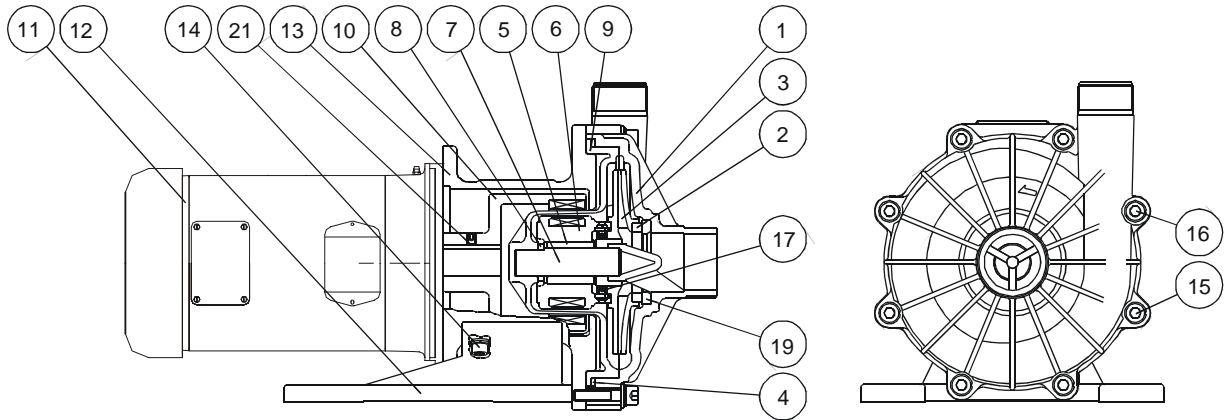

No.	Name	Qty	MX-402(H), 403(H)	MX-F402, F403
1	Front casing	1	GFRPP	CFRETFE
2	Mouth ring	1	Filler charge fluoro-resin	PTFE or SiC
3	Impeller	1	GFRPP	CFRETFE
4	O-ring	1	FKM JIS B 2401 G195	
5	Bearing CV, CF	1	Carbon	
	RV, RF		Filler charge fluoro-resin	PTFE
	AV, KK		Alumina ceramic	SiC
6	Magnet capsule	1	Ferrite mag. + polypropylene	Ferrite mag. + CFRETFE
7	Spindle	1	Alumina ceramic 99.5%	Alumina ceramic or SiC
8	Rear thrust	1	CFRPEEK	CFRPFA
9	Rear casing	1	GFRPP	CFRETFE
10	Drive magnet unit	1	Ferrite mag. + aluminum alloy	
11	Motor	1	2 + 3 HP	
12	Base	1	GFRPP	
13	Motor adapter	1	FC200	
14	Hex head bolt	4	Steel M8 x 20 w/PW, SW	
15	Hex head bolt	6	SS M10 x 30 w/ SW	
16	Hex head bolt	2	SS M10 x 60 w/PW, SW	
17	Lock pin	2	CFRPPS	CFRETFE
18	Flange kit, discharge	2	GFRPP	CFRETFE
19	Liner ring	1	Alumina ceramic 99.5%	Alumina ceramic or SiC
20	Motor bolt	4	SS 3/8 x 3/4"	
21	Hex head screw	2	Steel M8 x 10	
22	Flange kit, suction	1	GFRPP	CFRETFE

## 4 Handling



### CAUTION

#### **Do not run pump dry**

When the pump is operated for the first time after it was installed or after it was disassembled and repaired, fill the pump chamber with the liquid to be pumped. If the pump runs dry without any liquid, rubbing parts of pump will seize. The rubbing parts of MX pump are lubricated and cooled by the pumped liquid. The pump will be damaged if run dry or with the suction side valve fully closed. If the pump runs dry by mistake, switch off the power and leave it for more than one hour to cool it down slowly.

#### **Keep pump away from fire**

To prevent fire and explosions, do not place dangerous or inflammable substances near to pump.

#### **No remodeling**

Remodeling the pump can cause risk of injury or electrical shock.

### **Precautions on handling**

1. Precautions when pump is started or stopped  
When discharge line is long and to avoid water hammer, pay attention to the following:
  - a. When pump is started  
After priming, close the discharge valve before power is switched on. After the pump is started, gradually open the discharge valve to get the desired duty point.
  - b. When pump is stopped  
Gradually close the discharge valve and switch off the power. Never close the discharge line suddenly with a solenoid valve. Sudden close of discharge line causes water hammer resulting in pump damage.
2. Do not install or store pump in the following places.
  - Where the temperature falls below 0 deg. C.
  - Where there is corrosive or explosive gas.
  - Where water is splashed (except the pump equipped with weather-proof motor)
  - Where ambient temperature exceeds 40 deg. C.
  - Where humidity exceeds 85% (Allowable humidity : 35 to 85%RH)
  - Where there is risk of powder, fire, earthquake and external shock.
3. Prime pump  
The pump is not self-priming. Before the pump is started, prime the pump with pumped liquid. Dry running causes seizure and quick wear of parts.

4. Pump allowable pressure  
Pump allowable pressure is shown below. Do not allow discharge pressure to exceed the allowable pressure.

Model MX-	(F)250	251	(F)400	(F)401	(F)402, 403	402H .403H
Max. allowable pressure PSI (MPa)	36.3 (0.25)	47.9 (0.33)	31.9 (0.22)	40.6 (0.28)	62.4 (0.43)	72.5 (0.5)

5. Liquids to be transferred
- a. Liquid containing slurry  
Slurry can not be handled except for type AA (with alumina ceramic bearing) which can handle slurry liquid up to 5% concentration, slurry size of 50 micron m or below and hardness up to 80Hs. Contact Iwaki Walchem if you wish to handle slurry liquid.
  - b. Performance influenced by specific gravity and viscosity of liquid  
Liquid which is heavier or more viscous than water influences the shaft power, discharge capacity and head.  
The pump you purchased is made according to the specifications you gave us when ordered. If you wish to change the conditions, please contact us.
  - c. Alumina ceramic bearing (types AV, AE, AA) may be worn in a short time depending on the characteristics of liquid (low viscosity or so). Please ask us if you have any question.
  - d. Influence by temperature  
Pump performance is not influenced by the change of liquid temperature , however, the temperature will affect the viscosity, vapor pressure and chemical corrosivity. Refer to the chemical resistance table for the permissible temperature for specific chemical liquids.  
Temperature of liquid to be handled : 0 – 80 deg. C ( for water)  
Permissible ambient temperature : 0 – 40 deg. C  
Permissible humidity : 35 – 85% RH
6. Intermittent operation  
Frequent stopping and starting run may cause pump damage. Keep the start/stop frequency to within six times an hour.
7. Disconnection of magnet coupling  
If the magnet coupling is disconnected, stop the pump within a minute. If the pump runs with the magnet coupling disconnected, the power of coupling will be decreased.

8. Use of pump in the range of bell-shaped pump performance curve  
For the pump which shows bell-shaped performance curve in a small capacity range (Refer to standard performance curve of the pump), if this pump is used at the section of the curve that ascends, the pump may operate unstable and make vibration or noise. To avoid such a surging operation, pay attention to the following:
- Arrange the discharge piping so that air pockets are prevented.
  - Install the valve near the pump discharge port to adjust discharge capacity.

## 5 Installation, Piping, and Wiring

---



### WARNING

#### **Switch off power**

Be sure someone does not switch power on when the pump is being maintained. Display a sign near the power supply switch to notify others that the pump is being maintained.

#### **Do not hold plastic parts when transferring pump**

When transferring the pump, do not hold plastic parts such as casing, flange or base. Plastic parts may break and the pump may fall resulting in personal injury. The weight of pump is approx. 20 kg max. Put the pump and motor horizontally with the base downward.

#### **Electrical work**

Electrical work should be done by qualified personnel.

### ■ Installation Position

1. Install the pump as close to the suction tank as possible (flooded suction). If the suction port of the pump is positioned higher than the suction tank (suction lift), be sure to arrange a foot valve in the priming pipe and the suction pipe. The lifting capability depends upon the liquid properties, temperature, and length of suction piping. For details, consult Iwaki Walchem or your distributor.
2. The pump can be installed indoors or outdoors. However, there should be sufficient space around the pump to enable efficient and easy maintenance.

## ■ Installation

1. The pump anchoring area must be greater than the area of the pump baseplate. If the anchoring area is not large enough, the baseplate may be damaged due to the concentration of loads placed on it.
2. Set the pump baseplate on a concrete foundation and fasten the anchor bolts tightly to prevent the pump from vibrating during operation. A sturdy metal (or reinforced) skid or platform is also an acceptable mounting surface.
3. In case there is influence of motor vibration during operation (e.g., sympathetic vibration with piping), an expansion joint should be provided between the pump and the piping before the installation. Otherwise, pipes and gauges may be damaged.
4. MX series pumps should always be mounted horizontally.

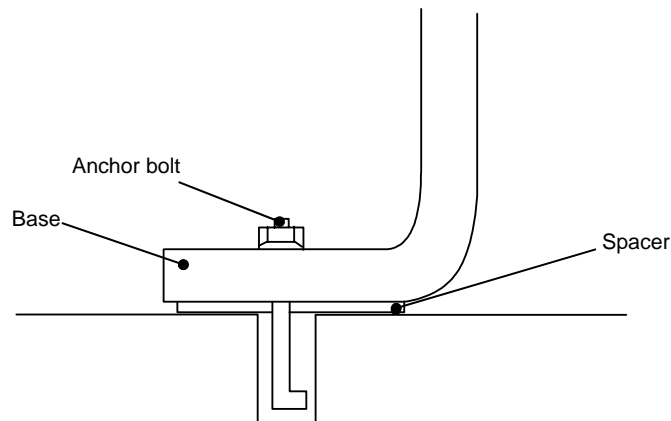

Fig. 3

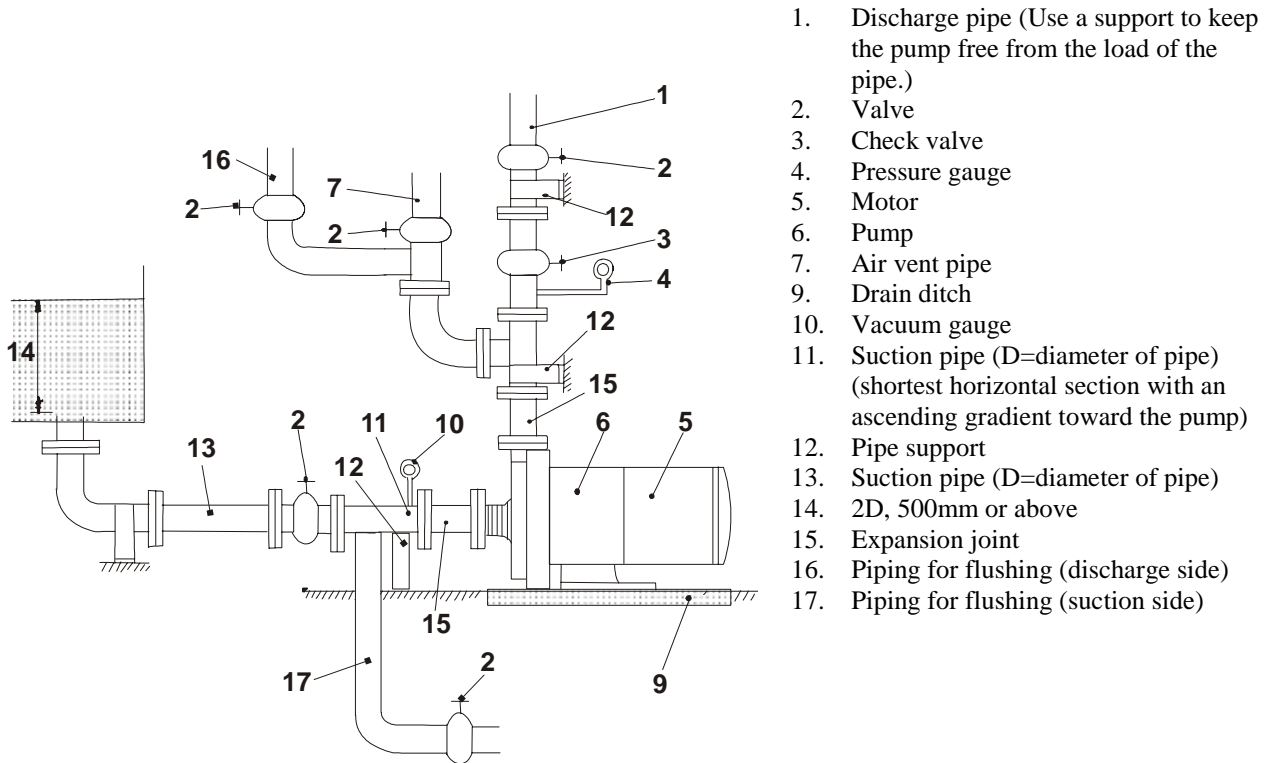

Fig. 4

## ■ Suction Piping

1. The suction pipe should employ the flooded suction method if possible. The shortest pipe possible, with the minimum number of bends, should be designed. Arrange a proper support on the suction pipe so that the load and the thermal stress of the pipe itself are not applied to the pump.
2. Attach the coupling on the suction pipe carefully, so that no air enters the line. The presence of air in the suction pipe may prevent priming of the pump.
3. Avoid installations with poor suction conditions (e.g. vacuum in suction tank, large suction head or long suction piping). NPSHa should always be at least 2 feet greater than NPSHr. For NPSHr values, refer to the standard performance curve for your pump model or contact Iwaki Walchem or your distributor.
4. When using a bend on the suction side, install a straight pipe which is more than 20 inches long or 10 times as long as the suction port diameter before the suction port of the pump. Use the largest possible radius of curvature for the bend.
5. Do not allow any projection where air may be trapped along the suction pipe. The suction pipe should have an ascending gradient toward the pump.
6. If the diameters of the pump suction port and the suction pipe are different, use an eccentric reducer pipe. Connect the eccentric reducer pipe such that the upper part of it is level. **Never use a suction pipe with a diameter smaller than that of the suction port.**

7. When using the flooded suction method, the suction pipe should be given a slight ascending gradient toward the pump so that no air pocket is created on the suction side.
8. The end of the suction pipe should be located 18 inches or more below the surface of the liquid.
9. A screen should be provided at the inlet of the suction tank to prevent the entrance of foreign matter into the suction pipe. Foreign matter may cause malfunctioning of the pump. The end of the suction pipe should be at least 1- 1.5D from the bottom of the suction tank. (D=Diameter of suction pipe).
10. When employing the suction lift method, install a foot valve on the suction pipe.
11. When using the flooded suction method, it is recommended that a gate valve be installed on the suction pipe for easier overhaul inspection of the pump. Since this valve is used only in the overhaul inspection of the pump, keep it fully opened during normal pump operation.

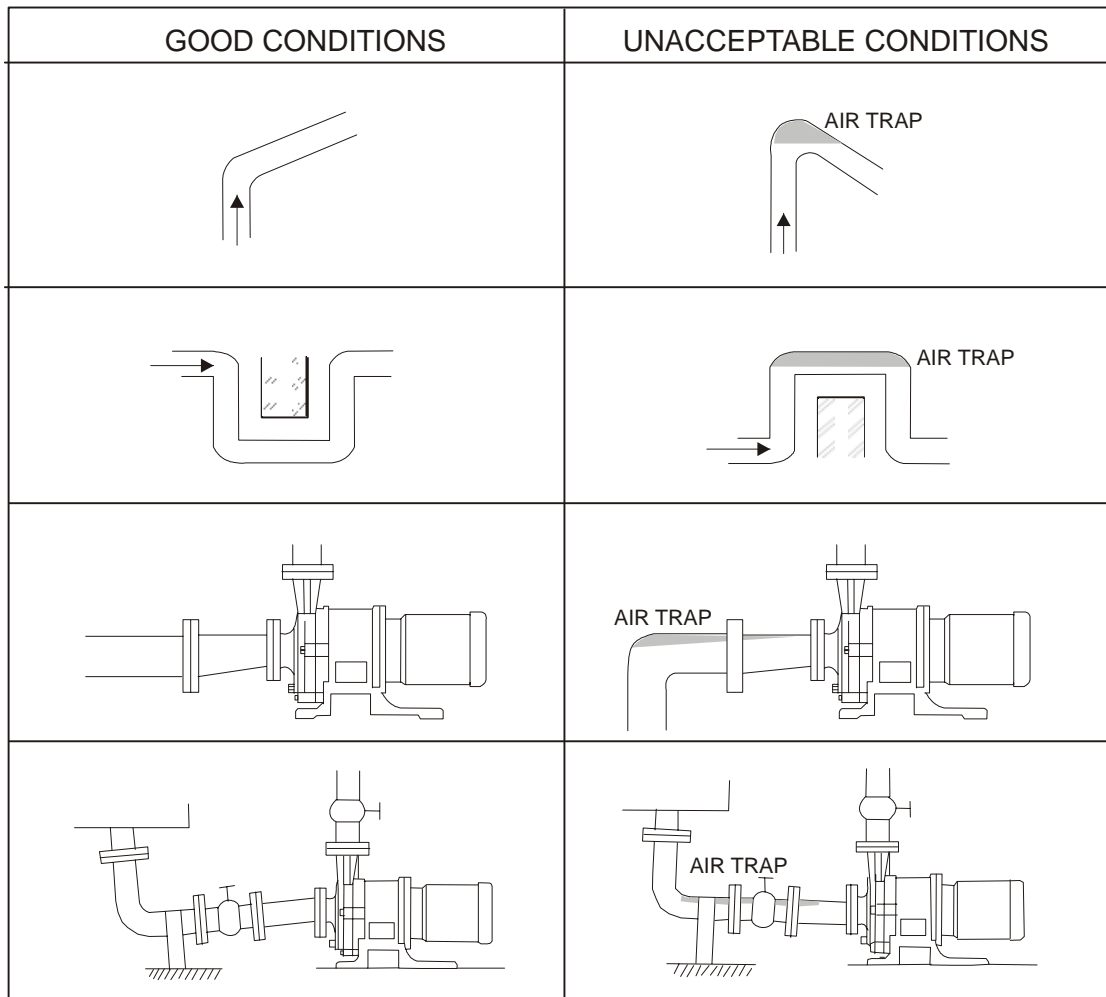

Fig. 5

12. Pay close attention to the lowest level of the liquid in the suction tank so that air entrainment to the suction piping will not occur.

The inflow pipe into the suction tank should be distanced from the suction pipe and positioned below the liquid surface as a means of preventing air entrainment to the suction pipe. If air bubbles are generated in the suction tank, install a baffle.

13. It is recommended that a vacuum/pressure gauge be installed on the suction piping approximately 6 pipe diameters from the pump suction port.

### ■ Discharge Piping

1. Use proper pipe supports so that the weight of the piping does not load the pump nozzle.
2. If a method other than flooded suction is used, install a special pipe for priming.
3. If the piping is very long, its diameter should be determined by calculating the piping resistance. Otherwise, the specified performance may not be obtained due to increased piping resistance.
4. A check valve should be installed if any of the following conditions exists in the piping:
  - The discharge piping is very long.
  - The discharge head is 50 feet or more.
  - The end of the discharge pipe is located 30 feet higher than the surface of the suction tank.
  - Several pumps are connected in parallel with the same piping.
5. The installation of a gate valve on the discharge pipe is recommended for the adjustment of discharge quantity and for the prevention of motor overload. When installing both a check valve and a gate valve, the check valve should be positioned between the pump and the gate valve.
6. A pressure gauge must be installed on the discharge piping.
7. An air bleeding valve should be installed if the discharge pipe is very long in the horizontal direction.
8. A drain valve should be installed for the drainage of liquid if there is a chance that the liquid in the discharge pipe will freeze.

## ■ Wiring

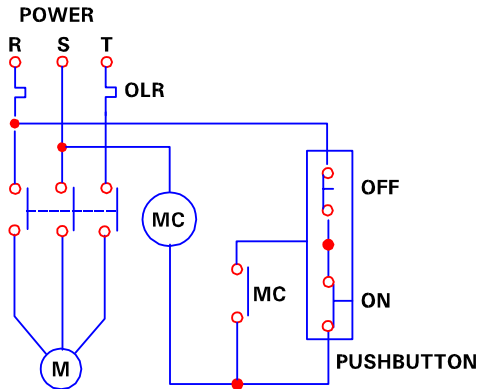

**M** Motor  
**MC** Motor contactor  
**ON** — Push Button  
**OFF** — Push Button  
**CLR** Overload relay

Fig. 6

Use appropriate wiring materials, follow the instruction manual for the motor and abide by the local and national electrical codes. In addition, follow the instructions given below:

1. Use a motor contactor that conforms to the specifications (voltage, current, etc.) of the pump motor.
2. If the pump is installed outdoors, use waterproof wiring to protect the switches from rainwater and moisture.
3. The motor contactor and push button should be installed a reasonable distance from the pump.
4. Refer to the wiring example shown on the left. (This example does not include the installation of a dry-operation prevention device. Follow the instruction manual of the dry-operation prevention device when installing it.)

## 6 Operation

---

### ■ Notes on Operation

1. Never operate the pump with the suction-side valve (gate valve) closed. Otherwise, the internal bushings of the pump will be damaged.
2. In the event of cavitation, stop the pump immediately.
3. If the magnet coupling disconnects, stop the pump immediately. The torque rating of the magnet coupling will be reduced if operation is continued with the coupling disconnected.
4. Liquid temperature fluctuation should not exceed 176° F when starting, stopping, and operating the pump.
5. Be sure to close the discharge valve completely before starting operation in order to prevent water hammer upon start-up.
6. The pump should never be operated for a lengthy period with the discharge valve closed. A resulting rise in temperature of liquid in the pump may cause damage to the pump.
7. In the event of a service power failure, turn off the power switch immediately and close the discharge valve.

## ■ Start-Up Preparation

When operating the pump for the first time after installation, and when restarting operation after a long interval, prepare for operation as described below.

1. Thoroughly clean the inside of the piping and pump.
2. Tighten the union fittings or flange connecting bolts and baseplate installation bolts. Check that bolts which couple the front casing and the bracket together are securely fastened.
3. Close the cocks of any pressure or vacuum gauges to prevent damage from sudden pressure changes. Open only when taking measurements.
4. Fully open the suction gate valve and partly open the discharge valve. Discharge valve may be adjusted after completion of priming and start-up process.
5. Use a screwdriver to rotate the motor fan and check that the fan rotates smoothly. This also purges any residual air from in and around the impeller.
6. If using flooded suction, measure the pressure in the suction pipe to check that the pump is filled with liquid.
7. Run the motor momentarily to check the direction of motor rotation. The motor should run in the direction indicated by the arrow sealed on the pump. If the direction is reversed, exchange two wires of the three-phase power wires.

Note: All Iwaki Walchem MX-(F) series pumps spin counter-clockwise when looking at the suction port of the pump. Naturally, from the motor fan side, this would be viewed as clockwise.

## ■ Starting Operation

Pump operation is detailed below.

Check/Operation Step	Remarks
1. Verify valve position.	Suction valve fully open. Discharge valve fully closed.
2. Check that the pump is filled with liquid.	If pump is not filled with liquid, fill it in accordance with steps 5-6 of 'Start-up Preparation'.
3. Turn ON motor switch momentarily and check for correct direction of pump operation.	See the arrow on the casing to confirm the direction of rotation (clockwise when viewed from the motor fan side).

Check/Operation Step	Remarks
4. Flow rate adjustment. Once total discharge pressure is increased to shut off pressure. Open discharge valve gradually to set discharge pressure to desired specification.	Open valve slowly, paying attention to the motor amp meter to prevent it from being overloaded through excessive opening of the valve.
Pump should be operated at a minimum flowrate: 250,251,400,401: 2.5 Gal/min (10L/min) or more  In case of automatic control, close discharge valve when starting pump and gradually open the discharge valve thereafter. Don't operate the pump with the discharge valve closed for more than one minute.	
5. Points to be observed during operation. If pump enters continuous operation check flow meter and confirm that pump operation meets specifications.	If flowmeter is unavailable, check values of discharge pressure, suction pressure and current in relation to piping resistance.

### ■ Stopping Operation

Check/Operation Step	Remarks
1. Close discharge valve gradually.	 Caution Do not cause sudden closure by using solenoid valve, etc. Otherwise, pump may be damaged by water hammer.
2. Stop motor.	Observe that the motor stops rotating slowly and smoothly. If not, check inside of pump.
3. Points to be observed when stopping pump. If pump operation is stopped in cold weather, liquid inside the pump cavity may freeze and damage the pump. Be sure to drain liquid completely. In case of short-term shut down, which does not allow removal of liquid, use band heater, etc., to prevent liquid from freezing. In case of service power failure turn OFF power switch and close discharge valve.	

## 7 Maintenance and Inspection

---

### ■ Daily Inspection

1. Check that the pump operates smoothly, without generating abnormal sounds or vibration.
2. Check the level of the liquid in the suction tank, and the suction pressure.
3. Compare the discharge pressure and current measured during operation with the specifications indicated on the motor and pump nameplates to verify normal pump load.

\* Note that the indicated value of the pressure gauge varies in proportion to the specific gravity of the liquid.



**Caution** The valve of the pressure gauge or vacuum gauge should be opened only when measurements are recorded. It must be closed after completion of each measurement. If the valve remains open during operation, the gauge mechanism may be affected by abnormal pressure caused by water hammer.

4. If a spare pump is included in the installation, keep it ready for use by operating it from time to time.

### ■ Periodic Inspection

To ensure efficient, smooth operation of the pump, carry out periodic inspection by following the procedure described below. When carrying out an overhaul inspection, handle the internal bushings and plastic components most carefully. Since the outer drive magnet and inner magnet capsule are very powerful, handle these components with caution. Take care not to trap hands and fingers between the magnets and metal objects. Also avoid positioning the magnets near any electronic device (or ATM cards with magnetic strips) that could be affected by a strong magnetic field.

<b>Inspection Interval</b>	<b>Part</b>	<b>Inspection Points</b>	<b>Operator Action</b>
Every 6 months *Inspection record should be maintained	Drive magnet assembly	<ul style="list-style-type: none"> <li>• Is there scoring?</li> <li>• Is magnet mounted normally? Are hexagonal socket setscrews loose?</li> <li>• Are inner perimeters of magnet and motor shaft concentric?</li> </ul>	<ul style="list-style-type: none"> <li>• Contact distributor if any abnormality is observed.</li> <li>• Re-install magnet on motor shaft &amp; fasten setscrews.</li> <li>• Re-tighten or replace setscrews.</li> </ul>
Every 3 months *Inspection record should be maintained	Rear casing	<ul style="list-style-type: none"> <li>• Scoring on inner diameter?</li> <li>• Cracks in section containing liquid?</li> <li>• Stain in rear casing?</li> </ul>	<ul style="list-style-type: none"> <li>• Contact distributor if any abnormality is observed.</li> <li>• Replace if abnormality is observed.</li> <li>• Clean</li> </ul>
	Magnet capsule	<ul style="list-style-type: none"> <li>• Scoring in rear face or cylindrical body?</li> <li>• Cracks in the plastic of the rear section or cylindrical body?</li> <li>• Bearing wear?</li> </ul>	<ul style="list-style-type: none"> <li>• Contact your distributor if any abnormality is observed.</li> <li>• Contact your distributor if any abnormality is observed.</li> <li>• Replace if abnormality is observed (see Tolerance Chart).</li> </ul>
	Impeller	<ul style="list-style-type: none"> <li>• Any cracks?</li> <li>• Cavitation marks?</li> <li>• Stain or clogging inside impeller?</li> <li>• Dimensional change of impeller?</li> <li>• Conical thrust wear?</li> </ul>	<ul style="list-style-type: none"> <li>• Replace if abnormality is observed.</li> <li>• Eliminate cause.</li> <li>• Clean.</li> <li>• Replace if abnormality is observed.</li> <li>• Replace if abnormality is observed (see Tolerance Chart).</li> </ul>
Every 3 months *Inspection record should be maintained	Front casing	<ul style="list-style-type: none"> <li>• Stain in section containing liquid?</li> <li>• Cracks?</li> <li>• Wear or crack of thrust ring?</li> <li>• Expansion or wear of o-ring?</li> <li>• Scoring on inner surface?</li> </ul>	<ul style="list-style-type: none"> <li>• Clean.</li> <li>• Replace if abnormality is observed.</li> <li>• Contact distributor if abnormality is observed.</li> <li>• Replace if part is damaged.</li> <li>• Contact distributor if abnormality is observed.</li> </ul>
	Spindle	<ul style="list-style-type: none"> <li>• Cracks?</li> <li>• Wear on surface?</li> </ul>	<ul style="list-style-type: none"> <li>• Replace if abnormality is observed.</li> <li>• Replace if wear limit is exceeded.</li> </ul>

■ **Wear Limits of Spindle, Bearing, Mouth Ring & Impeller Thrust**

Model MX-(F)	250, 251, 400, 401		402, 402(H), 403, 403(H)	
	New	Replace	New	Replace
Bearing I.D. inches (mm)	0.709 (18)	0.748 (19)	.945 (24)	.984 (25)
Spindle O.D inches (mm)	0.709 (18)	0.669 (17)	.945 (24)	.906 (23)

If the difference between Bearing I.D. and Spindle O.D. exceeds 0.039 in. (1mm), either the bearing or the spindle, whichever has the greater wear, should be replaced regardless of the values in the above table. In case of a ceramic bearing type pump (MX-250-401), the spindle and the bearing should be replaced simultaneously.

Initial wear may appear on the sliding parts during the first stages of operation. This should not be mistaken for an abnormal condition.

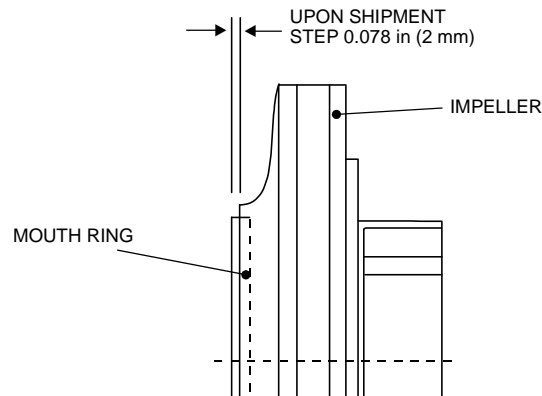

MX-(F)	250, 251, 400, 401, 402(H), 403(H)	
Thickness of mouth ring inches (mm)	New	Replace
	0.315 (8)	0.236 (6)

The step between the surfaces of the mouth ring and the impeller upon shipment is 0.078 in. (2mm) (0.118 in. (3mm) for MX-250). Replace the mouth ring when this step is reduced to 0 in.

## 8 Troubleshooting

Trouble	Symptom on Pump		Cause	Inspection & Countermeasures
	With discharge valve closed	With discharge valve open		
		Pressure gauge and vacuum gauge indicate 'zero'	<ul style="list-style-type: none"> <li>Insufficient priming</li> <li>Dry operation</li> </ul>	<ul style="list-style-type: none"> <li>Stop pump, feed priming liquid &amp; restart pump.</li> </ul>
	Liquid level drops immediately when pump is primed		<ul style="list-style-type: none"> <li>Foot valve is clogged with foreign matter</li> </ul>	<ul style="list-style-type: none"> <li>Replace strainer.</li> <li>Check if set is clogged with foreign matter.</li> </ul>
Liquid is not pumped	Liquid level drops if discharge valve is opened after starting pump	Pressure & vacuum gauge needles move but return immediately to zero	<ul style="list-style-type: none"> <li>Air enters through suction pipe or gasket section</li> <li>Magnet coupling is disconnected</li> <li>RPM of pump is insufficient</li> <li>Pump rotation is reversed,</li> </ul>	<ul style="list-style-type: none"> <li>Make sure connection flange in suction piping is sealed airtight.</li> <li>Is suction liquid level abnormally low?</li> <li>Stop pump, use screwdriver to check for easy &amp; smooth rotation of motor fan.</li> <li>Measure current level for low reading</li> <li>Check inside pump cavity for foreign matter.</li> <li>Check if voltage level is normal.</li> <li>Replace drive magnet and/or magnet capsule.</li> <li>Check wiring &amp; motor and fix as necessary.</li> <li>Correct motor wiring.</li> </ul>
Discharge quantity is small	Pressure & Vacuum gauges indicate normal values	Vacuum gauge indicates high value	<ul style="list-style-type: none"> <li>Strainer is clogged with foreign matter, blocking liquid flow</li> </ul>	<ul style="list-style-type: none"> <li>Remove foreign matter in strainer.</li> </ul>
		Vacuum gauge indicates abnormally high value	<ul style="list-style-type: none"> <li>Air is trapped in suction pipe</li> <li>Inlet section of impeller unit is clogged with foreign matter</li> </ul>	<ul style="list-style-type: none"> <li>Inspect suction pipe and modify installation as necessary.</li> <li>Partially disassemble unit and remove foreign matter.</li> </ul>
		Pressure & Vacuum gauges fluctuate	<ul style="list-style-type: none"> <li>Air entering via suction pipe or gasket section</li> <li>Discharge side of pump is clogged with foreign matter</li> </ul>	<ul style="list-style-type: none"> <li>Check flange gaskets of suction pipe &amp; tighten</li> <li>Remove foreign matter in pump or scale inside of piping.</li> </ul>
		Vacuum gauge indicates high value while pressure gauge is normal	<ul style="list-style-type: none"> <li>Air pocket or resistance in suction pipe</li> </ul>	<ul style="list-style-type: none"> <li>Inspect suction piping installation and make corrective adjustments</li> </ul>
		Pressure gauge indicates high value while vacuum gauge is normal	<ul style="list-style-type: none"> <li>Discharge pipe section causing high resistance or actual head and loss of head is too high</li> </ul>	<ul style="list-style-type: none"> <li>Check actual head &amp; loss of discharge in pipe.</li> </ul>

Trouble	Symptom on Pump		Cause	Inspection & Countermeasures
	With discharge valve closed	With discharge valve open		
Discharge quantity is too low.	Pressure gauge indicates low value while vacuum gauge is extremely low.	Pressure gauge and vacuum gauge indicate low values	<ul style="list-style-type: none"> <li>Rotating direction of pump/motor is reversed.</li> </ul>	<ul style="list-style-type: none"> <li>Correct motor wiring to reverse rotation. (clockwise when viewed from motor side)</li> </ul>
Motor overheats.			<ul style="list-style-type: none"> <li>Insufficient voltage</li> <li>Overload</li> <li>Ambient temperature is high.</li> </ul>	<ul style="list-style-type: none"> <li>Make sure voltage &amp; frequency levels are adequate.</li> <li>Check specific gravity &amp; viscosity of liquid.</li> <li>Stop pump, use screwdriver to make sure motor fan rotates easily &amp; smoothly.</li> <li>Improve air ventilation.</li> </ul>
Discharge quantity is suddenly lowered		Vacuum gauge indicates high value	<ul style="list-style-type: none"> <li>Strainer is clogged with foreign matter, blocking liquid flow.</li> </ul>	<ul style="list-style-type: none"> <li>Remove foreign matter in strainer.</li> </ul>
Pump vibrates			<ul style="list-style-type: none"> <li>Foundation is inadequate.</li> <li>Anchor bolt is loose.</li> <li>Cavitation from closed or restricted suction pipe.</li> <li>Wear or melting of pump bushing.</li> <li>Damaged inner magnet assembly or pump spindle.</li> <li>Fluctuating dynamic balance of outer drive magnet assembly.</li> <li>Wear of motor bearing.</li> </ul>	<ul style="list-style-type: none"> <li>Check installation process again.</li> <li>Re-tighten bolt.</li> <li>Clean, eliminate cause of cavitation.</li> <li>Replace.</li> <li>Replace.</li> <li>Remove or replace.</li> <li>Replace bearing or motor.</li> </ul>

## 9 Parts Description and Exploded View

MX-250 - 401

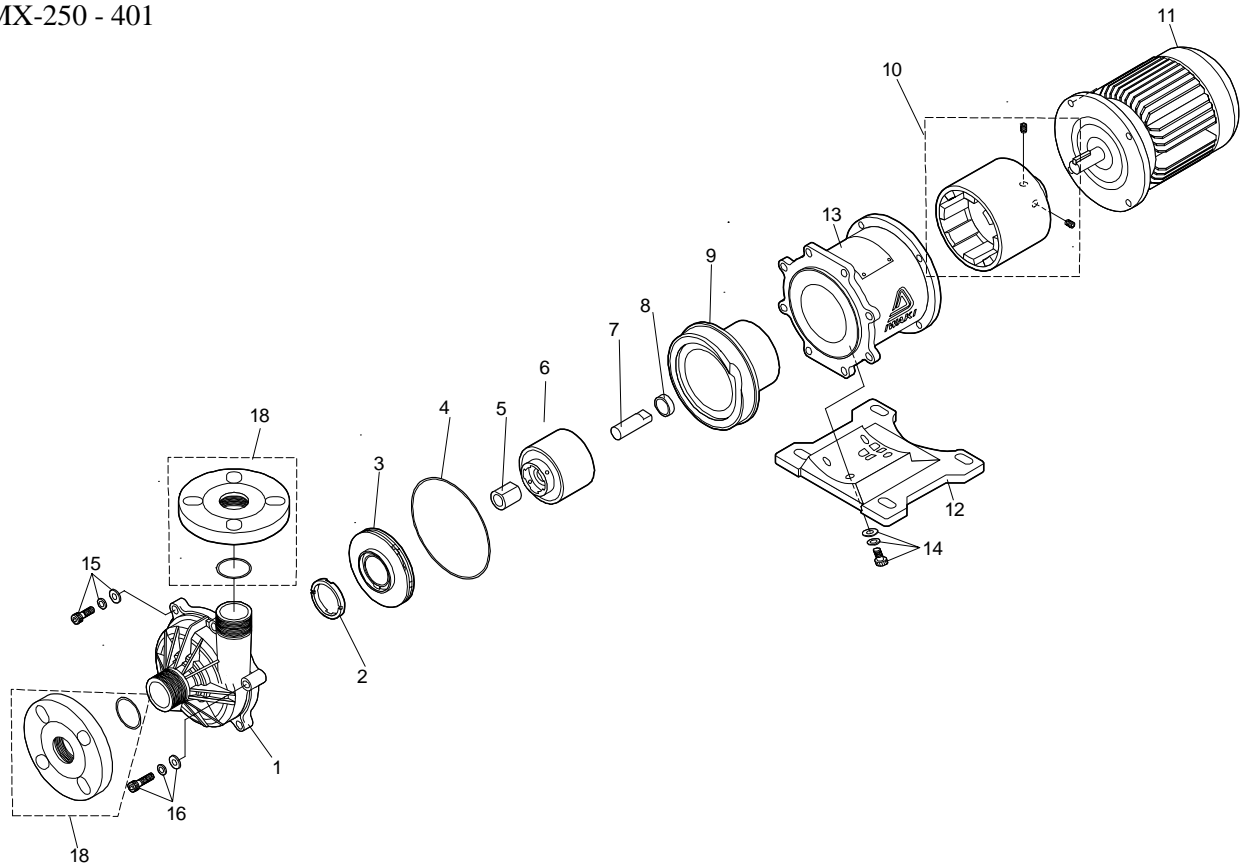

Fig. 9

No.	Description	Qty	No.	Description	Qty
1	Front casing	1	10	Drive magnet	1
2	Mouth ring	1	11	Motor	1
3	Impeller	1	12	Baseplate	1
4	O-ring	1	13	Motor adapter	1
5	Bearing	1	14	Bolt, baseplate w/PW & SW	4
6	Magnet capsule	1	15	Bolt, front casing w/PW & SW	6
7	Shaft	1	16	Bolt, front casing w/PW & SW	2
8	Thrust collar	1	18	Flange kit	2
9	Rear casing	1			

MX-402 – 403(H)

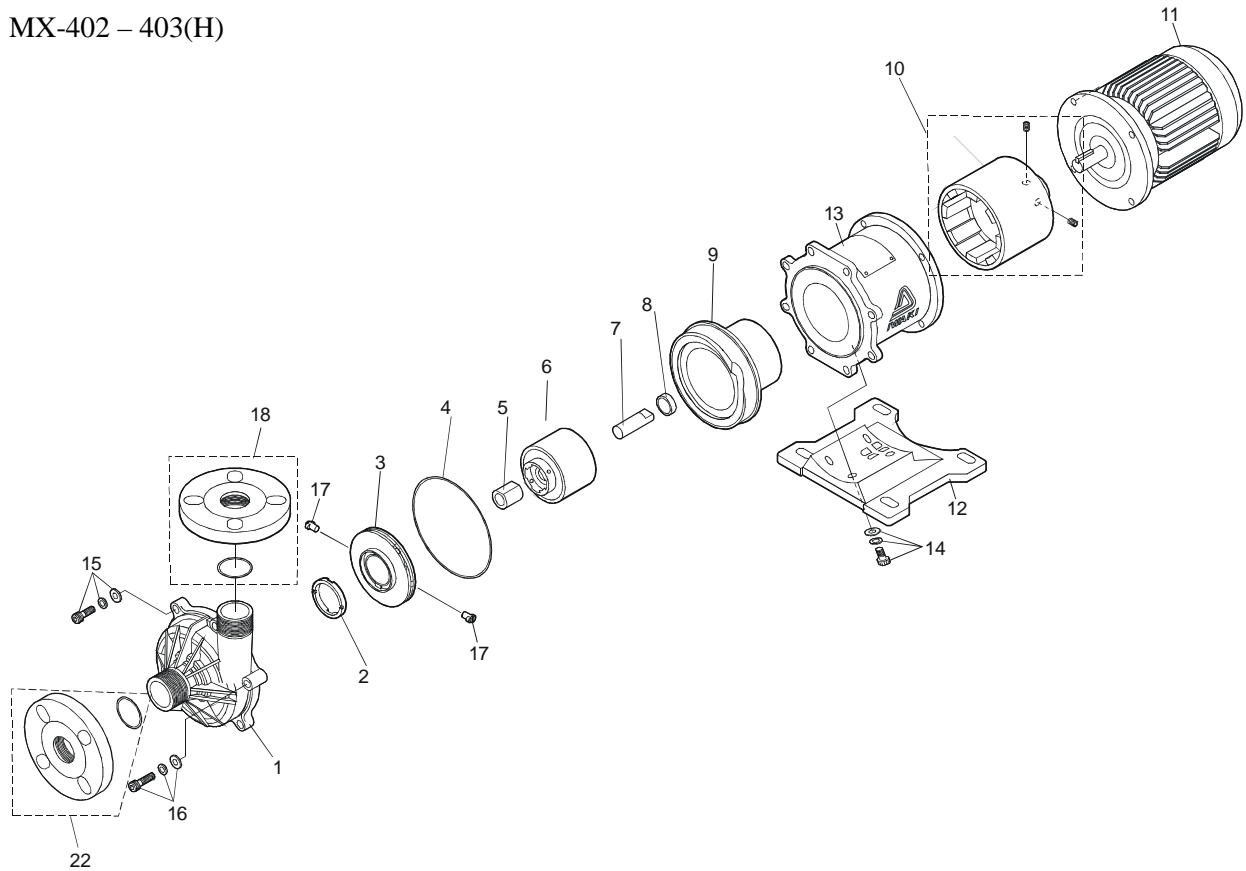

Figure 10

No.	Description	Qty	No.	Description	Qty
1	Front casing	1	11	Motor	1
2	Mouth ring	1	12	Baseplate	1
3	Impeller	1	13	Motor adapter	1
4	O-ring	1	14	Bolt, baseplate w/PW & SW	4
5	Bearing	1	15	Bolt, front casing w/PW & SW	6
6	Magnet capsule	1	16	Bolt, front casing w/PW & SW	2
7	Shaft	1	17	Impeller lock pin	2
8	Thrust collar	1	18	Flange kit, discharge	2
9	Rear casing	1	22	Flange kit, suction	1
10	Drive magnet	1			

## 10 Disassembly and Assembly of Pump



### Caution!

Since the magnets used in the pump are powerful, be careful not to catch your fingers or hand between them during disassembly or assembly. Also, keep the magnet unit away from any electronic device (or ATM card with a magnetic strip) that could be affected by a strong magnetic field.

Prior to servicing, the suction and discharge valves must be closed. The piping and the pump often retain some liquid. It is recommended the piping and pump cavity be drained prior to servicing.

If dangerous liquid is used, wear protection and flush pump with clean water or decontaminant prior to service.

Make sure power to the motor is off.

### ■ Disassembly

1. Loosen hex socket head bolts to remove front casing from motor bracket. Drain residual liquid from the casing and clean.
2. Pull out impeller and magnet capsule. (Be careful not to pinch fingers).
3. When removing the impeller from the magnet capsule:

- **For MX-250 to 401**

Hold the magnet capsule and slightly tap the back side of the impeller with a plastic hammer. If the impeller doesn't slide out easily, place them in hot water (approx. 90°C) for 5 minutes.

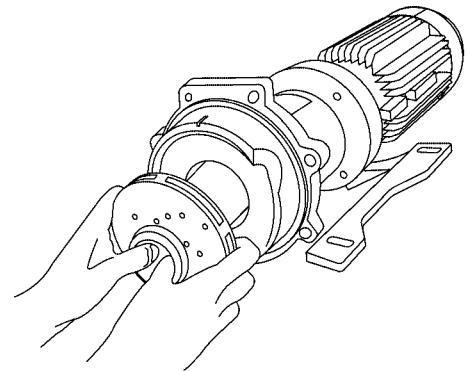
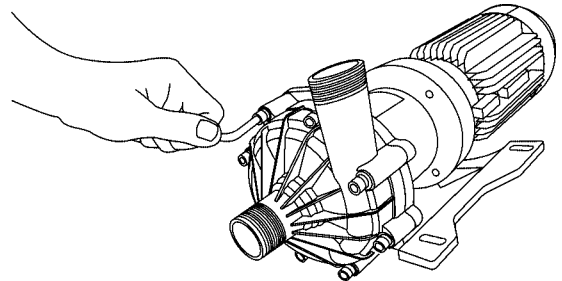

- **For MX-402(H) and 403(H)**

Turn the lock pin counter clockwise direction by 90 degrees using a slotted screw driver and then push it towards the inside of the impeller. If it is hard to push it out, slightly tap the end of driver handle. If the screw driver can not be used because the groove of pin was crushed, turn the pin from inside of magnet capsule using hex. wrench. In this case pay attention to turn the wrench clockwise. The lock pin will be damaged if it is turned in reverse direction. After the pin is turned, push it in from the outside using a screwdriver or drive pin.

After the two lock pins are removed, remove the impeller from the magnet capsule by slightly tapping the periphery of impeller with plastic hammer. If it is hard to remove, warm it with hot water (approx. 90deg. C) for five minutes and remove it by slightly tapping it as above. Pay attention not to burn yourself. Impeller cannot be separated from magnet capsule unless lock pin is removed. These parts will break if the impeller is removed by force.

4. To remove a rear casing, insert a slotted screwdriver to the periphery of rear casing and slightly twist the screwdriver. Pay attention not to damage the o-ring.

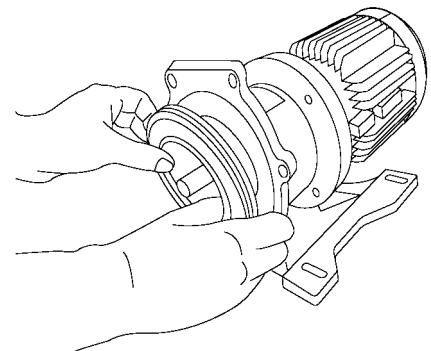
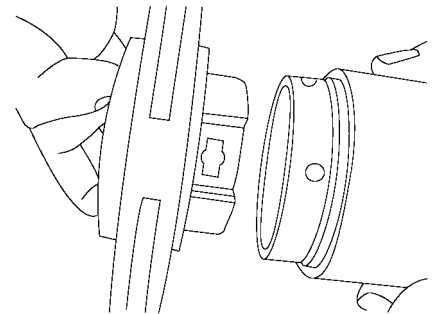
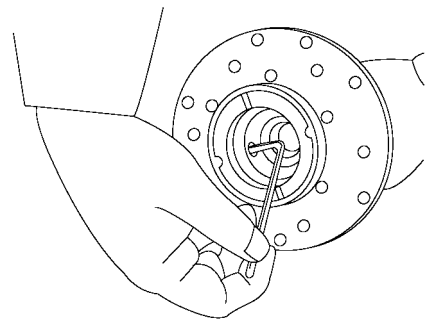
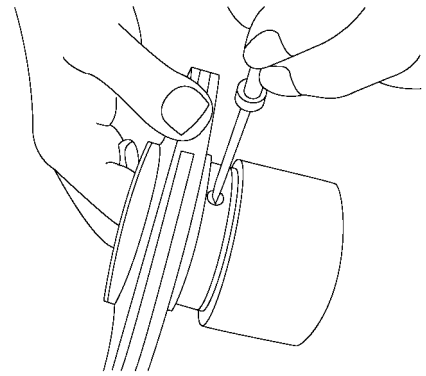

## ■ Reassembly

Reassemble the pump by reversing the order of disassembly. Take care not to contaminate or damage the seal faces or o-rings. Tighten the bolts uniformly to prevent uneven tightening.

1. Mount the motor adapter to the motor. Depending on the pump model, the base may need to be removed for proper installation. Secure the motor adapter to the motor with the proper hardware.

Note: A lock washer may not fit on all models.

2. Place the drive magnet onto the motor shaft with two set screws.

- **For MX-(F) 250 to 401 models**

Adjust the position of the drive magnet on the motor shaft so it measures 0.157" below the face of the motor adapter (see figure). After the magnet height is set correctly, tighten the two set screws to secure the magnet on to the motor shaft.

- **For MX-(F) 402 to 403(H) models**

Adjust the position of the drive magnet on the motor shaft so it measures 0.354" below the face of the motor adapter (see figure). After the magnet height is set correctly, tighten the two set screws to secure the magnet on to the motor shaft.

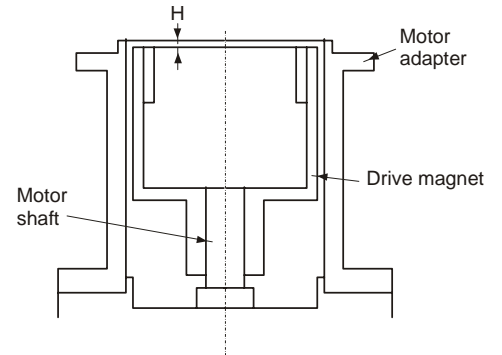

3. Mount the impeller to the magnet capsule.

- **For MX-250 to 401 models**

Fit the projected and recessed parts of magnet capsule and impeller together and push the impeller to the bottom. Put the thru hole on the magnet capsule and U shaped hole of impeller together. If there is no gap between the end surface of the impeller and bearing end surface, this means the impeller was installed correctly. If it is hard to press fit them, warm the magnet capsule only by putting it in hot water (approx. 90 deg. C) for five minutes.

- **For MX-402(H) and 403(H) models**

The mating part of the magnet capsule has two holes. The larger hole is for the lock pin (stepped hole on the outside is 6 mm dia and the inside is 12mm dia) and a smaller hole (3mm dia.) is for cooling purposes. The U-shaped hole of the impeller and smaller hole (3 mm dia) of magnet capsule are also for cooling purposes. Insert the impeller into the magnet capsule slowly by positioning the two holes together. If it is hard to insert them, warm the magnet capsule only with hot water (approx. 90 deg. C) for five minutes.

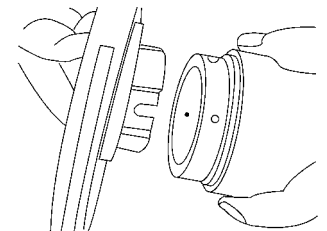
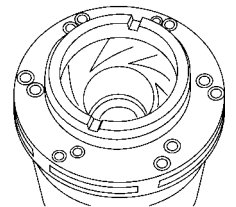
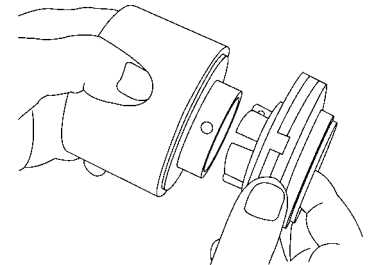

After the impeller is inserted (press-fit), insert the lock pins from the inside and then tighten the pin by turning it clockwise 90 degrees from outside with a slotted screwdriver. You will feel a snap when it is fixed securely.

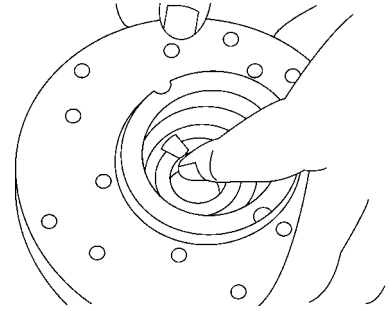

If the groove for a slotted screwdriver is deformed and cannot be used, the pin can be locked from the inside with a 4mm hex. wrench. In this case, turn the wrench counter clockwise. The lock pin may be broken if it is turned in reverse.

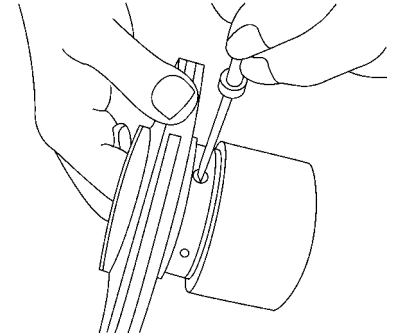

4. Make sure no iron pieces or other foreign matters do not adhere to the magnet capsule. Put the magnet capsule with impeller into the rear casing slowly.

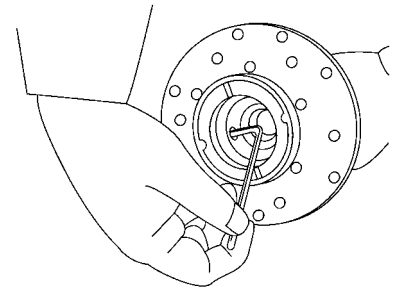

5. Mount the rear casing with magnet capsule to the motor adapter.

### Caution

Magnet force is very strong. Apply plastic or wooden spacers between the rear casing and bracket to absorb any slack. Be careful not to pinch your fingers.

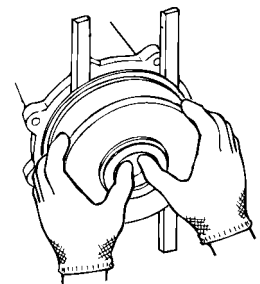

6. Put the o-ring inside the front casing. Make sure there is no dust or cuts on it. For MX-250, 251 and 401 models the recessed and projected portions of rear casing and front casing fit together. Note that there are two recesses on the rear casing and two projections on front casing on the MX-(F)402(H) and (F)403(H) models.

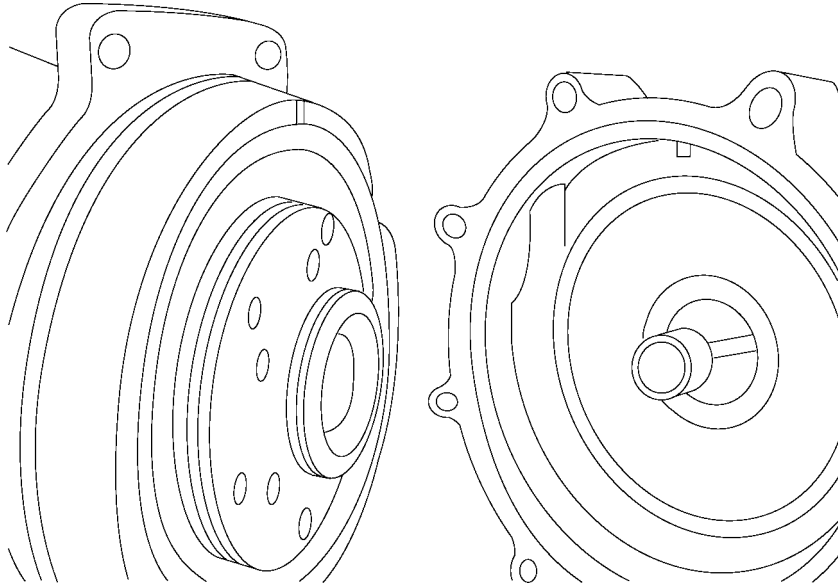

7. Mount the front casing to the motor adapter.  
Tighten the mounting bolts diagonally and evenly. Tightening torque is shown below.

Model	Bolt tightening torque
MX-(F)250, 251, (F)400, (F)401	8.7 ft. lbs. (11.8 N-m)
MX-(F)402, 402(H), (F)403, 403(H)	10.8 ft. lbs (14.7 N-m)

## 11 Spare Parts

Original factory spare parts are necessary to ensure continuous pump operation. Expendable parts, such as bearings, spindles and mouth (thrust) rings should always be kept on hand. Consult your distributor or Iwaki Walchem for the correct part numbers and pricing. When placing orders, supply the following information.

1. Description and item number (according to this instruction manual).
2. Pump model number and serial number (as shown on the nameplate of the pump).
3. Drawing number if you have received a certified drawing.

## 12 Weights and Dimensions

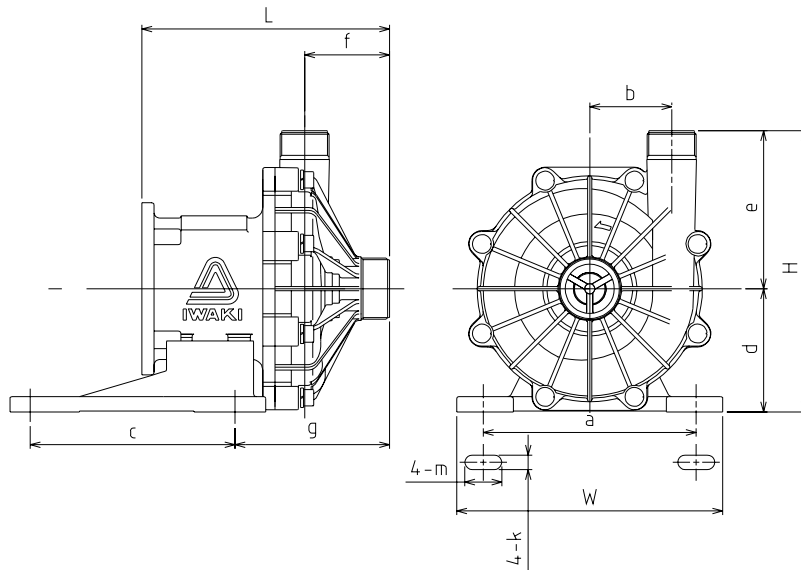

Note 1: Overall length varies with motor type and manufacturer.  
Dimensions in inches (mm)

MODEL SERIES	W	H	L	a	b	c	d	e	f	g	k	m
MX-250	6.30 (160)	9.75 (248)	9.39 (239)	5.12 (130)	2.56 (65)	5.12 (130)	4.53 (115)	5.22 (133)	3.25 (83)	6.12 (155)	.47 (12)	----
MX-251					3.00 (76)							6.44 (164)
MX-400	5.51 (140)	8.62 (219)	9.37 (238)	4.33 (110)	2.13 (54)	3.86 (98)	3.74 (95)	4.88 (124)	3.19 (81)	5.67 (144)		----
MX-401	6.30 (160)	9.81 (249)	9.96 (253)	5.12 (130)	2.83 (72)	5.12 (130)	4.53 (115)	5.28 (134)	3.82 (97)	7.01 (178)		----
MX-(F)402(H) MX-(F)403(H)	10.24 (260)	10.78 (274)	9.53 (242)	8.19 (208)	3.15 (80)	7.87 (200)	4.72 (120)	6.06 (154)	3.27 (83)	5.94 (151)	.55 (14)	1.42 (36)

---

Iwaki Walchem Corporation  
5 Boynton Road Hopping Brook Park Holliston, MA 01746 USA  
TEL: 508-429-1440 FAX: 508-429-1386 [www.iwakiwalchem.com](http://www.iwakiwalchem.com)