

# Diversa-Flow Krystil Klear Division

## Liquid BAG HOUSINGS

Diversa-Flow Liquid Bag Housings give you the capability of a continuous flow for non-stop filtering during maintenance, offering an economical alternative to multi-round duplexing. Diversa-Flow systems effectively remove dirt, pipe scale, and other contaminants from process liquids. They provide a wide variety of choices for flow rates and particulate removal. Plus, quality construction and design assure clean effluent and protection for all downstream equipment.

### APPLICATIONS

- Chemical
- Oil and Gas
- General Industrial
- Water



### HOUSING OPERATIONS

An optional automatic actuation system can be added to all housings for ease of operation. The automated system will switch flow between the housings after reaching a programmed differential pressure.

### HOUSING OPTIONS

- Mesh-lined strainer baskets
- Alternative o-ring materials
- Adjustable support legs
- Automatic or manual switching system
- ASME code U or UM

### FEATURES

- Flow rates up to 200 gpm per housing
- Housings with common connections
- Continuous flow rates
- Independent serviceability
- Large sump area at the bottom of the basket for dirt and scale accumulation
- Carbon or Stainless Steel construction
- Each vessel is factory hydro-tested
- Quick-swing closure with eye nuts
- Viton® seals — lid and basket
- Differential, drain, and vent ports
- Structural stand
- 316 Stainless Steel strainer baskets

### SPECIFICATIONS

Model	Maximum Dimensions
Pressure Rating	150 PSI
Connections	NPT or RF FLG
Housing Lid	3-bolt swing closure with vent port
Lid & Basket Seals	Viton® o-ring
Pressure Ports	Two 0.25-inch NPT
Construction/Finish	Carbon steel w/two-part epoxy finish; 304 or 316 Stainless Steel w/satin finish
Basket Material	316 Stainless Steel with 9/64-inch perforations



**Pentair  
Industrial**

## ORDERING INFORMATION

Custom configurations available; please contact Customer Service.

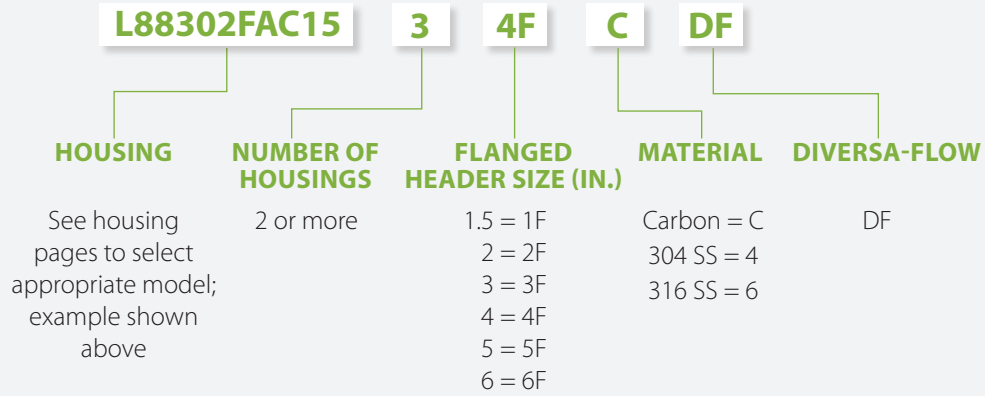

## DIMENSIONS

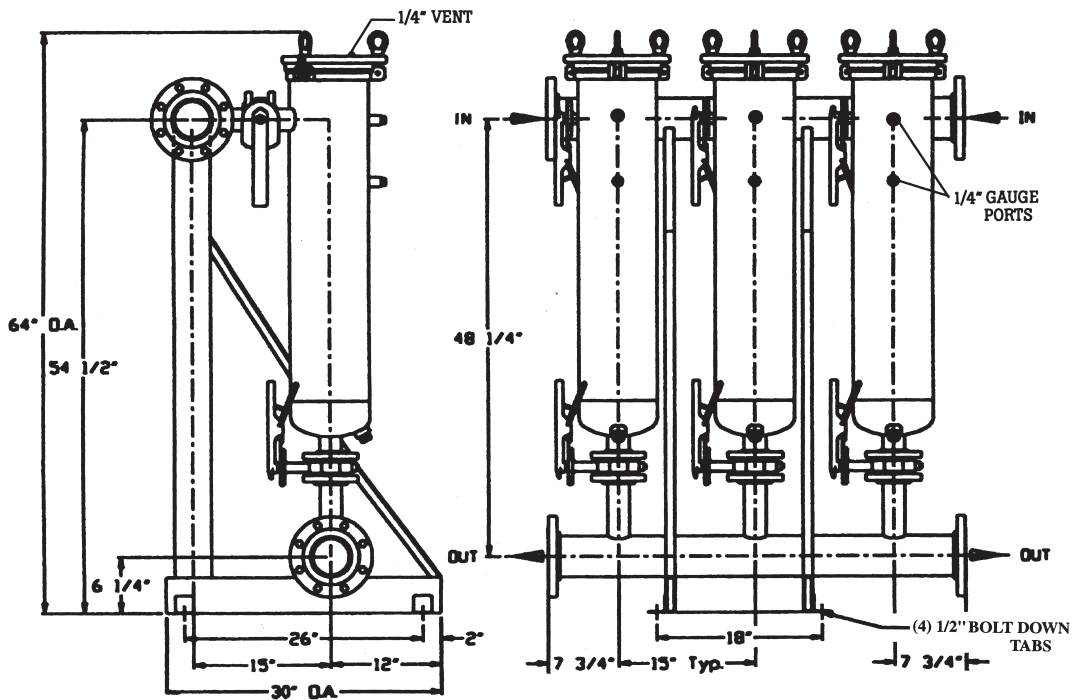

All dimensions are approximate.



Distributed by: KTH Sales, Inc, Merrillville, IN  
 Phone 219-736-0060 FAX 219-769-0263  
 sales@KTHSales.com www.KTHSales.com