



Duplex

Krystil Klear Division

Liquid BAG HOUSINGS

Duplex Liquid Bag Housings offer the capability of a continual flow for non-stop filtering during maintenance. Duplex systems effectively remove dirt, pipe, scale, and other contaminants from process liquids, and they deliver a wide variety of choices for flow rates and particulate removal. Plus, quality construction and design assure clean effluent and protection for all downstream equipment.

APPLICATIONS

- Chemical
- General Industrial
- Oil and Gas
- Water

HOUSING OPERATIONS

An optional automatic actuation system can be added to all housings for ease of operation. The automated system will switch flow between the housings after reaching a programmed differential pressure.

HOUSING OPTIONS

- Mesh-lined strainer baskets
- Alternative seal materials
- Adjustable support legs
- Automatic or manual switching system
- ASME code U or UM

FEATURES

- Twin housings with common connections
- Continuous flow possible
- Single handle actuation to switch between housings (4-inch piping and smaller) or independent controls (6-inch and larger)
- Carbon steel or Stainless Steel construction
- Each vessel is factory hydro-tested
- Quick-swing closure with eye nuts
- O-ring seals — lid & basket
- Differential, drain, and vent ports
- 316 Stainless Steel strainer baskets

SPECIFICATIONS

Pressure Rating	150 PSI at 300° F (up to 500 PSI optional)
Connections	NPT or RF FLG
Flow Switching	Single handle (4-inch piping and lower) or independent controls (6-inch and larger)
Housing Lid	Swing closure with vent port
Lid & Basket Seals	O-ring (material dependent on model)
Pressure Ports	Two 0.25-inch NPT
Construction/Finish	Carbon steel w/two-part epoxy finish; 304 or 316 Stainless Steel w/satin finish
Basket Material	316 Stainless Steel with 9/64-inch perforations



**Pentair
Industrial**

ORDERING INFORMATION

Custom configurations available; please contact Customer Service.

	LR3	9	3	F	B	C	15	D
HOUSING	BASKET SIZE (IN.)	CONNECTION SIZE (IN.)	CONNECTION TYPE	OUTLET LOCATION	MATERIAL	PRESSURE RATING (PSI)	ACTUATION	
L44, L66	1	0.75	Flange = F	Side = B	Carbon=C	150 = 15	Manual = D	
L88, LR2	2	1			304 SS=4	300 = 30	Auto Actuated	
LR3, LR4	3	2			316 SS=6	500 = 50	System = DA	
LR6, LR8	4	3						
LR12, LR17	8	4						
LR21	9	6						
		8						
		10						
		12						

DIMENSIONS

Single Housing

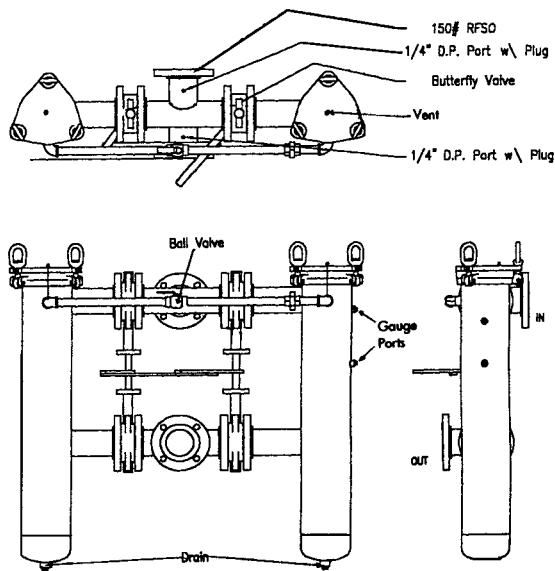

Multi-Round Housing

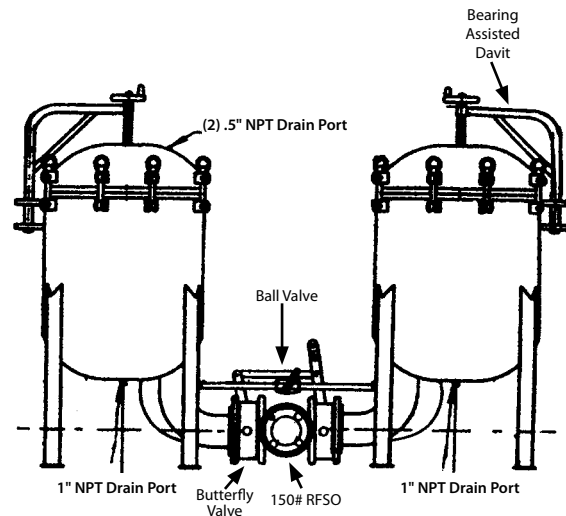

Distributed by: KTH Sales, Inc. Merrillville, IN
 Phone 219-736-0060 FAX 219-769-0263
 sales@KTHSales.com www.KTHSales.com