



## L88

## Krystil Klear Division

### 100 PSI Single Liquid BAG HOUSINGS

L88 100 PSI Liquid Bag Housings offer quality vessels for lower pressure applications and effectively remove dirt, pipe scale, and other contaminants from process liquids. Quality construction and design assure clean effluent and protection for all downstream equipment.

#### APPLICATIONS

- Chemical
- General Industrial
- Oil and Gas
- Water

#### HOUSING OPERATION

Unfiltered liquid enters the housing above the filter bag or strainer basket; fills the interior of the housing; and continues through the bag or strainer basket. Solids are trapped inside the filter bag or strainer and easily removed when the housing is serviced. The standard o-ring seal between the basket and the housing ensures a positive seal to prevent bypass.

#### HOUSING OPTIONS

- Mesh-lined strainer baskets
- Alternative o-ring materials
- Adjustable support legs
- ASME code U or UM

#### FEATURES

- Flow rates up to 220 gpm
- Carbon steel or 304 Stainless Steel construction
- Each vessel is factory hydro-tested
- Low pressure drop
- Quick-swing closure with eye nuts
- Buna-N® seals — lid & basket
- Differential, drain, and vent ports
- 304 Stainless Steel strainer basket
- 2-inch female NPT connection
- Accepts #1-size and #2-size bag filters

#### SPECIFICATIONS

Pressure Rating	100 PSI at 300° F (up to 300 PSI optional)
Connections	2-inch (NPT)
Housing Lid	3-bolt swing closure with 0.25-inch NPT vent port
Lid & Basket Seat	Buna-N® o-ring in the basket support
Inlets/Outlets	Side inlet/bottom outlet; side inlet/side outlet; side inlet/90° bottom outlet
Pressure Ports	Two 0.25-inch NPT
Construction/Finish	Carbon steel w/two-part epoxy finish; 304 or 316 Stainless Steel w/satin finish
Basket Material	304 Stainless Steel with 9/64-inch perforations
Bags Sizes	#1 and #2 liquid bags accepted
Base	Adjustable tripod leg assembly



**Pentair  
Industrial**

# L88, 100 PSI Single Bag Housings

Krystil Klear Division

## ORDERING INFORMATION

Custom configurations available; please contact Customer Service.

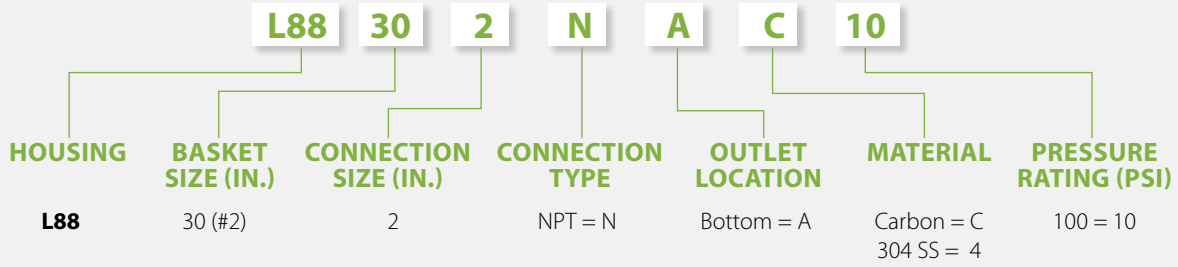

## DIMENSIONS

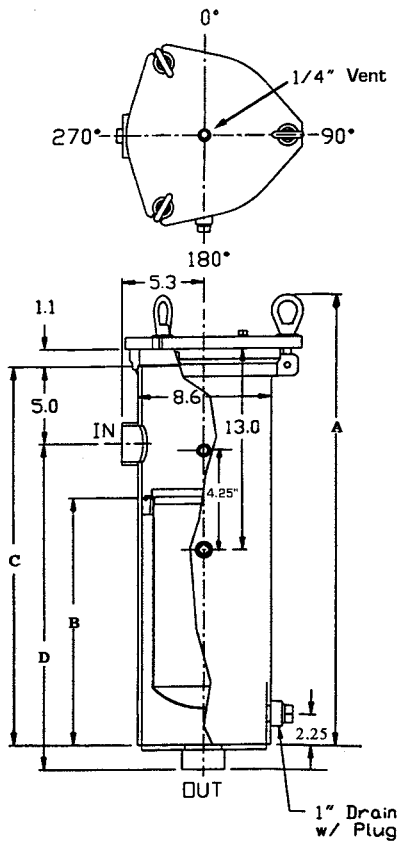

All dimensions are approximate.

## BASKET DATA

	30 (in.)
A	42.1
B	27.5
C	36.0
D	32.6



Distributed by: KTH Sales, Inc. Merrillville, IN  
 Phone 219-736-0060 FAX 219-769-0263  
 sales@KTHSales.com www.KTHSales.com