

Series "FC" Flow Control Valves 1/4" – 3"

FEATURES:

- Maintain constant flow with inlet pressure changes from 15 to 120 PSI (1 Bar to 8 Bars)
- For corrosive and ultra pure liquid applications
- No metals in contact with the liquid
- Standard flow ranges from 1/4 GPM to 120 GPM
- Automatic in operation - no adjustments

IMPORTANT:

These flow controls are designed for liquids similar in viscosity to water. All applications should be tested for flow characteristics and chemical compatibility to insure desired results. Swelling of the diaphragms in certain liquids will result in loss of flow rate accuracy. An in-line strainer or filter should be installed before the flow control when suspended solids are present, and for all applications below 1.0 GPM (3.8 LPM).

ACCURACY: The rated output of Series "FC" flow controls will vary $\pm 10\%$ with Buna-N assemblies and $\pm 15\%$ with EPDM assemblies.

MATERIALS OF CONSTRUCTION:

The standard Series "FC" flow controls are constructed of TYPE 1, GRADE 1 PVC (Polyvinyl Chloride) with diaphragms of either Buna-N or EPDM. Stainless steel fasteners are standard. Bodies are also available in virgin polypropylene, Teflon®, and Kynar®. Consult factory.

OPERATION AND INSTALLATION:

The Series "FC" flow controls are used to maintain a constant pre-determined flow in a system. They must be installed in the correct flow direction (indicated by label) to work properly. They utilize a diaphragm which changes shape with inlet pressure changes, thus maintaining a constant flow rate. They are normally used to replace more costly flow control devices. Standard flow ranges are from 1/4 GPM to 120 GPM (.95 LPM to 454 LPM). The minimum pressure drop needed across the flow control is 15 PSI (1 Bar) in order to get the desired flow.

TEMPERATURE AND PRESSURE:

The Series "FC" flow controls can operate from 40°F – 140°F (5°C – 60°C) with PVC bodies and either Buna-N or EPDM diaphragms. With optional polypropylene,

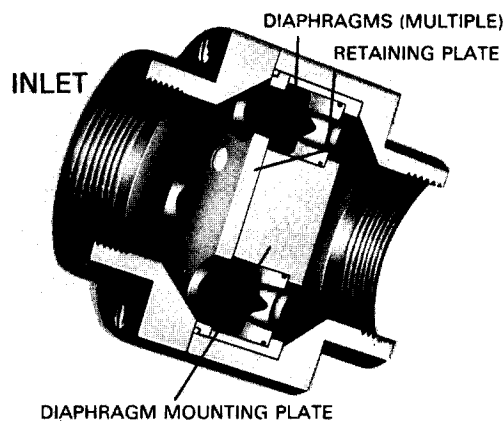
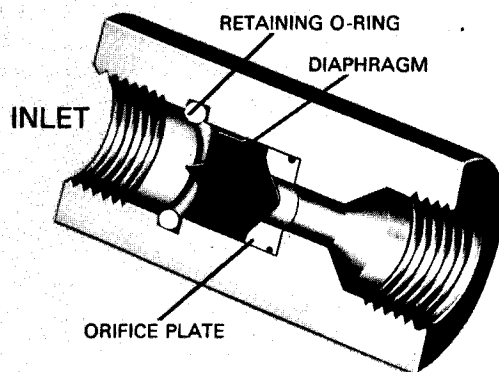

Teflon, or Kynar bodies they can operate from 40°F – 180°F (5°C – 82°C) with EPDM diaphragms, and 40°F – 160°F (5°C – 71°C) with Buna-N diaphragms. The Series "FC" flow controls must have at least 15 PSI (1 Bar) pressure drop across the control in order to deliver the rated flow. Maximum pressure is 120 PSI (8 Bars). See temperature vs pressure chart on reverse side.

Series "FC" Flow Control Valves

ORDERING INFORMATION:

Order by part number as follows: The basic number is given in the chart below, follow it with either "B" or "EP" for Buna-N or EPDM seals respectively. This is then to be followed by the required flow rate. FOR EXAMPLE: a 3/8" NPT control with EPDM seals having

a 1/2 GPM flow rate is part number FC037EP-1/2-PV. Specify exact chemicals, pressures, and temperatures. For body materials other than PVC please contact our Sales Department. Standard threads are NPT. For BSP threads be sure to specify on order.

SERIES "FC" PIPE SIZE			1/4"		3/8"		1/2"		3/4"	
BASIC PART NUMBERS			FC025		FC037		FC050		FC075	
Flow Rate Gal/Min	Flow Rate Liters/Min	Number of Control Ass'y In Housing	Overall Length in mm	Diameter in mm	Overall Length in mm	Diameter in mm	Overall Length in mm	Diameter in mm	Overall Length in mm	Max. Diameter in mm
1/4	.95	1	2 3/8 60.3	1 1/8 28.6	2 1/8 54.0	1 1/8 28.6	2 1/2 63.5	1 1/4 31.8		
1/2	1.9	1	2 3/8 60.3	1 1/8 28.6	2 1/8 54.0	1 1/8 28.6	2 1/2 63.5	1 1/4 31.8		
3/4	2.8	1	2 3/8 60.3	1 1/8 28.6	2 1/8 54.0	1 1/8 28.6	2 1/2 63.5	1 1/4 31.8		
1	3.8	1	2 3/8 60.3	1 1/8 28.6	2 1/8 54.0	1 1/8 28.6	2 1/2 63.5	1 1/4 31.8		
1 1/2	5.7	1	2 3/8 60.3	1 1/8 28.6	2 1/8 54.0	1 1/8 28.6	2 1/2 63.5	1 1/4 31.8		
2	7.6	1	2 3/8 60.3	1 1/8 28.6	2 1/8 54.0	1 1/8 28.6	2 1/2 63.5	1 1/4 31.8		
3	11	1							3 1/4 82.5	1 1/2 38.1
4	15	1							3 1/4 82.5	1 1/2 38.1
5	19	1							3 1/4 82.5	1 1/2 38.1
6	23	1							3 1/4 82.5	1 1/2 38.1
7	26	1							3 1/4 82.5	1 1/2 38.1
8	30	1							3 1/4 82.5	1 1/2 38.1
9-16	34-61	2							5 127.0	3 1/2 88.9
17-24	64-91	3							5 127.0	3 1/2 88.9

SERIES "FC" PIPE SIZE			1"		1 1/4"		1 1/2"		2"	
BASIC PART NUMBERS			FC100		FC125		FC150		FC200	
Flow Rate Gal/Min	Flow Rate Liters/Min	Number of Control Ass'y In Housing	Overall Length in mm	Max. Diameter in mm	Overall Length in mm	Max. Diameter in mm	Overall Length in mm	Max. Diameter in mm	Overall Length in mm	Max. Diameter in mm
5	19	1	3 1/2 88.9	2 50.8						
6	23	1	3 1/2 88.9	2 50.8						
7	26	1	3 1/2 88.9	2 50.8						
8	30	1	3 1/2 88.9	2 50.8						
9-16	34-61	2	5 127.0	3 1/2 88.9	5 127.0	3 1/2 88.9				
17-24	64-91	3	5 127.0	3 1/2 88.9	5 127.0	3 1/2 88.9				
25-32	95-121	4			5 1/4 133.3	4 101.6	5 1/4 133.3	4 101.6		
33-40	125-151	5			5 1/4 133.3	4 101.6	5 1/4 133.3	4 101.6		
41-64	155-242	8					6 1/8 155.6	4 1/2 114.3	6 1/8 155.6	4 1/2 114.3
65-96	246-363	12							7 1/4 184.2	5 1/2 139.7
97-120	367-454	15							7 1/4 184.2	5 1/2 139.7

SERIES "FC" PIPE SIZE			3"	
BASIC PART NUMBERS			FC300	
Flow Rate Gal/Min	Flow Rate Liters/Min	Number of Control Ass'y In Housing	Overall Length in mm	Max. Diameter in mm
5	19	1		
6	23	1		
7	26	1		
8	30	1		
9-16	34-61	2		
17-24	64-91	3		
25-32	95-121	4		
33-40	125-151	5		
41-64	155-242	8		
65-96	246-363	12	7 1/4 184.2	5 1/2 139.7
97-120	367-454	15	7 1/4 184.2	5 1/2 139.7

MATERIALS TEMPERATURE vs PRESSURE									
Max. Inlet Temperature vs Pressure									
Mat'l	Max. Temp Rating	75°F PSI	24°C BARS	110°F PSI	43°C BARS	140°F PSI	60°C BARS	180°F PSI	82°C BARS
PVC	140°F 60°C	120	8	90	6	30	2	N.R.	N.R.
PP	180°F 82°C	120	8	90	6	60	4	30	2
Teflon	180°F 82°C	120	8	120	8	90	6	90	6
Kynar	180°F 82°C	120	8	120	8	90	6	90	6

Important: For flows above 9 GPM (34 l/m) up to 120 GPM (454 l/m) specify exact flow rate (and not the flow range) desired, in increments of 1 GPM. e.g. to order a 1" PVC valve with Buna-N seals and a desired flow rate of 12 GPM, the correct model number is FC100EP-12-PV.



AUTHORIZED PLAST-O-MATIC DISTRIBUTOR

