



## SERIES EASYM AND EASM – U-CUP DESIGN

**Application:** Series EASYM and EASM solenoid valves automatically shut off flow of highly corrosive or ultra pure liquids. They can handle pressure, drain, or vacuum applications and do not require pressure to aid in opening the valve. The patented Fail-Dry® vented design with a secondary backup diaphragm helps to avoid emergency shutdowns and gives a visual warning of potential problems.

**Design and Operation:** Valves are spring return normally closed and direct acting with a simple push-pull plunger design. There is no minimum pressure required for operation. Multiple U-cups are mounted around a PTFE shaft for low friction sealing, non-sticking operation, and million-cycle design. The multiple U-cup design also allows a stock valve to be used for vacuum or pressure. A poppet seat insures bubble-tight shutoff.



**Fail-Dry® Patented Vent:** In the event of a valve failure and the subsequent leakage past the primary seals (U-cups), a secondary flat diaphragm seal protects the metal solenoid parts from corrosion and allows the valve to continue functioning until maintenance can be scheduled. Between the primary and secondary seals is a vented chamber with a 1/8 NPT vent port. If desired, the vent can be piped to a sump area to prevent dripping and corrosion in the vicinity of the valve if leakage occurs. This is usually accomplished with 1/4 or 3/8 O.D. polypropylene tubing and a suitable tubing fitting.

**Vacuum Information:** All Series EASYM and EASM valves are rated for full vacuum of 30" of mercury except the EASM61322W20 which is rated at 15" of mercury.

### SERIES EASYM and EASM – SPECIFICATIONS AND MODEL NUMBERS

Pipe Size	Orifice Size		Watts	AC COILS				DC COILS				Viton® Seals Model Numbers††		
	In.	mm		C <sub>v</sub>	Max. Inlet Pressure		Max. Back Pressure		C <sub>v</sub>	Max. Inlet Pressure			Max. Back Pressure	
				PSI	BARs	PSI	BARs	PSI	BARs	PSI	BARs	PSI	BARs	
1/4	.280	7,1	20	1.1	140	9,5	38	2,6	1.1	70	4,8	19	1,3	EASYM2V8W20
1/2	.280	7,1	20	1.1	140	9,5	38	2,6	1.1	70	4,8	19	1,3	EASYM4V8W20
1/2	.375	9,5	20	2.1	120	8,2	18	1,2	1.6	60	4,1	18	1,2	EASM4V12W20
3/4	.500	12,7	20	3.1	40	2,7	14	0,9	2.2	20	1,4	14	1,0	EASM5V16W20
1	.656	16,7	20	5.5	12	0,8	10	0,7	4.0	6	0,4	10	0,7	EASM6V22W20
1/2	.375	9,5	58	2.3	140	9,5	38	2,6	N.A.	N.A.	N.A.	N.A.	N.A.	EASM4V12G58
3/4	.500	12,7	58	3.4	120	8,2	34	2,3	N.A.	N.A.	N.A.	N.A.	N.A.	EASM5V16G58
1	.656	16,7	58	6.2	70	4,8	34	2,3	N.A.	N.A.	N.A.	N.A.	N.A.	EASM6V22G58

**NOTES:**

1. The model numbers listed show Viton seals. For EPDM seals change "V" to "EP".
2. Model numbers are shown with "W20" (water and dust-tight NEMA 4X style coil) and "G58" (general purpose coil). For explosion-proof coils change the "W20" to "E20" and the "G58" to "E58". If a "G20" (general purpose coil) is desired, change the "W20" to "G20" and the list price is the same. Voltage must be specified with order.
3. All model numbers must be completed with body material at the end as follows: PVC with "PV", "CPVC" with "CP", Glass-filled polypropylene with "PP", and PVDF with "PF". ††
4. All valves in above chart are rated for full vacuum of 30" of mercury except EASM6B22W20 which is rated for 15" of mercury.
5. 20 watt coils are rated continuous duty. 58 watt coils are intermittent duty. See Coil Information on back page for complete details.
6. Inlet pressure rating for G20 & E20 coils are 25% less than the W20 ratings which are shown above.

## PRESSURE RATINGS FOR ALL MODELS

**Inlet Pressure:** The inlet pressure ratings in the tables are at full rated line voltage for alternating current (A.C.) or direct current (D.C.). If the line voltage is 15% lower the inlet pressure rating will be about 30% lower. If rated inlet pressures are exceeded the valve will not open and the coil could burn out.

**Back Pressure:** An important consideration in solenoid valve selection is the back pressure rating shown in the specification table. Back pressure is caused by the resistance to flow in the piping downstream of the valve. Nozzles, goosenecks, fittings, tubing, or reduced outlet

piping all create restrictions that raise the back pressure. Excessive back pressure will cause a valve to remain open when power is shut off. A second type of back pressure is that which comes from a separate pressure source downstream of the valve. This could be head pressure from a storage tank or pressure from another pump. Back pressure or downstream pressure is the most common cause of solenoid valve problems during system start-up. Therefore, sources of potential back pressure must be considered during the planning stages of a piping system.

### MATERIAL TEMPERATURE vs. PRESSURE

Material	Maximum Temperature Rating	MAXIMUM INLET PRESSURES AND TEMPERATURE													
		75°F PSI	24°C BARs	110°F PSI	43°C BARs	140°F PSI	60°C BARs	180°F PSI	82°C BARs	220°F PSI	105°C BARs	240°F PSI	116°C BARs	284°F PSI	140°C BARs
PVC	140°F (60°C)	140	9,6	100	6,8	40	2,7	N.R.	N.R.	N.R.	N.R.	N.R.	N.R.	N.R.	N.R.
CPVC or PP	180°F (82°C)	140	9,6	100	6,8	80	5,4	40	2,7	N.R.	N.R.	N.R.	N.R.	N.R.	N.R.
GPP**	220°F (105°C)	140	9,6	120	8,2	100	6,8	80	5,4	40	2,7	N.R.	N.R.	N.R.	N.R.
PTFE* or PVDF	284°F (140°C)	140	9,6	130	8,8	120	8,2	100	6,8	60	4,1	30	2,0	10	0,7

N.R. = Not Recommended. \*PP and PTFE would be fabricated valves and not molded; consult factory. \*\*GPP = Glass-filled Polypropylene for molded valves.

# SERIES EASYMD AND EASMD – ROLLING DIAPHRAGM DESIGN

**Application:** Series EASYMD and EASMD rolling diaphragm solenoid valves automatically shut off flow of mild corrosives, ultrapure liquids, caustics, and salt solutions and eliminate problems due to crystallization. The patented Fail-Dry® vented design helps to avoid emergency shutdowns with a secondary back-up diaphragm and gives a visual warning of potential problems. They are designed for pressure or drain applications only and cannot be used for vacuum. Pressure is not required to aid in opening the valve.

**Design and Operation:** Valves are spring return normally closed and direct acting with a simple push-pull plunger design. There is no minimum pressure required for operation. The miniature rolling diaphragm is capable of high pressures and more than a million cycles and does



not allow liquid or vapors to by-pass to the atmosphere. A poppet seat insures bubble-tight shutoff. They are not designed for vacuum.

**Fail Dry® Patented Vent:** In the event there is a failure of the primary seal (rolling diaphragm) resulting in leakage, a secondary flat diaphragm seal protects the metal solenoid parts from corrosion and allows the valve to continue functioning until maintenance can be scheduled. Between the primary and secondary seals is a vented chamber with a 1/8 NPT vent port. If desired, the vent can be piped to a sump area to prevent dripping and corrosion in the vicinity of the valve if leakage occurs. This is usually accomplished with 1/4 or 3/8 O.D. polypropylene tubing and a suitable tubing fitting.

**Vacuum Information:** The Series EASYMD and EASMD are not designed for vacuum.

## SERIES EASYMD and EASMD – SPECIFICATIONS AND MODEL NUMBERS

Pipe Size	Orifice Size		Watts	AC COILS				DC COILS				EPDM Seals Model Numbers††		
	In.	mm		Cv	Max. Inlet Pressure		Max. Back Pressure		Cv	Max. Inlet Pressure			Max. Back Pressure	
				PSI	BARS	PSI	BARS	PSI	BARS	PSI	BARS	PSI	BARS	
1/4	.470	11,9	20	1.1	140	9,5	34	2,3	1.1	70	4,8	17	1,1	EASYMD2EP14W20
1/2	.470	11,9	20	1.1	140	9,5	34	2,3	1.1	70	4,8	17	1,1	EASYMD4EP14W20
1/2	.470	11,9	20	2.3	120	8,2	18	1,2	1.6	60	4,1	18	1,2	EASMD4EP14W20
3/4	.500	12,7	20	3.1	60	4,1	16	1,1	2.2	30	2,1	16	1,1	EASMD5EP16W20
1	.656	16,7	20	5.5	20	1,4	12	0,8	4.0	10	0,7	12	0,8	EASMD6EP22W20
1/2	.470	11,9	58	2.3	140	9,5	34	2,3	N.A.	N.A.		N.A.	N.A.	EASMD4EP14G58
3/4	.500	12,7	58	3.1	120	8,2	30	2,0	N.A.	N.A.		N.A.	N.A.	EASMD5EP16G58
1	.656	16,7	58	5.5	70	4,8	30	2,0	N.A.	N.A.		N.A.	N.A.	EASMD6EP22G58

**NOTES:**

1. Only EPDM seals are available for this series.
2. Model numbers are shown with "W20" (water and dust tight NEMA 4X style coil) and "G58" (general purpose coil). For explosion-proof coils change the "W20" to "E20" and the "G58" to "E58". If a "G20" (general purpose coil) is desired, change the "W20" to "G20" and the list price is the same. Voltage must be specified with order.
3. All model numbers must be completed with body material at the end as follows: PVC with "PV", "CPVC" with "CP", Glass-filled polypropylene with "PP", and PVDF with "PF". ††
4. The valves in this series are not rated for vacuum.
5. 20 watt coils are rated continuous duty. 58 watt coils are intermittent duty. See Coil Information on back page for complete details.
6. Inlet pressure rating for G20 & E20 coils are 25% less than the W20 ratings which are shown above.

## DIMENSIONS FOR ALL MODELS

### A, B, AND C DIMENSIONS FOR ALL SOLENOID HOUSINGS

Pipe Size	General Purpose NEMA 1 G20			Water & Dust Proof NEMA 4X W20			Explosion Proof NEMA 7 & 9 E20			General Purpose NEMA 1 G58*			Explosion Proof NEMA 7 & 9 E58*		
	A in. mm	B in. mm	C in. mm	A in. mm	B in. mm	C in. mm	A in. mm	B in. mm	C in. mm	A in. mm	B in. mm	C in. mm	A in. mm	B in. mm	C in. mm
1/4" & 1/2"	1.6 41	5.2 132	2.2 56	2.4 61	5.3 135	2.3 59	2.1 53	5.3 135	2.8 71	2.2 56	6.3 160	3.3 84	3.1 78	6.7 170	4.0 102
3/4" & 1"	1.6 41	5.7 145	2.2 56	2.4 61	5.8 147	2.3 59	2.1 53	5.8 147	2.8 7.1	2.2 56	6.8 173	3.3 84	3.1 78	7.2 183	4.0 102

**NOTE:** W20, E20 and E58 coils are equipped with 1/2" NPT conduit connection.

\*Not available on 1/4 and 1/2 EASYM and EASYMD.

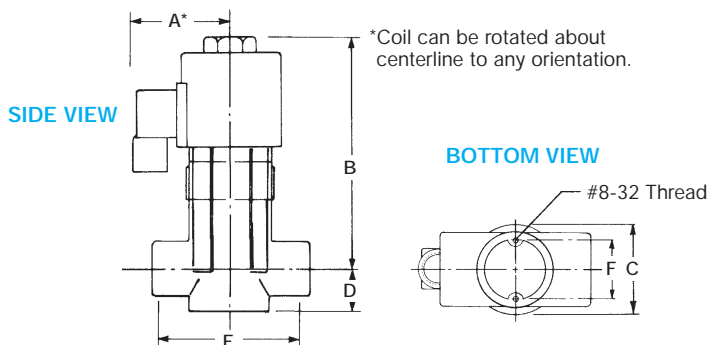

### VALVE BODY DIMENSIONS

Pipe Size	D In. mm	E In. mm	F** In. mm
1/4" & 1/2"	.94 24	3.3 84	1.5 38
3/4" & 1"	1.3 33	4.0 102	1.5 38

\* For dimensions of PP and PTFE machined valves, consult factory.

\*\* Dimension is from center to center of mounting holes.

†† To order connector assembly with light, use appropriate. Model number and specify "with indicator light".

# COIL INFORMATION

**General Information:** A solenoid coil is basically a simple electro-mechanical unit used to control the opening and closing of valve. Energizing the coil creates a magnetic field which lifts the shaft and seat of the valve off its orifice. When de-energized a small spring pushes the shaft and seat down to close the valve. Response time is approximately 1/10 second.

**Coil Selection:** The coil used on Plast-O-Matic solenoid valves are available in 20 and 58 watts with AC voltage of 24, 120, 240 and 480 at 60 Hz. They can also be used with voltages 15 percent less and with 50 Hz. Standard DC voltages are 12 and 24.

Below are described the types of coils available to meet various NEMA requirements.

**Duty Cycles:** Duty cycle is rated either continuous or intermittent. A coil rated with a 100% duty cycle does not require time to cool-down and is thus called continuous duty. A duty cycle of anything less than 100% is called intermittent duty. Ambient temperature has an effect on the rating.

**Duty Cycle 20 Watt:** All 20 Watt coils are rated continuous duty up to 102°F (40°F) ambient. Above this temperature they are rated intermittent duty requiring a cool-down period before re-energizing. A general rule of thumb for ambient temperatures between 102°F (40°C) and 122°F (50°C) is to allow an equal amount of cool-down time as compared to energized time with a maximum on time of 1/2 hour. At higher temperatures more cool-down time is needed.

**Duty Cycle 58 Watt:** The 58 watt coils are rated intermittent service with a 50% duty cycle. Up to 77°F (25°C) ambient, they can be operated for a maximum of 25 minutes on and 15 minutes off, or any shorter period of on and off cycles. Between 77°F (25°C) and 95°F (35°C) the coils can be operated for a maximum of 10 minutes on and 20 minutes off, or any relative shorter periods of time. It is not recommended at higher ambient temperatures.

**Cautions:** Coils exposed to voltages in excess of their rated nominal voltage will operate hotter than intended which could lead to coil and valve damage. Rapid cycling of AC coils can also cause overheating; does not apply to DC coils. Consult factory for specific information.

## COIL TYPES



W20

**W20 (20 watt coil):** Water and dust-tight polyester solenoid enclosures are part of the coil and are completely molded. They meet NEMA-4X requirements for indoor and outdoor service and are both water and dust-tight, and suited for corrosive atmospheres compatible with polyester and nylon. Valve pictured on front of this brochure is shown with W20 coils. The coils come standard with an unlighted 1/2" NPT female external connector assembly. This type of connector allows internal electrical connection to be made easily while disconnected from the coil. The external cable connection to the housing may be arranged at any one of the 4 angles (90° increments) to facilitate valve installation. A connector assembly can also be ordered with an optional indicator light which shows when the solenoid is energized. The connector meets DIN 43650 Form A.



G20 & G58

**G20 (20 watt coil) and G58 (58 watt coil):** General purpose solenoid enclosures have pressed steel housings epoxy coated for general purpose NEMA-1 applications – indoors and where atmospheric conditions are not a problem.



E20 & E58

**E20 (20 watt coil) and E58 (58 watt coil):** Have an explosion-proof and water-tight enclosure of die cast aluminum or pressed steel epoxy coated. They meet NEMA-7 requirements for Class 1 hazardous locations, Group C and D atmospheres containing volatile gases and fumes. Also, they meet NEMA-9 for Class 2 hazardous locations consisting of atmospheres of explosive metallic dust (Group E), carbon black, coal or coke dust (Group F) and flour a, starch or grain dust (Group G).

## SPECIFICATIONS

STYLE	Image	Features	INSULATION CLASS	
			COIL SURFACE TEMPERATURE	F
<b>G20 &amp; E20</b> 20 Watt Class "F" Coils <i>Continuous Duty</i>		<ul style="list-style-type: none"> <li>FUNGUS PROOF</li> <li>MOISTURE PROOF</li> <li>LOW TEMP. RISE/ WATT</li> <li>WIDER OPERATING RANGE</li> </ul>	245°F	F
			118°C	
			95°F	
			35°C	
<b>W20</b> 20 Watt Class "F" Coils <i>Continuous Duty</i>		<ul style="list-style-type: none"> <li>CORROSION RESISTANT</li> <li>CONTINUOUS DUTY</li> <li>SAFE OPERATING TEMP.</li> <li>NEMA 4 WATER AND DUST-TIGHT ENCLOSURE</li> <li>MOISTURE PROOF</li> <li>FUNGUS PROOF</li> </ul>	235°F	F
			112°C	
			102°F	
			40°C	
<b>G58 &amp; E58</b> 58 Watt Class "H" Coils <i>Intermittent Duty</i>		<ul style="list-style-type: none"> <li>FUNGUS PROOF</li> <li>RADIATION RESISTANT</li> <li>WIDER OPERATING RANGE</li> <li>GLASS INTERWOVEN CONSTRUCTION</li> </ul>	290°F	F
			143°C	
			77°F	
			25°C	
			88	
			32	
			107	
			46	
			295	
			130	

**NOTE:** Information on table is for AC voltages.  
For specific information on DC voltages, contact the factory.

\* With power on continuously  
† 58W coils should not be operated longer than 15 mins. at 77°F (25°C) ambient.

**PLAST-O-MATIC**  
VALVES, INC.

Authorized Stocking Distributor **KTH Sales, Inc.**  
(219) 736-0060 • Fax (219) 769-0263  
www.KTHSales.com • Sales@KTHSales.com