

**NEW!**

## Teflon® Bellows Solenoid Valve Prevents Fugitive Emission Leaks

One Valve Handles All Type Solutions!

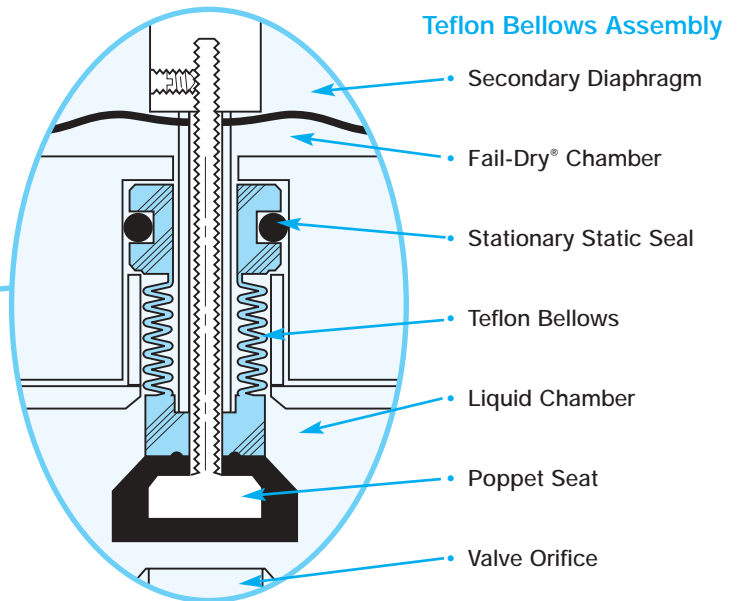
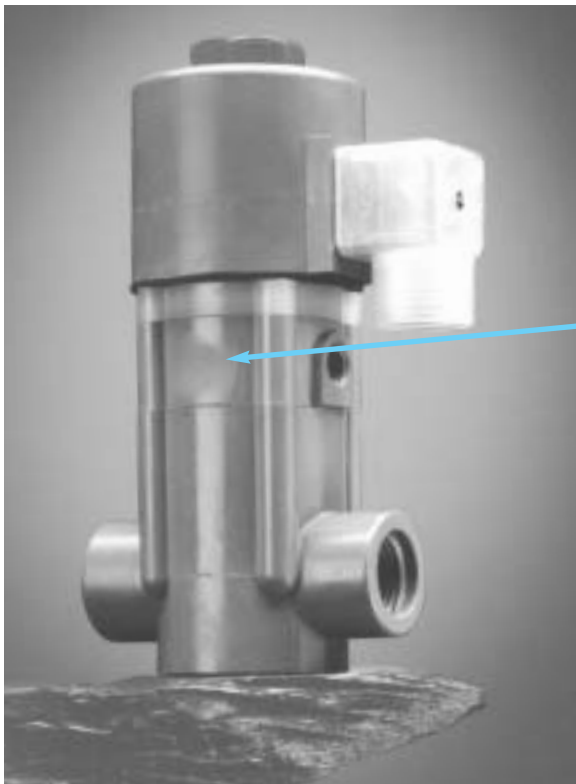

### *Technological and engineering breakthrough...*

A single thermoplastic valve, designed for severe service applications with virtually every type of liquid. For pressure, drain or vacuum service. Sizes: 1/4" to 1".

### OUTSTANDING FEATURES

- **Unique Design:** Teflon Bellows barrier-type dynamic seal prevents leaking of fugitive emissions to the atmosphere.
- **Versatility:** For use with virtually every type solution, including acids, caustics, solvents, chlorine solutions and ultra-pure liquids.
- **Superior Performance:** Over 2 million cycles possible.
- **Dependability and Safety:** Patented Fail Dry® design provides visual warning if seal malfunctions. Avoids costly shutdown, as valve continues to function.
- **Corrosion Resistant:** Rugged thermoplastic construction is resistant to both internal and atmospheric corrosion. no metal parts in wetted areas. Available in PVC, CPVC, Polypropylene and Kynar® PVDF.
- **Exacting Quality:** All valves individually inspected and 100% tested to insure reliable operation.
- **Coil Connector Light Option:** Indicates when valve is energized (open).
- **Cost Efficiency:** All-purpose design permits phase-out of multi-type valve stocking.

*Leadership Though Innovative Products, Engineering Excellence and Dependable Performance!*

# TEFLON BELLOWS SOLENOID VALVES

## APPLICATION • DESIGN • OPERATION

**Application:** Teflon bellows solenoid valves automatically shutoff flow of highly corrosive or ultra-pure liquids including acids, caustics, solvents and chlorine solutions. They can handle pressure, drain or vacuum applications and do not require pressure to aid in opening the valve.

**Design and Operation:** Valves are spring return normally-closed and direct-acting with a simple push-pull plunger design. There is no minimum pressure required for operation. The Teflon bellows shaft seal eliminates the need for an elastomer seal which can weaken as a result of chemical attack. The Teflon bellows assures non-sticking operation and exceptionally long cycle life; over 2 million cycles. The bellows design also allows a stock valve to be used for vacuum or pressure. The poppet seat insures bubble-tight shutoff.



**Fail Dry® Safety Design:** Unique protection is provided by Plast-O-Matic's patented Fail-Dry design which incorporates a vented chamber and a secondary back-up diaphragm to handle any unusual seal failure occurrence. The Fail-Dry safety feature provides visual warning of seal malfunction and permits the valve to continue operating until a scheduled maintenance can be planned thereby avoiding a costly shutdown.

**Vacuum Information:** Teflon Bellows solenoid valves are rated for full vacuum of 30" of mercury except for 1" sizes are rated for a vacuum of 15" of mercury.

## MATERIALS OF CONSTRUCTION

**Bodies:** Teflon bellows solenoid valve bodies are available in a broad range of materials. Series EASYMT and EASMT molded bodies are available in PVC, CPVC, glass-filled polypropylene and Kynar PVDF. Some components in glass-filled polypropylene EASYMT and EASMT are made of Kynar PVDF.

**Seals:** Standard seal material for all molded and machined Bellows solenoid valves is a special treated Viton®. With this material, a single valve can handle virtually all types of solutions including acids, caustics, solvents, chlorine solutions and ultra-pure liquids. Multi-purpose capability results in significant convenience and cost efficiency, since only one valve is needed for inventory.

### NEW 20 WATT COIL

Standard production for Teflon bellows solenoid valves includes the new W20 (20 watt) coil. This molded unit is equipped with a separate DIN standard connector having a 1/2" NPT female connection and a design which allows internal electrical connections to be made easily while apart from the coil.

### CONNECTOR LIGHT

The bellows solenoid valves can also be ordered with a unique connector indicator light. With this optional feature, the connector lights up brightly to show when the solenoid is energized.

*For complete coil information, see back page.*

## TEMPERATURE REFERENCE MATERIAL

The following chart is to provide overall guidelines on various thermoplastics relative to their pressure and temperature relationships. The information should be used

to determine limitations of the various materials rather than selection of a specific valve since each individual valve model had its own pressure ratings.

MATERIAL TEMPERATURE vs. PRESSURE																
Material	Maximum Temperature Rating		MAXIMUM INLET PRESSURE AND TEMPERATURE													
			75°F PSI	24°C BARS	110°F PSI	43°C BARS	140°F PSI	60°C BARS	180°F PSI	82°C BARS	220°F PSI	105°C BARS	240°F PSI	116°C BARS	284°F PSI	140°C BARS
PVC	140°F	(60°C)	140	9,6	100	6,8	40	2,7	N.R.	N.R.	N.R.	N.R.	N.R.	N.R.	N.R.	
CPVC	180°F	(82°C)	140	9,6	100	6,8	80	5,4	40	2,7	N.R.	N.R.	N.R.	N.R.	N.R.	
GPP**	220°F	(105°C)	140	9,6	120	8,2	100	6,8	80	5,4	40	2,7	N.R.	N.R.	N.R.	
PVDF	284°F	(140°C)	140	9,6	130	8,8	120	8,2	100	6,8	60	4,1	30	2,0	10	0,7

\*\*GPP – Glass-filled Polypropylene for molded valves

N.R. –Not Recommended

# PRESSURE RATING CONSIDERATIONS FOR ALL MODELS

**Inlet Pressure:** Inlet pressure ratings in the tables below are at full rated line voltage for alternating current (A.C.) or direct current (D.C.) If line voltage is 15% lower, inlet pressure rating will be about 30% lower. If rated pressures are exceeded the valve will not open and the coil could burn out.

**Back Pressure:** An important consideration in solenoid valve selection is the back pressure rating shown in the spec table. Back pressure is caused by the resistance to flow in the piping downstream of the valve. Nozzles, goosenecks, fittings, tubing, or reduced outlet piping all create restrictions that raise the back pressure. Excessive

back pressure will cause a valve to remain open when power is shut off. A second type of back pressure is that which comes from a separate pressure source downstream of the valve. This could be head pressure from a storage tank or pressure from another pump, etc. Plast-O-Matic solenoid valves will not stay closed if the back pressure is higher than the inlet pressure. *Back pressure or downstream pressure is the most common cause of solenoid valve problems during system start-up. Therefore, sources of potential backpressure must be considered during the planning stages of a piping system.*

SPECIFICATIONS AND MODEL NUMBERS SERIES EASYMT AND EASMT														
Pipe Size	Orifice Size		Watts	AC COILS				DC COILS				Molded Body Viton® Seals Model Numbers		
	In.	mm		Cv	Max. Inlet Pressure		Max. Back Pressure		Cv	Max. Inlet Pressure			Max. Back Pressure	
					PSI	BARS	PSI	BARS		PSI	BARS	PSI	BARS	
1/4	.375	9,5	20	1.1	140	9,5	38	2,6	1.1	70	4,8	19	1,3	EASYMT2V12W20
1/2	.375	9,5	20	1.1	140	9,5	38	2,6	1.1	70	4,8	19	1,3	EASYMT4V12W20
1/2	.375	9,5	20	2.1	125	8,5	18	1,2	1.6	60	4,1	18	1,2	EASMT4V12W20
3/4	.470	12,7	20	3.1	58	3,9	17	1,1	2.2	25	1,7	17	1,1	EASMT5V16W20
1	.656	16,7	20	4.6	15	1,0	12	0,8	4.0	8	0,5	8	0,8	EASMT6V22W20
1**	.452	11,5	20	3.6	25	1,7	12	0,8	2.9	13	0,9	12	0,8	EASMT6V14W20
1/2	.375	9,5	58	2.3	140	9,5	38	2,6	NA	NA		NA		EASMT4V12G58
3/4	.470	12,7	58	3.4	120	8,2	34	2,3	NA	NA		NA		EASMT5V16G58
1	.656	16,7	58	4.7	70	4,8	34	2,3	NA	NA		NA		EASMT6V22G58

- The Model Numbers listed show Viton seals. For EPDM seals (optional) change "V" to "EP" and for Buna-N seals (optional) change the "V" to "B". Prices are the same for all seals mentioned.
- Model Numbers are shown with "W20" (water and dust tight NEMA 4 style coil) and "G58" (general purpose coil). For explosion proof coils change the "W20" to "E20" and the "G58" to "E58". If a "G20" general purpose ASCO coil is desired change the "W20" to "G20"; the list price is the same. Voltage must be specified with order.
- Inlet pressure rating for G20 & E20 coils are 25% less than the W20 ratings which are shown above.

- All Model Numbers must be completed with body material at the end as follows: For Molded Bodies: PVC with "PV", CPVC with "CP", glass filled Polypropylene with "GPP" and PVDF (Kynar) with "PF".
- Valves in above chart are rated for full vacuum of 30" of mercury (Hg) except for 1" sizes which are rated for 15" of mercury (Hg) maximum.
- The 20 watt coils are rated continuous duty, 58 watt coils are intermittent duty. See Coil Information Section on back page for complete details.
- 20W coil available with 24 volt DC for models EASYMT and EASMT4, with no reduction in inlet pressure.

## SOLENOID COIL HOUSING DIMENSIONS

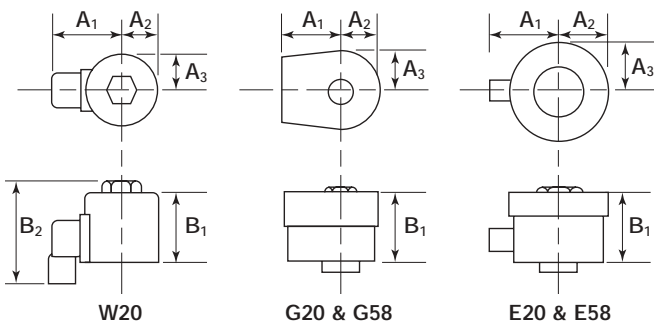

## SOLENOID COIL HOUSINGS

Coil Type	A1	A2	A3	B1	B2
	In. mm	In. mm	In. mm	In. mm	In. mm
<b>W20 NEMA-4 Water &amp; Dust Proof</b>	2.4 61	1.2 30	1.2 30	2.4 62	3.0 75
<b>G20 NEMA-1 General Purpose</b>	1.6 41	1.1 28	1.1 28	2.2 55	---
<b>E20 NEMA-7 and 9 Explosion Proof</b>	2.2 55	1.4 35	1.4 35	2.4 62	---
<b>G58 NEMA-1 General Purpose</b>	2.2 55	1.7 44	1.7 44	2.9 74	---
<b>E58 NEMA-7 and 9 Explosion Proof</b>	3.1 78	1.7 44	2.0 52	3.3 84	---

## SOLENOID VALVE BODY DIMENSIONS

*Molded Body with W20 Coil\**

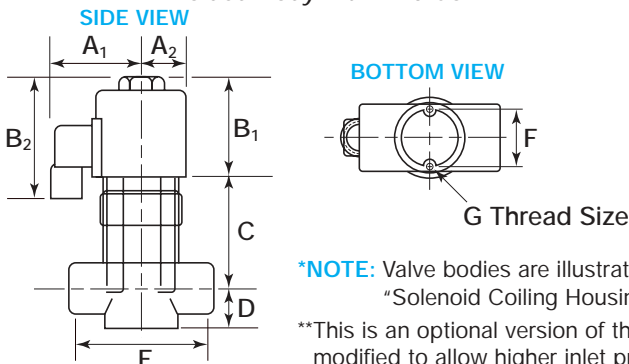

## MOLDED VALVE BODIES - SERIES EASYMT & EASMT

Pipe Size	C	D	E	F†	G
	In. mm	In. mm	In. mm	In. mm	Thread Size
1/4" & 1/2"	2.9 73	.94 24	3.3 84	1.5 38	8-32 x 1/2 deep
3/4" & 1"	3.3 84	1.3 33	4.0 102	1.5 38	8-32 x 1/2 deep

† Dimension is from center to center of mounting holes

**\*NOTE:** Valve bodies are illustrated with W20 coils. If another coil is substituted, refer to "Solenoid Coiling Housing Dimensions" section above for appropriate information.

\*\*This is an optional version of the 1" valve, where the design has been modified to allow higher inlet pressure at the sacrifice of lower Cv.

# COIL INFORMATION

**General Information:** A solenoid coil is basically a simple electro-mechanical unit used to control the opening and closing of a valve. Energizing the coil creates a magnetic field which lifts the shaft and seat of the valve off its orifice. When de-energized a small spring pushes the shaft and seat down to close the valve. Response time is approximately 1/10 second.

**Coil Selection:** The coil used on Plast-O-Matic solenoid valves are available in 20 and 58 watts with AC voltage of 24, 120, 240 and 480 at 60 Hz. They can also be used with voltages 15 percent less and with 50 Hz. Standard DC voltages are 12 and 24.

Below are described the types of coils available to meet various NEMA requirements.

**Duty Cycles:** Duty cycle is rated either continuous or intermittent. A coil rated with a 100% duty cycle does not require time to cool-down and is thus called continuous duty. A duty cycle of anything less than 100% is called intermittent duty. Ambient temperature has an effect on the rating.

**Duty Cycle 20 Watt:** All 20 watt coils are rated continuous duty up to 102°F (40°C) ambient. Above this temperature they are rated inter-mittent duty requiring a cool-down period before re-energizing. A general rule of thumb for ambient temperatures between 102°F (40°C) and 122°F (50°C) is to allow an equal amount of cool-down time as compared to energized time with a maximum on time of 1/2 hour. At higher temperatures more cool-down time is needed.

**Duty Cycle 58 Watt:** The 58 watt coils are rated intermittent service with a 50% duty cycle. Up to 77°F (25°C) ambient, they can be operated for a maximum of 25 minutes on and 15 minutes off, or any shorter period of on and off cycles. Between 77°F (25°C) and 95°F (35°C) the coils can be operated for a maximum of 10 minutes on and 20 minutes off, or any relative shorter periods of time. It is not recommended at higher ambient temperatures.

**Cautions:** Coils exposed to voltages in excess of their rated nominal voltage will operate hotter than intended which could lead to coil and valve damage. Rapid cycling of AC coils can also cause overheating; does not apply to DC coils. Consult factory for specific information.

## COIL TYPES



W20

**W20 (20 watt coil):** Water and dust-tight polyester solenoid enclosures are part of the coil and are completely molded. They meet NEMA-4X requirements for indoor and outdoor service and are both water and dust-tight, and suited for corrosive atmospheres compatible with polyester and nylon. Valve pictured on front of this brochure is shown with W20 coils. The coils come standard with an unlighted 1/2" NPT female external connector assembly. This type of connector allows internal electrical connection to be made easily while disconnected from the coil. The external cable connection to the housing may be arranged at any one of the 4 angles (90° increments) to facilitate valve installation. A connector assembly can also be ordered with an optional indicator light which shows when the solenoid is energized. The connector meets DIN 43650 Form A.



G20 & G58

**G20 (20 watt coil) and G58 (58 watt coil):** General purpose solenoid enclosures have pressed steel housings epoxy coated for general purpose NEMA-1 applications – indoors and where atmospheric conditions are not a problem.



E20 & E58

**E20 (20 watt coil) and E58 (58 watt coil):** Have an explosion-proof and water-tight enclosure of die cast aluminum or pressed steel epoxy coated. They meet NEMA-7 requirements for Class 1 hazardous locations, Group C and D atmospheres containing volatile gases and fumes. Also, they meet NEMA-9 for Class 2 hazardous locations consisting of atmospheres of explosive metallic dust (Group E), carbon black, coal or coke dust (Group F) and flour a, starch or grain dust (Group G).

## SPECIFICATIONS

STYLE	Image	Features	INSULATION CLASS	
			COIL SURFACE TEMPERATURE	F
<b>G20 &amp; E20</b> 20 Watt Class "F" Coils <i>Continuous Duty</i>		<ul style="list-style-type: none"> <li>FUNGUS PROOF</li> <li>MOISTURE PROOF</li> <li>LOW TEMP. RISE/ WATT</li> <li>WIDER OPERATING RANGE</li> </ul>	245°F	F
			118°C	
			95°F	
			35°C	
<b>W20</b> 20 Watt Class "F" Coils <i>Continuous Duty</i>		<ul style="list-style-type: none"> <li>CORROSION RESISTANT</li> <li>CONTINUOUS DUTY</li> <li>SAFE OPERATING TEMP.</li> <li>NEMA 4 WATER AND DUST-TIGHT ENCLOSURE</li> <li>MOISTURE PROOF</li> <li>FUNGUS PROOF</li> </ul>	235°F	F
			112°C	
			102°F	
			40°C	
<b>G58 &amp; E58</b> 58 Watt Class "H" Coils <i>Intermittent Duty</i>		<ul style="list-style-type: none"> <li>FUNGUS PROOF</li> <li>RADIATION RESISTANT</li> <li>WIDER OPERATING RANGE</li> <li>GLASS INTERWOVEN CONSTRUCTION</li> </ul>	290°F	H
			143°C	
			77°F	
			25°C	
			295	
			130	

**NOTE:** Information on table is for AC voltages.  
For specific information on DC voltages, contact the factory.

\* With power on continuously  
† 58W coils should not be operated longer than 15 mins. at 77°F (25°C) ambient.

**PLAST-O-MATIC**  
 VALVES, INC.

Authorized Stocking Distributor

KTH Sales, Inc. ph 219-736-0060 Fax: 219-769-0263  
 www.KTHSales.com • sales@KTHSales.com