

REFERENCE GUIDE

- Pump Selection Chart
- Pump Specifications
- Dimensions



It's Easy To Select The Pump You Need

Follow the step by step approach to choosing the features you need, and when you're through, you'll have the exact model number for the PULSAtron® pump you want.

Model Selection Guide

Position **1, 2** Series Name

Series MP = LM; Series E PLUS = LP;
Series E = LE; Series E-DC = LS;
Series A PLUS = LB; Series C PLUS = LD;
Series C = LC

Position **3, 4** Size

Pressure and Capacity (Use charts below)

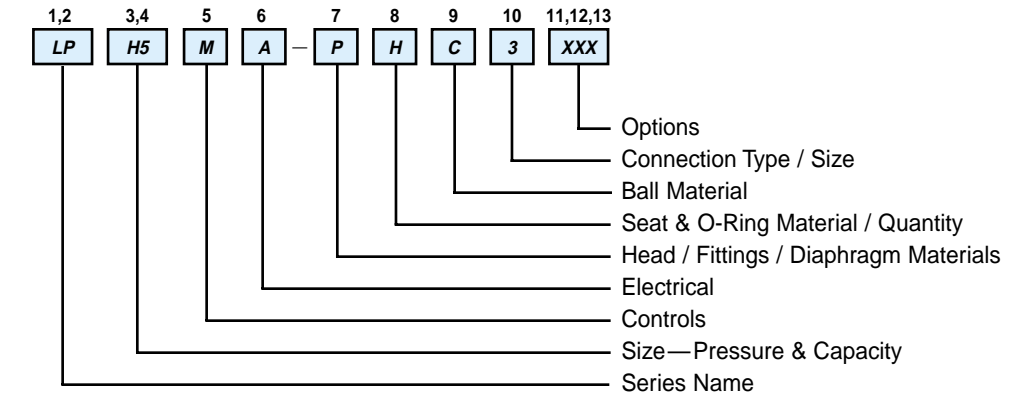

SERIES MP / E PLUS

Capacity, nominal	GPD	3	5	6	11	12	14	20	21	24	40	42	44	60	75	94	120	190	240	500
	GPH	0.13	0.20	0.25	0.45	0.50	0.58	0.83	0.87	1.0	1.66	1.75	1.83	2.5	3.17	3.91	5.00	8.00	10.00	20.00
LPH	.47	.79	.95	1.73	1.89	2.21	3.15	3.31	3.78	6.31	6.62	6.94	9.46	11.8	14.8	18.9	29.9	37.8	78.9	
Pressure, max PSIG / Bar																				
300 / 21		K2	—	—	—	—	—	—	—	—	—	—	—	—	—	—	—	—	—	—
250 / 17		—	B2	—	D3	—	—	F4	—	—	H4	—	—	—	—	—	—	—	—	—
150 / 10		—	—	A2	—	B3	—	—	D4	—	—	G4	—	K5	H5	—	—	—	—	—
100 / 7		—	—	—	—	A3	K3	—	—	B4	—	—	E4	—	—	G5	H6	—	—	—
50 / 3.3		—	—	—	—	—	—	—	—	—	—	—	—	—	—	—	—	K7	—	—
35 / 2.4		—	—	—	—	—	—	—	—	—	—	—	—	—	—	—	—	—	H7	—
20 / 1.3		—	—	—	—	—	—	—	—	—	—	—	—	—	—	—	—	—	—	H8

SERIES E

Capacity, nominal	GPD	5	6	11	12	21	24	44
	GPH	0.20	0.25	0.45	0.50	0.87	1.0	1.83
LPH	.79	.95	1.73	1.89	3.31	3.78	6.94	
Pressure, max PSIG / Bar								
250 / 17		12	—	33	—	—	—	—
150 / 10		—	02	—	13	34	—	—
100 / 7		—	—	—	03	—	14	44

SERIES E-DC

Capacity, nominal	GPD	6	12	24	44
	GPH	0.25	0.50	1.0	1.83
LPH	.95	1.89	3.78	6.94	
Pressure, max PSIG / Bar					
150 / 10		02	13	—	—
100 / 7		—	—	14	14

SERIES C PLUS

Capacity, nominal	GPD	6	12	22	30
	GPH	0.25	0.50	0.91	1.25
LPH	.95	1.89	3.47	4.73	
Pressure, max PSIG / Bar					
80 / 5.6		02	03	04	54

SERIES C

Capacity, nominal	GPD	6	12	22	30
	GPH	0.25	0.50	0.91	1.25
LPH	.95	1.89	3.47	4.73	
Pressure, max PSIG / Bar					
80 / 5.6		02	03	04	54

SERIES A PLUS

Capacity, nominal	GPD	6	12	22	30
	GPH	0.25	0.50	0.91	1.25
LPH	.95	1.89	3.47	4.73	
Pressure, max PSIG / Bar					
150 / 10		02	03	—	—
100 / 7		—	—	04	64

Position **5** Controls

	Series MP	Series E PLUS	Series E	Series A PLUS, C PLUS	Series C
Manual stroke length only	—	—	—	—	S
Manual, dual function	—	S	S	S	—
External Pacing, w/ Stop	—	E	—	—	—
4-20 mA DC direct, w/ Stop	—	M	—	—	—
External Pacing only	—	—	—	E	E
Liquid Level Stop only	—	—	—	P	P
Signal Level Relay	T	—	—	—	—
Power Level Relay	K	—	—	—	—

Position **6** Electrical (All Series)

115 VAC / 50-60 Hz / 1ph, with 6 ft., 3 wire U.S. power cord and grounded plug and ETL approval	A
115 VAC / 50-60 Hz / 1ph, with 6 ft., 3 wire U.S. power cord and grounded plug and no agency approvals	1

230 VAC / 50-60 Hz / 1ph, with 6 ft., 3 wire U.S. power cord and grounded plug and ETL approval	B
230 VAC / 50-60 Hz / 1ph, with 6 ft., 3 wire U.S. power cord and grounded plug and no agency approvals	2

Position 7 Head/Fittings/Diaphragm Material¹

	PSI, Max.	Series MP	Series E PLUS	Series E, A PLUS, C PLUS	Series C
PVDF/PVDF/TFE-faced HYP**	300	K	K	K	K
316SS/316SS/TFE-faced HYP	300	A	A	A	A
GFPPL/GFPPL/TFE-faced HYP	300	P	P	P	P
PVC/PVC/TFE-faced HYP	150	V	V	V	V
SAN/PVC/TFE-faced HYP	150	S	S	S	S

¹Not available on H8 models pumps.

Position 8 Seat and O-Ring Material/Quantity of Checks

	PSI, Max.	Series
		MP, E-DC, E PLUS, E, A PLUS, C PLUS, C
Teflon / double*	300	T
Hypalon / single	150	H
Viton / single	150	V

*Pumps having discharge pressures 250 PSI and/or using the J connection must have Teflon seats.

Position 9 Ball Material

Series MP, E Plus, E, E-DC, A Plus, C Plus, C

Ceramic = C

Teflon = T

316SS = S**

Alloy C = H**

**When using SS or Alloy C balls refer to the pricing guide for special connections if pump is 20 GPD.

Position 10 Connection Type

Viscosity 1000 CPS	Model Capacity GPD, Max	
Tubing - 1/4" x 3/8" / 1/4"	44 GPD	1
Tubing - 3/8" x 1/2" / 1/4"	44 GPD	A
Tubing - 3/8" x 1/2" / 3/8"	44 to 240 GPD	3
Tubing - 1/2" x 3/4" / 1/2"	=500 GPD	B
Piping - 1/4" FNPT / 1/4"	44 GPD	2
Piping - 1/4" FNPT / 3/8"	44 to 240 GPD	4
Piping - 1/2" FNPT / 1/2"	=500 GPD	C
Tubing - 1/4" x 3/8" / 1/4"	<20 GPD*	D
Tubing - 3/8" x 1/2" / 1/4"	<20 GPD*	E
Tubing - 3/8" x 1/2" / 3/8"	<20 GPD*	F
Piping - 1/4" FNPT / 1/4"	<20 GPD*	G
Degas Head	44 GPD**	9
Low Flow "J" Head Assembly	14 GPD	J
Viscosity > 1000 - 3000 CPS < 80 GPD (not avail. in PVDF)		
Use connections 3 or 4 with SST balls		
Viscosity > 3000 CPS (not avail. in PVDF)		
Tubing - (S) 1/2" x 3/4" / .5"	44 GPD	5
(D) 3/8" x 1/2" / .38"		
Tubing - (S) 1/2" x 3/4" / .5"	>44 GPD	7
(D) 1/2" FNPT / .5"		
Tubing - (S) 1/2" x 3/4" / .5"	=500 GPD	K
(D) 1/2" x 3/4" / .5"		
Piping - (S) 1/4" FNPT / .38"	44 GPD	6
(D) 1/4" FNPT / .38"		
Piping - (S) 1/2" FNPT / .5"	>44 GPD	8
(D) 1/2" FNPT / .5"		

*To be used with SS or Hastelloy balls. **Degassing Head Assembly is available in PVC with Viton Seats and Ceramic checks only.

Specifications

Liquid End Materials ¹									
Series	Pump Head	Diaphragm	Check Valves			Fittings	Bleed Valve	Injection Valve Assembly Foot Valve Assembly	Tubing
			Seat / O-rings	Balls					
MP, E PLUS, E, A PLUS, C PLUS and C	GFPPL PVC SAN PVDF 316SS	Teflon-faced Hypalon-backed	Teflon, Hypalon, Viton	Ceramic, Teflon, 316SS, Alloy C	GFPPL PVC PVDF 316SS	Same fitting and check valve selected, except 316SS	Same fitting and check valve selected	Clear PVC White PE	

¹Material Code — GFPPL = Glass-filled Polypropylene, PVC = Polyvinyl Chloride, SAN = Styrene-Acrylonitrile, PVDF = Polyvinylidene Fluoride, TFE = Teflon®, HYP = Hypalon®, NPR = Neoprene, SS = Stainless Steel, PE = Polyethylene. Teflon, Hypalon and Viton are registered trademarks of E.I. DuPont Company.

Position 11, 12, 13 Options

Options	Suffix
UV Resistant Black Tubing (PE or PP)	055
European Power Cord with No Plug	108
European Power Cord with CEE 7	—
Right Angle Plug	113
European Power Cord with CEE 7G	—
Straight Plug	114
PVDF Tubing (3/8" OD or 1/2" OD only)	130
Polypropylene Adapter (H* only)	145
5/8" OD Tubing Connections (H8 only)	147
U.S. Power Cord with No Plug	300
Conduit Box instead of Power Cord	358
Five Function Valve Assembly*	500

*Not available on H8 model pumps or pumps with high viscosity connections.

	SERIES MP	SERIES E PLUS	SERIES E	SERIES E-DC	SERIES A PLUS	SERIES C PLUS	SERIES C
Pressure, max; PSI / BAR @ GPD / GPH / LPH	250 / 17 40 / 1.66 / 6.3	250 / 17 40 / 1.66 / 6.3	250 / 17 11 / .45 / 1.7	150 / 10 12 / .50 / 1.8	150 / 10 12 / .50 / 1.8	80 / 5.6 30 / 1.25 / 4.7	80 / 5.6 30 / 1.25 / 4.7
Capacity (nominal), max; GPD / GPH / LPH @ PSI / BAR	500 / 20 / 79 20 / 1.3	500 / 20 / 79 20 / 1.3	44 / 1.83 / 6.9 100 / 7	44 / 1.83 / 6.9 100 / 7	30 / 1.25 / 4.7 100 / 7	30 / 1.25 / 4.7 80 / 5.6	30 / 1.25 / 4.7 80 / 5.6
Approvals (most models)	ETL, CE	ETL, CE	ETL, CE	—	ETL, CE	ETL, CE	ETL, CE
Reproducibility, at max Capacity; % (±)	2	2	3	3	3	3	3
Viscosity, max; CPS	1000 ²	1000 ²	1000 ²	300 / 1000 ^(c)	1000	1000	1000
Suction Lift @ 1 CPS, max; ft/M @ 3000 CPS	10 / 3.1 3.5 / 1.1 (once primed)	10 / 3.1 3.5 / 1.1 (once primed)	10 / 3.1 3.5 / 1.1 (once primed)	5 / 1.5 N/A (once primed)	5 / 1.5 N/A (once primed)	5 / 1.5 N/A (once primed)	5 / 1.5 N/A (once primed)
Stroke Frequency, max; SPM	125	125	125	125	125	125	125
Stroke Frequency Control (Automatic)	4-20mADC or 20-4mADC, External Pacing, w/Stop	4-20mADC Direct, w/Stop* External Pacing, w/Stop	N/A	N/A	External Pacing*	External Pacing*	External Pacing*
Stroke Frequency Control (Manual)	On-Line Adjustable	On-Line Adjustable	On-Line Adjustable	On-Line Adjustable	On-Line Adjustable	On-Line Adjustable	N/A
Stroke Frequency Turn-Down Ratio	100:1	10:1	10:1	10:1	10:1	10:1	N/A
Stroke Length Control (Manual)	On-Line Adjustable	On-Line Adjustable	On-Line Adjustable	On-Line Adjustable	On-Line Adjustable	On-Line Adjustable	On-Line Adjustable
Stroke Length Turn-Down Ratio	10:1	10:1	10:1	10:1	10:1	10:1	5:1
Power Input	115VAC / 50-60Hz / 1 ph 230VAC / 50-60Hz / 1 ph	115VAC / 50-60Hz / 1 ph 230VAC / 50-60Hz / 1 ph	115VAC / 50-60Hz / 1 ph 230VAC / 50-60Hz / 1 ph	12.6 VDC Nominal Range 11.8 - 14.0 VDC	115VAC / 50-60Hz / 1 ph 230VAC / 50-60Hz / 1 ph	115VAC / 50-60Hz / 1 ph 230VAC / 50-60Hz / 1 ph	115VAC / 50-60Hz / 1 ph 230VAC / 50-60Hz / 1 ph
Average Current Draw @ 115 VAC; Amps	1.0	1.0	0.6	6.0 / 8.0 ^(d)	0.6	0.6	0.6
Peak Input Power; Watts	300	300	130	141.6 / 189.0 ^(d)	130	130	130
Average Input Power @ max SPM; Watts	130	130	50	76.0 / 100.8 ^(d)	50	50	50
Circuit Board Protection	Circuit Breaker (Panel-Mount)	Fuse, 2.0 Amp (Panel-Mount)	Fuse, 1.5 Amp (Board-Mount)	Fuse, 20 Amp (Board-Mount)	Fuse, 1.5 Amp (Board-Mount)	Fuse, 1.5 Amp (Board-Mount)	Fuse, 1.5 Amp (Board-Mount)
Output Relay	Signal Level, Power Level	—	—	—	—	—	—
Max Ambient Temperature / Relative Humidity	104°F / 90%	104°F / 90%	104°F / 90%	104°F / 90%	104°F / 90%	104°F / 90%	104°F / 90%
Injection Back Pressure Valve, w/Tubing	Standard	Standard	Standard	Standard	Standard	Standard	Standard
Foot Valve / Strainer, w/Tubing	Standard ^(a)	Standard ^(a)	Standard ^(a)	Standard	Standard	Standard	Standard
Bleed Valve Assembly, w/Tubing	Standard ^(b)	Standard ^(b)	Standard ^(b)	Standard ^(b)	Standard ^(b)	Standard ^(b)	Standard ^(b)
Controls	6 Station Membrane Switch	On-Off or Auto-Off-Manual	N/A	N/A	N/A	N/A	N/A
LED Indicator Lights, Panel Mount	Power On - Green Stop - Red	Power On - Green Stop (w/Auto) — Red	N/A	N/A	N/A	N/A	N/A
Transparent Control Panel Cover	Standard	Standard	N/A	N/A	N/A	N/A	N/A

² For Viscosities > 1000 CPS, refer to pricing guide for special connections.
^(a) Not available with High Viscosity (> 3000 CPS) connections.

^(b) Not available with Piping Discharge Connections.
^(c) LS02, LS13 = 300 CPS / LS14, LS44 = 1,000CPS.

^(d) LS02, LS13, LS14 = 6.0 AMP / LS44 = 8.0 AMP
*Automatic controls are optional on these pumps.

Key Features

Series MP

- Automatic control via 4-20mADC, 20-4mADC or External Pacing
- Six button touchpad control
- Highly reliable microprocessor-based electronic circuit
- Relay and Stop outputs
- 1000:1 turndown
- Available in three languages
- Thermally protected solenoid with auto reset
- Panel mounted circuit breaker
- 16 character LCD display and indicator lights
- Bleed valve assembly



Series E, E-DC, A PLUS and C PLUS

- Manual function controls for Stroke Rate and Stroke Length
- Optional External Pacing Control or liquid level stop function available on C PLUS and A PLUS models
- Highly reliable timing circuit
- EMI resistant
- Thermally protected solenoid with auto-reset
- Bleed valve assembly



Series C

- Our lowest cost model
- Manual function control for Stroke Length
- Optional External Pacing Control or liquid level stop function available
- Highly reliable timing circuit
- EMI resistant
- Thermally protected solenoid with auto-reset
- Bleed valve assembly



Series E PLUS

- 4-20mADC and Stop inputs, or External Pacing and Stop inputs are available options
- Auto-Off-Manual switch
- Highly reliable timing circuit
- EMI resistant
- Thermally protected solenoid with auto-reset
- Panel mounted fuse
- Indicator lights
- Bleed valve assembly



Dimensions

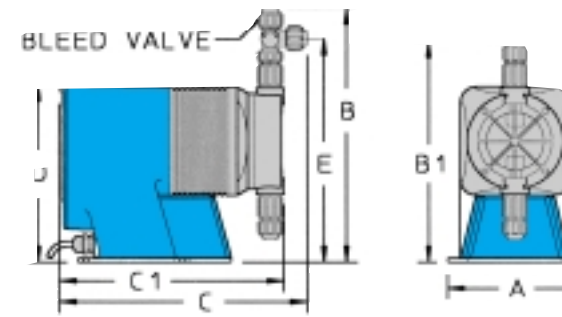

SERIES MP / E PLUS DIMENSIONS (inches)								
Model No.	A	B	B'	C	C'	D	E	Shipping Weight (lbs.)
A2	5.4	10.3	—	10.8	—	7.5	9.0	13
A3	5.4	10.6	—	10.7	—	7.5	9.2	13
B2	5.4	10.3	—	10.8	—	7.5	9.0	13
B3	5.4	10.6	—	10.7	—	7.5	9.2	13
B4	5.4	10.6	—	10.7	—	7.5	9.2	13
D3	5.4	10.6	—	10.7	—	7.5	9.2	15
D4	5.4	10.6	—	10.2	—	7.5	9.2	15
E4	5.4	10.6	—	10.2	—	7.5	9.2	15
F4	5.4	10.6	—	10.7	—	7.5	9.2	18
G4	5.4	10.6	—	10.7	—	7.5	9.2	18
G5	5.4	11.0	—	10.7	—	7.5	9.6	18
H4	6.1	11.0	—	10.2	—	8.2	9.6	21
H5	6.1	11.3	—	10.2	—	8.2	10.0	21
H6	6.1	11.3	—	10.2	—	8.2	10.0	21
H7	6.1	11.7	—	10.2	—	8.2	10.3	21
H8*	6.1	—	10.9	—	10.6	8.2	—	25
K2	5.4	10.3	—	10.8	—	7.5	9.0	13
K3	5.4	10.6	—	10.7	—	7.5	9.2	13
K5	5.4	11.0	—	11.7	—	7.5	9.6	18
K7	6.1	11.7	—	11.2	—	8.2	10.3	21

Note: Inches x 2.54 = cm
*The H8 is designed without a bleed valve.

Specifications subject to change without notice.

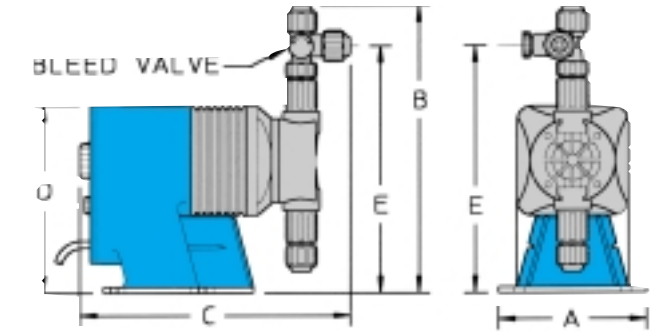

SERIES E / E-DC DIMENSIONS (inches)						
Model No.	A	B	C	D	E	Shipping Weight (lbs.)
02	5.0	9.6	9.6	6.5	8.2	10
03	5.0	9.9	9.5	6.5	8.5	10
12	5.0	9.6	9.6	6.5	8.2	10
13	5.0	9.9	9.5	6.5	8.5	10
14	5.0	9.9	9.5	6.5	8.5	10
33	5.4	10.6	11.4	7.5	9.2	15
34	5.4	10.6	11.4	7.5	9.2	15
44	5.4	10.6	11.4	7.5	9.2	15

Note: Inches x 2.54 = cm

SERIES C / C PLUS / A PLUS DIMENSIONS (inches)						
Model No.	A	B	C	D	E	Shipping Weight (lbs.)
02	5.0	9.6	9.6	6.5	8.2	10
03	5.0	9.9	9.5	6.5	8.5	10
04	5.0	9.9	9.5	6.5	8.5	10
54/64	5.0	9.9	9.5	6.5	8.5	10

Note: Inches x 2.54 = cm

PULSAtron® KOPkits® will save you time and money.

Pulsafeeder has built a reputation for superior reliability by supplying carefully designed, high quality equipment. Even the best equipment, however, requires a minimal amount of maintenance. KOPkits are designed to guard against unnecessary downtime and assure you the highest level of efficient and uninterrupted service from our PULSAtron pumps. KOPkits contain recommended spare parts for those parts that usually require preventative maintenance. KOPkits are immediately available in all wetted materials at very affordable prices.



An ISO 9002 System-Certified Company

PULSAFEEDER

A Unit of IDEX Corporation



Standard Product Operations
27101 Airport Road • Punta Gorda, Florida 33982
(941) 575-3800 • FAX (941) 575-4085 • FAX (800) 456-4085

Catalog No. EMP-003
PULSAtron and KOPkit are registered trademarks of Pulsafeeder.

Printed in U.S.A. 6/98