

3-2536-090-1  
B4/98

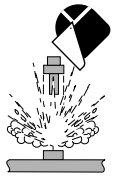

## SAFETY INSTRUCTIONS

1. Do not remove from pressurized lines.
2. Do not exceed maximum temperature/pressure specifications.
3. Do not install/service without following installation instructions (see sensor manual).
4. Wear safety goggles and face shield during installation/service.
5. Do not alter product construction.
6. Failure to follow safety instructions could result in severe personal injury!

## 1. Location of Fitting

Recommended sensor upstream/downstream mounting requirements.

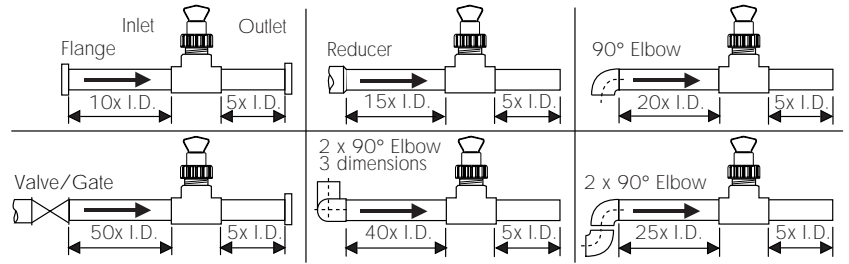

## 2. Sensor Mounting Position

- Horizontal pipe runs: Mount sensor in the upright (0°) position for best overall performance. Mount at a maximum of 45° when air bubbles are present. Do not mount on the bottom of the pipe when sediments are present.
- Vertical pipe runs: Sensor must be mounted in lines with UPWARD flow only.

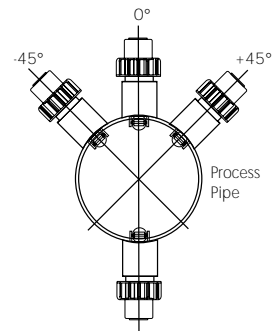

## 3. Sensor Wiring

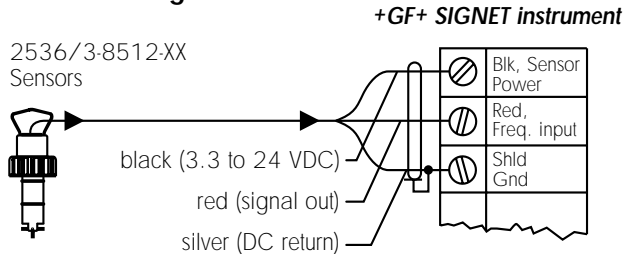

- Use 2-conductor shielded cable for cable extensions up to 300 m (1000 ft).
- Cable shield must be maintained through cable splice.
- +GF+ SIGNET Intelek-Pro, use 2536 input card setting
- Refer to you instrument manual for specific wiring details.

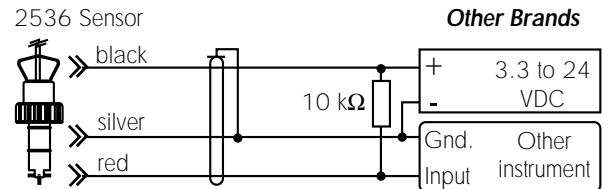

- Pull-up resistor required (10 kΩ recommended).
- Use 2-conductor shielded cable for cable extensions up to 300 m (1000 ft).
- Cable shield must be maintained through cable splice.

## 4. +GF+ SIGNET Fittings

Type	Description
Plastic tees 	<ul style="list-style-type: none"> <li>• 0.5 to 4 in. versions</li> <li>• PVC or CPVC</li> <li>• Mounts via glue-on fittings</li> </ul>
PVC glue-on saddles (O-ring not required) 	<ul style="list-style-type: none"> <li>• 2 to 4 in., cut 1-7/16 in. hole in pipe</li> <li>• 6 to 8 in., cut 2-1/4 in. hole in pipe</li> <li>• Align wedge arrows with saddle arrows during assembly.</li> <li>• Pipes over 8 in., use iron saddle</li> </ul>
Iron strap-on saddles 	<ul style="list-style-type: none"> <li>• 2 to 4 in., cut 1-7/16 in. hole in pipe</li> <li>• Over 4 in., cut 2-1/4 in. hole in pipe</li> <li>• Special order over 12 in.</li> </ul>
Carbon steel weld-on weldolets 	<ul style="list-style-type: none"> <li>• 2 to 4 in., cut 1-7/16 in. hole in pipe</li> <li>• Over 4 in., cut 2-1/4 in. hole in pipe</li> <li>• Remove insert before welding</li> <li>• Installed by certified welder only</li> <li>• Special order over 12 in.</li> </ul>
Carbon steel threaded tees 	<ul style="list-style-type: none"> <li>• 0.5 to 2 in. versions</li> <li>• Mounts on threaded pipe ends</li> </ul>

Type	Description
	<p><b>Metric plastic saddle</b></p> <ul style="list-style-type: none"> <li>• For pipes DN 65 to 200 mm</li> <li>• Requires a 30 mm diam. hole in the pipe</li> <li>• Wedge and saddle arrows must match</li> </ul>
	<p><b>Metric wafer fitting</b></p> <ul style="list-style-type: none"> <li>• For pipes DN 65 to 200 mm</li> <li>• Follow the recommended installation guidelines</li> </ul>
	<p><b>Metric union fitting</b></p> <ul style="list-style-type: none"> <li>• For pipes from DN 15 to 50 mm</li> <li>• PP or PVDF</li> <li>• Follow the recommended installation guidelines</li> </ul>

## 5. H-Dimensions

The plastic sensor insert in the Weldolet fitting MUST be removed during the welding process. When reinstalled, it is important that the insert be threaded to the proper height ("H" dimension).

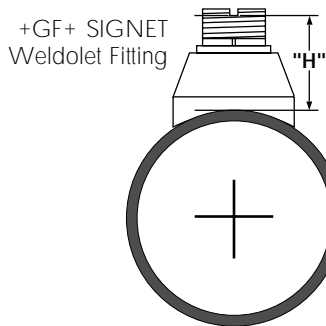

Weldolet part number	"H" dimension inches	"H" dimension mm	Weldolet part number	"H" dimension inches	"H" dimension mm
CS4W020	2.38	60.45	CS4W240	4.16	105.66
CS4W025	2.33	59.18	CS4W360	4.10	104.14
CS4W030	2.32	58.92			
CS4W040	2.30	58.42	CR4W020	2.38	60.45
CS4W050	3.09	78.48	CR4W025	2.33	59.18
CS4W060	2.96	75.18	CR4W030	2.32	58.92
CS4W080	2.73	69.34	CR4W040	2.30	58.42
CS4W100	5.48	139.19	CR4W050	3.09	78.48
CS4W120	5.25	133.35	CR4W060	2.96	75.18
CS4W140	5.10	129.54	CR4W080	2.73	69.34
CS4W160	4.85	123.19	CR4W100	5.48	139.19
CS4W180	4.60	116.84	CR4W120	5.25	133.35
CS4W200	4.38	111.25			

## 6. Standard Sensor Installation

- Lubricate the sensor O-rings with a silicone lubricant (e.g. GE silicone compound #G632 or equivalent). Do not use any petroleum based lubricant that will attack the O-rings.
- Using an alternating/twisting motion, lower the sensor into the fitting, making sure the installation arrows on the black cap are pointing in the direction of flow, **see Figure A.**
- Engage one thread of the sensor cap then turn the sensor until the alignment tab is seated in the fitting notch. **Hand tighten the sensor cap. DO NOT** use any tools on the sensor cap or the cap threads and/or fitting flange threads will be damaged, **see Figure B.**

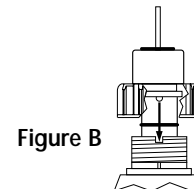
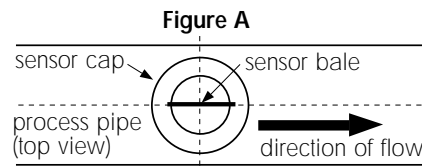

## 7. K-Factors

The **K-Factor** is the number of pulses the sensor will generate for each engineering unit of fluid which passes. They are listed in U.S. gallons and in liters. For example, in a 1 inch PVC pipe, the paddlewheel generates 352.435 pulses per gallon of fluid passing the rotor. K-Factors are listed for pipes up to 12 inch. For pipes over 12 inch, consult your +GF+ SIGNET distributor.

PIPE SIZE	+GF+ SIGNET FITTING TYPE	---K-FACTOR---	
		U.S. GAL	LITERS
<b>SCH 80 PVC TEES FOR SCH 80 PVC PIPE</b>			
1/2 IN.	PV8T005	991.706	262.010
3/4 IN.	PV8T007	545.142	144.027
1 IN.	PV8T010	352.435	93.114
1 1/4 IN.	PV8T012	177.184	46.812
1 1/2 IN.	PV8T015	117.852	31.137
2 IN.	PV8T020	66.739	17.633
2 1/2 IN.	PV8T025	42.994	11.359
3 IN.	PV8T030	26.652	7.041
4 IN.	PV8T040	15.006	3.964
<b>SCH 80 CPVC TEES FOR SCH 80 CPVC PIPE</b>			
1/2 IN.	CPV8T005	991.706	262.010
3/4 IN.	CPV8T007	545.142	144.027
1 IN.	CPV8T010	352.435	93.114
1 1/4 IN.	CPV8T012	177.184	46.812
1 1/2 IN.	CPV8T015	117.852	31.137
<b>SCH 80 PVC SADDLES ON SCH 80 PVC PIPE</b>			
2 IN.	PV8S020	66.739	17.633
2 1/2 IN.	PV8S025	42.994	11.359
3 IN.	PV8S030	26.652	7.041
4 IN.	PV8S040	15.006	3.964
6 IN.	PV8S060	8.325	2.199
8 IN.	PV8S080	5.016	1.325
<b>SCH 80 PVC SADDLE ON SCH 40 PVC PIPE</b>			
2 IN.	PV8S020	54.700	14.452
2 1/2 IN.	PV8S025	37.159	9.817
3 IN.	PV8S030	23.697	6.261
4 IN.	PV8S040	13.456	3.555
6 IN.	PV8S060	7.459	1.971
8 IN.	PV8S080	4.529	1.197
<b>CARBON STEEL TEES ON SCH 40 PIPE</b>			
1/2 IN.	CS4T005	756.000	199.736
3/4 IN.	CS4T007	438.690	115.902
1 IN.	CS4T010	286.784	75.768
1 1/4 IN.	CS4T012	121.218	32.026
1 1/2 IN.	CS4T015	91.139	24.079
2 IN.	CS4T020	54.468	14.391
<b>STAINLESS STEEL TEES ON SCH 40 PIPE</b>			
1/2 IN.	CR4T005	734.200	193.976
3/4 IN.	CR4T007	412.100	108.877
1 IN.	CR4T010	252.700	66.764
1 1/4 IN.	CR4T012	128.120	33.849
1 1/2 IN.	CR4T015	77.320	20.428
2 IN.	CR4T020	45.780	12.095

PIPE SIZE	+GF+ SIGNET FITTING TYPE	---K-FACTOR---	
		U.S. GAL	LITERS
<b>GALVANIZED IRON TEES ON SCH 40 PIPE</b>			
1 IN.	IR4T010	213.009	56.277
1 1/4 IN.	IR4T012	127.746	33.751
1 1/2 IN.	IR4T015	94.401	24.941
2 IN.	IR4T020	59.420	15.699
<b>CARBON STEEL WELDOLETS ON SCH 40 PIPE</b>			
2 1/2 IN.	CS4W025	37.600	9.934
3 IN.	CS4W030	24.340	6.431
4 IN.	CS4W040	13.920	3.678
5 IN.	CS4W050	10.860	2.869
6 IN.	CS4W060	7.520	1.987
8 IN.	CS4W080	4.340	1.147
10 IN.	CS4W100	2.760	0.729
12 IN.	CS4W120	1.940	0.513
<b>STAINLESS STEEL WELDOLETS ON SCH 40 PIPE</b>			
2 1/2 IN.	CR4W025	37.600	9.934
3 IN.	CR4W030	24.340	6.431
4 IN.	CR4W040	13.920	3.678
5 IN.	CR4W050	10.860	2.869
6 IN.	CR4W060	7.520	1.987
8 IN.	CR4W080	4.340	1.147
10 IN.	CR4W100	2.760	0.729
12 IN.	CR4W120	1.940	0.513
<b>SCH 80 IRON SADDLES ON SCH 80 PIPE</b>			
2 IN.	IR8S020	64.720	17.099
2 1/2 IN.	IR8S025	42.480	11.223
3 IN.	IR8S030	26.420	6.980
4 IN.	IR8S040	14.700	3.884
5 IN.	IR8S050	12.180	3.218
6 IN.	IR8S060	8.440	2.230
8 IN.	IR8S080	4.900	1.295
10 IN.	IR8S100	3.060	0.808
12 IN.	IR8S120	2.160	0.571
<b>SCH 80 IRON SADDLE ON SCH 40 PIPE</b>			
2 IN.	IR8S020	53.640	14.172
2 1/2 IN.	IR8S025	37.600	9.934
3 IN.	IR8S030	23.220	6.135
4 IN.	IR8S040	13.260	3.503
5 IN.	IR8S050	11.040	2.917
6 IN.	IR8S060	7.240	1.913
8 IN.	IR8S080	4.400	1.162
10 IN.	IR8S100	2.800	0.740
12 IN.	IR8S120	1.980	0.523

PIPE SIZE	+GF+ SIGNET FITTING TYPE	---K-FACTOR---	
		U.S. GAL	LITERS
<b>COPPER/BRONZE BRAZOLETS ON SCH 40 PIPE</b>			
2 1/2 IN.	BR4B025	37.600	9.934
3 IN.	BR4B030	24.340	6.431
4 IN.	BR4B040	13.920	3.678
5 IN.	BR4B050	10.860	2.869
6 IN.	BR4B060	7.520	1.987
8 IN.	BR4B080	4.340	1.147
10 IN.	BR4B100	2.760	0.729
12 IN.	BR4B120	1.940	0.513
<b>BRONZE TEES ON SCH 40 PIPE</b>			
1 IN.	BR4T010	213.009	56.277
1 1/4 IN.	BR4T012	127.746	33.751
1 1/2 IN.	BR4T015	94.401	24.941
2 IN.	BR4T020	59.420	15.699
<b>COPPER PIPE W/COPPER INSTALLATION FITTINGS</b>			
1/2 IN. SK K	CUKT005	917.844	242.495
1/2 IN. SK L		858.217	226.742
3/4 IN. SK K	CUKT007	428.270	113.149
3/4 IN. SK L		385.737	101.912
1 IN. SK K	CUKT010	256.430	67.749
1 IN. SK L		241.639	63.841
1 1/4 IN. SK K	CUKT012	176.437	46.615
1 1/4 IN. SK L		170.902	45.152
1 1/2 IN. SK K	CUKT015	115.690	30.565
1 1/2 IN. SK L		112.030	29.598
2 IN. SK K	CUKT020	63.385	16.746
2 IN. SK L		61.735	16.310

### Conversion Formulas:

1 U.S. gallon = 0.003785 cubic meters  
 0.000003069 Acre feet  
 8.3454 pounds of water

## K-Factors DIN Pipes

PIPE SIZE	+GF+ SIGNET FITTING TYPE	---K-FACTOR---		CODE	PIPE SIZE	+GF+ SIGNET FITTING TYPE	---K-FACTOR---		CODE
		U.S. GAL	LITER				U.S. GAL	LITER	
<b>POLYPROPYLENE FITTINGS (DIN/ISO AND BS AND ANSI)</b>					<b>PVC FITTINGS (DIN/ISO) - EUROPE ONLY</b>				
DN 15	PPMT005	952.870	251.749	198.150.522	DN 15	PVMT005	972.366	256.900	198.150.480
DN 20	PPMT007	563.100	148.771	198.150.523	DN 20	PVMT007	485.691	128.320	198.150.481
DN 25	PPMT010	291.604	77.042	198.150.524	DN 25	PVMT010	297.274	78.540	198.150.482
DN 32	PPMT012	169.222	44.709	198.150.525	DN 32	PVMT012	170.249	44.980	198.150.483
DN 40	PPMT015	103.897	27.450	198.150.526	DN 40	PVMT015	103.709	27.400	198.150.484
DN 50	PPMT020	60.789	16.060	198.150.527	DN 50	PVMT020	59.500	15.720	198.150.485
DN 65	PPMT025	41.498	10.964	198.150.560	DN 65	PVMT025	34.973	9.240	198.150.538
DN 80	PPMT030	26.786	7.077	198.150.561	DN 80	PVMT030	24.981	6.600	198.150.539
DN 100	PPMT040	17.415	4.601	198.150.562	DN 100	PVMT040	16.275	4.300	198.150.540
DN 125	PPMT050	10.168	2.686	198.150.563	DN 150	PVMT060	8.176	2.160	198.150.543
DN 150	PPMT060	7.312	1.932	198.150.564	DN 200	PVMT080	4.088	1.080	198.150.545
DN 200	PPMT080	3.995	1.055	198.150.565					
<b>PVDF FITTINGS (DIN/ISO AND BS AND ANSI)</b>									
DN 15	SFMT005	827.257	218.562	198.150.529					
DN 20	SFMT007	489.869	129.424	198.150.530					
DN 25	SFMT010	283.554	74.915	198.150.531					
DN 32	SFMT012	158.588	41.899	198.150.532					
DN 40	SFMT015	86.980	22.980	198.150.533					
DN 50	SFMT020	50.385	13.312	198.150.534					
DN 65	SFMT025	36.133	9.546	198.150.571					
DN 80	SFMT030	24.715	6.530	198.150.572					
DN 100	SFMT040	16.120	4.259	198.150.573					
DN 125	SFMT050	8.862	2.341	198.150.574					
DN 150	SFMT060	6.454	1.705	198.150.575					
DN 200	SFMT080	4.072	1.076	198.150.576					

## 8. Order Information

Standard 2536 Low Flow Sensors						All O-rings are Viton®						+GF+ SIGNET 3-8512-XX Integral Sensor Accessories					
Order No.	Housing	Rotor Pin	Rotor	Pipe Size	Code	Order No.	Description				Code	Order No.	Description				Code
3-2536-PO	Polypro.	Titanium	PVDF (black)	0.5 to 4.0 in.	198 840 143	3-8011	Integral sensor mounting kit with 1/2 in. NPT ports				198 864 500	3-8011-D	Integral sensor mounting kit with PG13.5/DIN ports				198 864 501
3-2536-P1	Polypro.	Titanium	PVDF (black)	5.0 to 8.0 in.	198 840 144	+GF+ SIGNET 3-8512-XX Integral Sensors						All O-rings are Viton®					
3-2536-P2	Polypro.	Titanium	PVDF (black)	10 to 36 in.	198 840 145	Order No.	Housing	Rotor Pin	Rotor	Pipe Size	Code	3-8512-PO	Polypro.	Titanium	PVDF (black)	0.5 to 4.0 in.	198 864 513
3-2536-V0	PVDF (natural)	Hastelloy C	PVDF (natural)	0.5 to 4.0 in.	198 840 146	3-8512-P1	Polypro.	Titanium	PVDF (black)	5.0 to 8.0 in.	198 864 514	3-8512-V0	PVDF (natural)	Hastelloy C	PVDF (natural)	0.5 to 4.0 in.	198 864 516
3-2536-V1	PVDF (natural)	Hastelloy C	PVDF (natural)	5.0 to 8.0 in.	198 840 147	3-8512-T0	PVDF (natural)	PVDF (natural)	PVDF (natural)	0.5 to 4.0 in.	198 864 518						
3-2536-T0	PVDF (natural)	PVDF (natural)	PVDF (natural)	0.5 to 4.0 in.	198 840 149												
<b>Accessories</b>																	
Order No.			Order No.			Order No.	Rotor Pin	Material	Code			Order No.	Description				Code
3-2536-320	PVDF (black)	198 820 052	M1546-1	Titanium	198 801 182	3-2536-321	PVDF (natural)	198 820 054	M1546-2	Hastelloy C	198 801 183	P31542-2	Sensor cap, PP				198 840 232
3-2536-321	PVDF (natural)	198 820 054	M1546-3	Tantalum	198 820 014				M1546-4	316 SS	198 820 015	P31536	Plug, PP				198 840 201
			P51545	Ceramic	198 820 016				3-2536-321	PVDF (natural)	198 820 054	P31536-2	Plug, PVDF with std. cap				198 840 202
Order No.																	
O-Rings	Material	Code															
1220-0021	Viton® (std.)	198 801 186															
1224-0021	EPR	198 820 006															
1228-0021	Kalrez	198 820 007															

## 9. Rotor Replacement Procedure

- To remove the rotor, insert a small screwdriver between the rotor and the ear of the sensor.
- Twist the screwdriver blade to flex the ear outward enough to remove one end of the rotor and pin. **DO NOT** flex the ear any more than necessary! If it breaks, the sensor cannot be repaired.
- Install the new rotor by inserting one ear into the hole, then flex the opposite ear back enough to slip rotor into place.

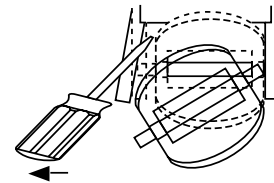

## 10. Specifications

### General Data

Flow rate range: 0.1 to 6 m/s (0.3 to 20 ft/s)  
 Linearity:  $\pm 1\%$  of full range  
 Repeatability:  $\pm 0.5\%$  of full range

Pipe size range:  
 • 2536 Sensor: 15 to 900 mm (0.5 to 36 in.)  
 • 3-8512-XX Sensor: 15 to 200 mm (0.5 to 8 in.)

Cable length (2536): 7.6 m (25 ft), can splice up to 300 m (1000 ft)

Cable type: 2-conductor twisted-pair with shield

### Materials

Sensor assembly: Various thermoplastics available. Refer to section 8 for details.

### Electrical

Supply voltage: 3.3 to 24 VDC regulated  
 Supply current:  $< 1.5$  mA @ 3.3 - 6 VDC,  
 $< 20$  mA @ 6 - 24 VDC

Output type: Open collector transistor, sinking  
 Output current: 10 mA max.

### Quality Standards

- CE
- Manufactured under ISO 9001

### Fluid Conditions

Pressure/Temperature Ratings

Polypropylene Body:

- 12.5 bar (180 psi) max. @ 20 °C (68 °F)
- 1.7 bar (25 psi) max. @ 85 °C (185 °F)

PVDF Body:

- 14 bar (200 psi) max @ 20 °C (68 °F)
- 1.7 bar (25 psi) max @ 85 °C (185 °F)

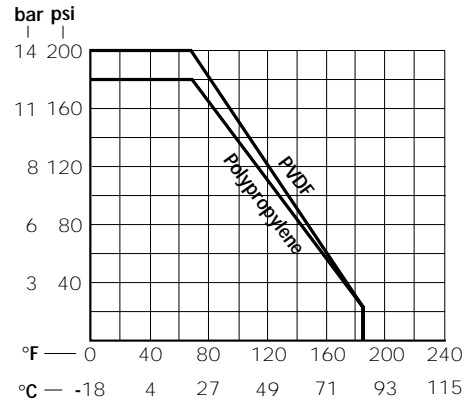

### 2536 Dimensions

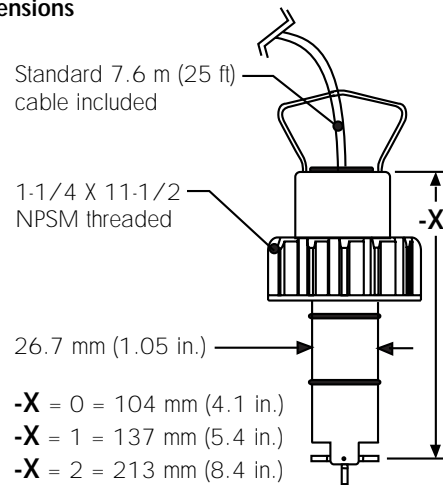

The last digit (X) in the sensor's part number represents the sensor's overall length

## +GF+ SIGNET

### Sales Offices:

**USA** George Fischer, Inc., 2882 Dow Avenue, Tustin, CA 92780/USA, Tel. (714) 731-8800, Fax (714) 731-6201  
**Switzerland** Georg Fischer Rohrleitungssysteme AG, P.O. Box 671, CH-8201 Schaffhausen/Switzerland, Tel. 052/631 1111, Fax 052/631 2830  
**Singapore** George Fischer Pte. Ltd., 15 Kaki Bukit Road 2, KB Warehouse Complex, Singapore 1441, Tel. 65/747 0611, Fax 65/747 0577  
**Japan** Kubota George Fischer, 2-47 Shikitsuhigashi, 1-Chome, Naniwa-Ku, Osaka, 556-91 Japan, Tel. 816/648 2545, Fax 816/648 2565  
**China** Georg Fischer Ltd., Rm 1503, Business Residence Bldg. of Asia Plaza, 2-3 Bldg. No. 5th Qu Anzhenxili, Chaoyang Qu, Beijing 100029, P.R. China, Tel. 86/10 6443 0577, Fax 86/10 6443 0578  
**Australia** George Fischer Pty. Ltd., Suite 3, 41 Stamford Road, Oakleigh, Victoria 3166, Australia, Tel. 61/3 9568 0966, Fax 61/3 9568 0988

Signet Scientific Company, 3401 Aerojet Avenue, El Monte, CA 91731-2882 U.S.A., Tel. (626) 571-2770, Fax (626) 573-2057

GEORGE FISCHER +GF+ Piping Systems

3-2536.090-1/(B-4/98), English

© Signet Scientific Company 1996



PRINTED ON RECYCLED PAPER

Printed in U.S.A.