

+GF+ SIGNET 2550 Insertion Magmeter

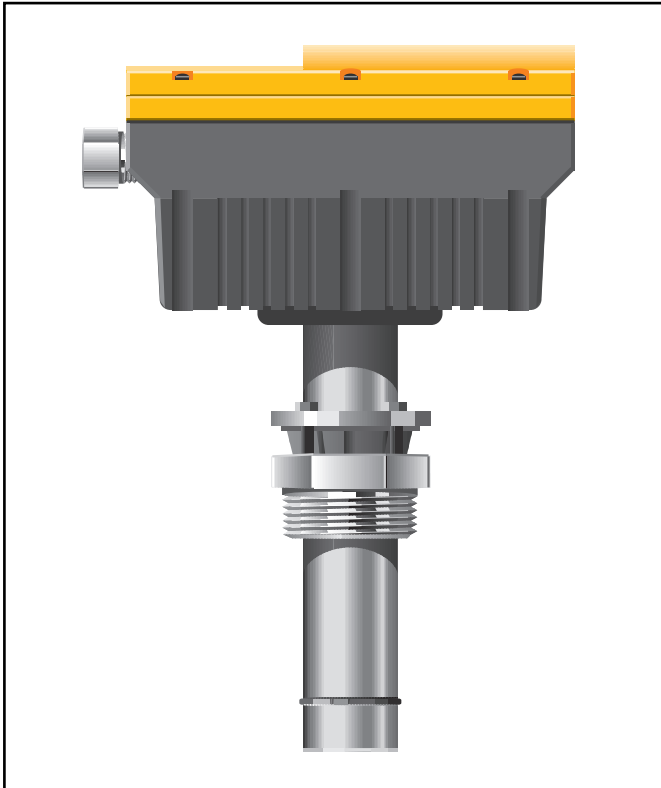

Instruction Manual

GEORGE FISCHER +GF+

Important Safety Information!

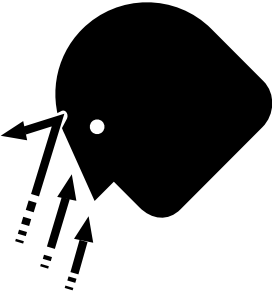

CAUTION: Do not remove from pressurized lines!
Do not remove safety ring from sensor. Unit may become a dangerous projectile if safety devices are disabled.



Do not open wiring access plate in humid environment. Moisture in terminal area may cause instrument failure.



In EDIT mode, all the output functions of the +GF+ SIGNET 2550 Insertion Magmeter are still active, so the control process is uninterrupted.



The +GF+ SIGNET 2550 Insertion Magmeter weighs 11 lbs. Care must be taken to properly support the unit with straps and/or bracing when necessary.

	Page	Table of Contents
Chapter 1		
Introduction	1	
1.1 Description	1	
Chapter 2		
Installation and wiring	2	
2.1 Sensor location	2	
2.2 Preparing the pipe	2	
2.3 Sensor installation with tool	3	
2.4 Sensor installation without tool	4	
2.5 Wiring	5	
2.6 Grounding requirements	6	
2.7 Installation tips	7	
Chapter 3		
Operation	8	
3.1 Control panel description	8	
3.2 Main menu	9	
3.2.1 Access code	10	
3.3 Calibrate functions	10	
3.3.1 Unit	11	
3.3.2 Interior diameter	12	
3.3.3 Current output	13	
3.4 Performance functions	14	
3.4.1 Sensitivity	14	
3.4.2 Response time	15	
3.4.3 Viscosity	16	
3.4.4 AC noise filter	16	
3.4.5 Calibration "B"	17	
3.5 Display options	18	
3.5.1 Operational outputs	18	
3.5.2 Diagnostic displays	19	
3.6 Frequency output	20	
3.6.1 Product compatibility	20	
3.7 Calibration data	20	
3.8 Custom K-factor calculation	23	
3.9 Spare parts list	24	
Specifications	25	
Warranty Information	28	

Unpacking and Inspection

The +GF+ SIGNET 2550 Insertion Magmeter package includes the following items:

- 3-2550.100 sensor
- 3-2550.090 instruction manual
- 3-2550.355 installation tool (optional)

Please fill out and return the warranty card as soon as possible.

The technical information given in this manual is for general information only. It implies no warranty of any kind.

Warranty record

For your protection, record the purchase information for future reference. The serial number decal is located on the sensor, and also inside the wiring access plate.

**Model: +GF+ SIGNET 2550 Insertion
Magmeter**

Purchase date: _____

Serial number: _____

Purchased from: _____

Purchase order number: _____

This manual contains descriptions, specifications, and instructions for the installation and operation of the +GF+ SIGNET 2550 Insertion Magmeter. Should you require further assistance, please contact your Signet supplier.

Chapter 1

Introduction

1.1 Description

The latest in bipolar pulsed DC technology and the best features of an insertion sensor are packed into the +GF+ SIGNET 2550 Insertion Magmeter. Simple installation, easy maintenance, and state-of-the-art microprocessor technology make the 2550 the best alternative to traditional full-line magmeters.

The 2550 is based on the Faraday principle, and provides current frequency output signals proportional to the flow rate. The system incorporates automatic temperature compensation, resulting in outputs that are accurate within $\pm 2\%$ of actual flow rate.

The bipolar electronic design and the $10000\text{ M}\Omega$ input impedance reduce galvanic formation on the electrodes and minimize coating problems.

The isolated current output provides an universal signal to recorders, valves, process control and data acquisition devices.

The open collector frequency output is compatible with all powered flow controllers such as the +GF+ SIGNET 9010 Inteltek-Pro Flow Controller.

See Section 3.9 for an exploded view of the 2550.

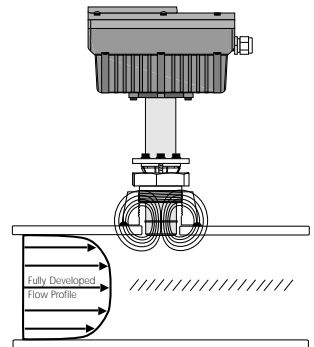

Faraday's Principle: Movement of a conductive fluid through a magnetic field generates a perpendicular electromotive force proportional to its velocity.

Chapter 2

Installation and wiring

The linearity and accuracy of the 2550 depend on precise alignment and insertion depth of the sensor in the pipe and accurate measurement of the pipe dimensions. The installation tool (3-2550.355) is recommended for best results.

2.1 Sensor location

Select a location for the sensor where the flow profile is fully developed and not affected by any disturbances. A minimum of 10 pipe diameters of straight run upstream and 5 diameters downstream is recommended. Some situations may require 20 pipe diameters or more upstream to insure a fully developed turbulent flow profile.

The 2550 is sensitive to air bubbles at the electrodes. If there is any question that the pipe is absolutely full, mount the sensor at a 45 to 135° angle. The magmeter requires a clearance of approximately 16 in./400 mm for removal.

2.2 Preparing the pipe

1. Cut a 2.125 in. $\pm 1/16$ in. (54 mm ± 1.6 mm) opening in the pipe. Carefully debur the hole for best results.
2. Install a standard 2 in. saddle or weld-on fitting on the pipe. Welded fittings should be installed by qualified personnel. The threads must be perpendicular to the pipe within 1° for proper performance.

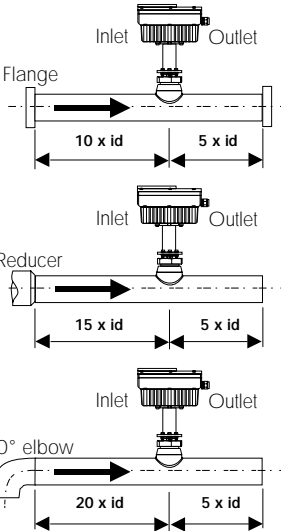

Measure and record the interior diameter of the pipe. This value will be required to calibrate the 2550.

Interior diameter:

2.3 Sensor Installation with tool

The installation tool (3-2550.355) simplifies installation and insures proper insertion depth for maximum accuracy.

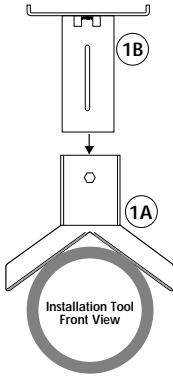

1. Set installation tool angle plate (1A) on pipe next to fitting. Insert adjusting slide (1B) into top of angle plate.

2. Place height gauge (2A) short end inside pipe and pull up against inside diameter of pipe. Insert height gauge long end into slot in adjusting slide. Tighten wing nut (2B) to hold adjusting slide in place against angle plate. Remove height gauge from pipe.

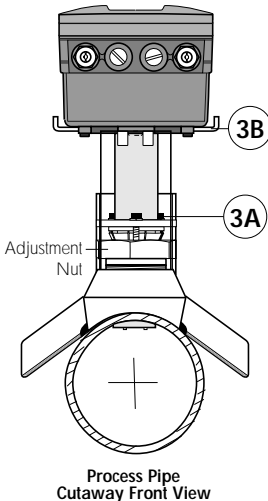

3. Loosen the three bolts at top of 2550 adjustment nut (3A). Wrap the adjustment nut threads with three full wraps of Teflon tape and insert sensor into fitting until base of the electronics enclosure is resting on top of adjusting slide (3B). Be sure cable ports are pointing downstream. Thread adjustment nut securely into pipe. Tighten all three bolts to secure adjustment nut.

Important Safety Information!



Do not remove safety ring or adjustment nut from sensor.

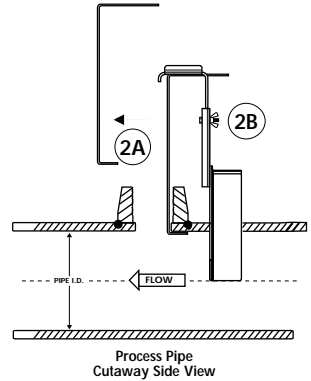

The 2550 Magmeter weighs 11 lbs. Care must be taken to properly support the unit with straps and/or bracing when necessary.

2.4 Sensor Installation without tool

It is recommended that the installation tool always be used when installing the 2550. If the installation tool is not available, follow the instructions below. Pay careful attention to the insertion depth of the sensor in the pipe and the alignment of the electrodes relative to the pipe.

Important Safety Information!



Do not remove safety ring or adjustment nut from sensor.



The 2550 Magmeter weighs 11 lbs. Care must be taken to properly support the unit with straps and/or bracing when necessary.

1. Loosen three bolts at top of 2550 adjustment nut. Wrap adjustment nut threads with 3 full wraps of Teflon tape and insert 2550 sensor into fitting. Be sure cable ports are pointing downstream. Thread adjustment nut securely into pipe.

2. Adjust meter height so tip of sensor is 0.20 inches below the inside diameter of pipe. Calculate the "H" dimension:

$$H = \text{sensor length} - 0.2 \text{ in} - \text{wall} = 8.1025 \text{ in.} - 0.2 \text{ in} - \text{wall}$$

$$H = 7.9025 - \text{wall}$$

$$(H = 200 \text{ mm} - \text{wall thickness})$$

3. Align the magmeter parallel with the pipe $\pm 1^\circ$. Retighten the three 3/16 in. bolts to secure the sensor in the pipe.

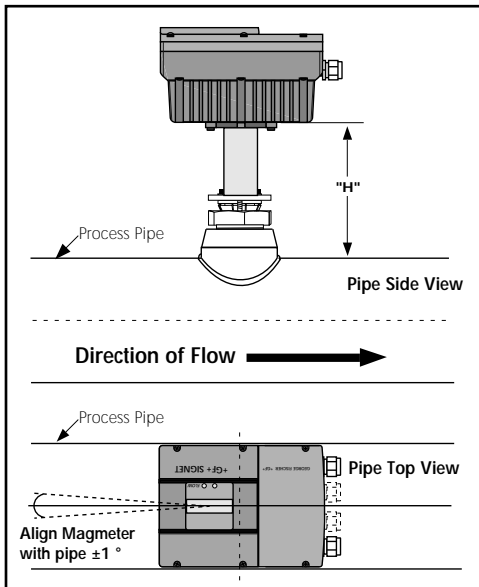

2.5 Wiring

To access the wiring terminals in the 2550 loosen six captive outer cover screws (1), lift off outer cover (2), then loosen two captive screws (3) and remove access plate (4). A wiring diagram is located on the inside of the access plate. Five terminal strips are available.

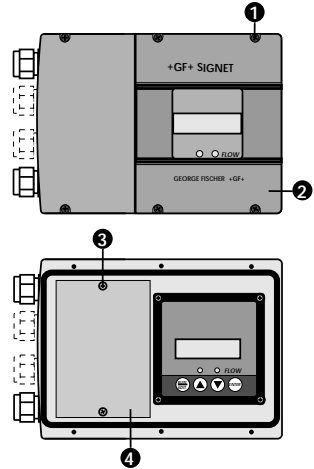

TS 3 Analog output

4 to 20 mA or 0 to 20 mA output
 terminal 1 positive (R+)
 terminal 2 negative (R-)
 18 to 22 AWG wire recommended.

TS4 Serial communication - future expansion not available in this model.

TS 2 Frequency output

terminal 1 black 5 to 12 VDC in
 terminal 2 red open collector pulse out
 terminal 3/4 shield cable shield/gnd
 see sec 3.4 for detailed information.
 18 to 22 AWG wire recommended.

TS 1 Power input

terminal 1 negative
 terminal 2 positive
 14 to 20 AWG wire recommended.
 Recommended power supply:
 Model no. HB24-1.2A (24 V @ 1.2 A)
 or equivalent
 Power-One, Inc., Camarillo, Ca. U.S.A.
 ph. 805/987-8741
 toll free 800/678-9445
 fax 805/388-0476

TS5 Case

chassis ground terminals; see sec 2.6.

All wiring is installed through the watertight ports in the meter. Wrap threads with Teflon tape before threading into sockets.

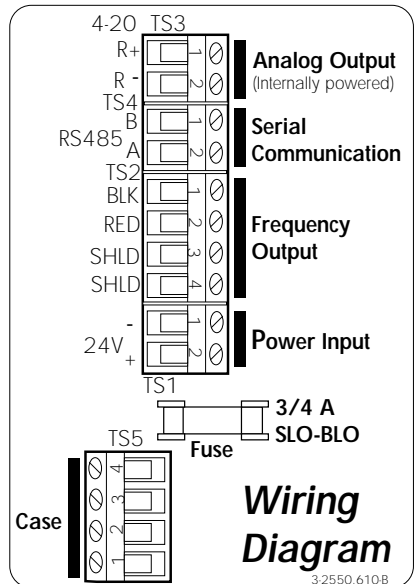

2.6 Grounding requirements

The 2550, like all magnetic flow sensors, is sensitive to electrical noise which is present in most piping systems. The grounding procedure illustrated below is necessary in all installations to insure proper performance.

Connect a local earth ground to the TS5 terminal strip as illustrated (EG1). If the cable from power source to the 2550 is less than 200 ft./61m, EG2 is an acceptable alternative. Using both EG1 and EG2 is always the best system.

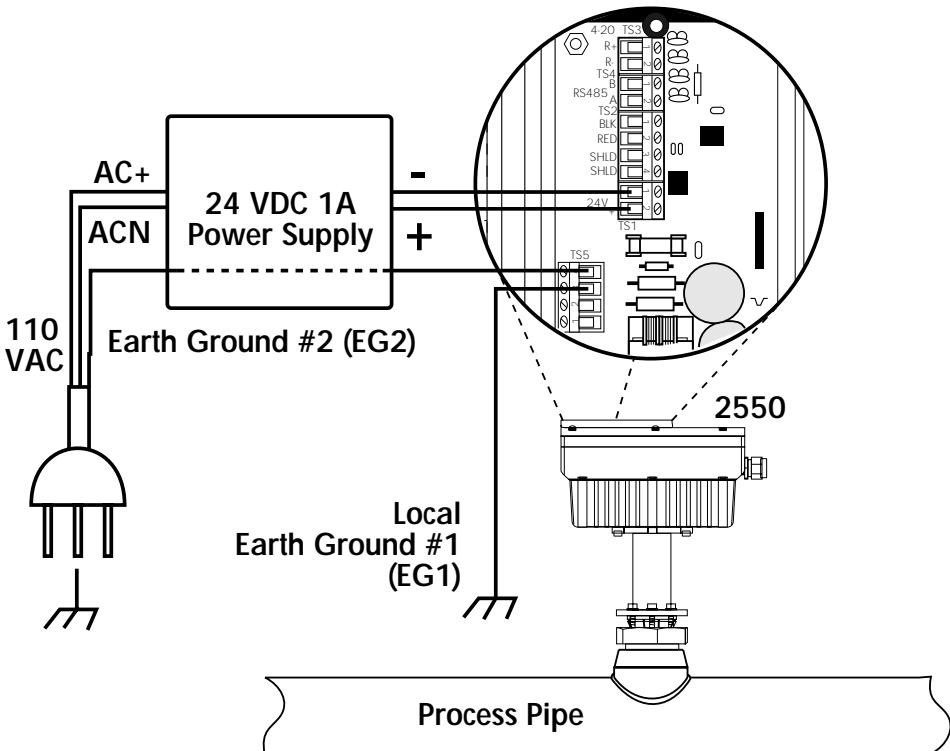

2.7 Installation tips

1. Make sure the Filter function is set to the proper value for your AC power source (50 or 60 Hz). (See sec 3.4.4)

2. Allow the magmeter to operate for a period before attempting to calibrate the unit. The electronics require a "settling" period during which the electrode may generate unstable signals. Thirty minutes to one hour is sufficient.

3. In plastic piping systems, the fluid carries significant levels of static electricity that must be grounded for best magmeter performance.

Since plastic pipe is not grounded as metal pipes are, extra steps must be taken. Identify the places where the fluid is in electrical contact with external metal structures or grounds. Connect these points to TS5 wherever practical.

4. Connect the 24 VDC power and the analog output signal cables through separate cable ports. If the frequency output is being used, install a watertight cable connector in one of the unused ports. Do not run two cables through one port. Doing so will defeat the watertight integrity of the port. (See sec 3.9, spare parts list)

Chapter 3



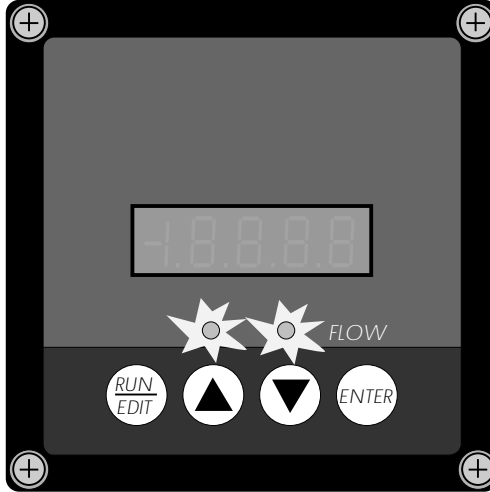

3.1 Control panel description

Operation

4 digit liquid crystal display:
"- - - - -" indicates
reverse flow. All signal
outputs are disabled.



*During EDIT mode, all the
output functions of the 2550
are still active, so the control
process is uninterrupted.*

- The  key switches the display from normal operation (RUN) to EDIT, where the calibration parameters can be modified.
- The  and  keys scroll through the menu selections and edit options.
- The  key serves two functions.
 1. Selects a particular item from main menu.
 2. Stores a new value in calibration functions.

Two lamps on the front panel provide a visual indication of system status:

Indication	steady green lamp:	normal operation
Indication	flashing green lamp:	noise level exceeds acceptable range; all outputs frozen at last value for 10 seconds.
Indication	flashing red lamp:	when intermittent flow is detected

3.2 Main menu







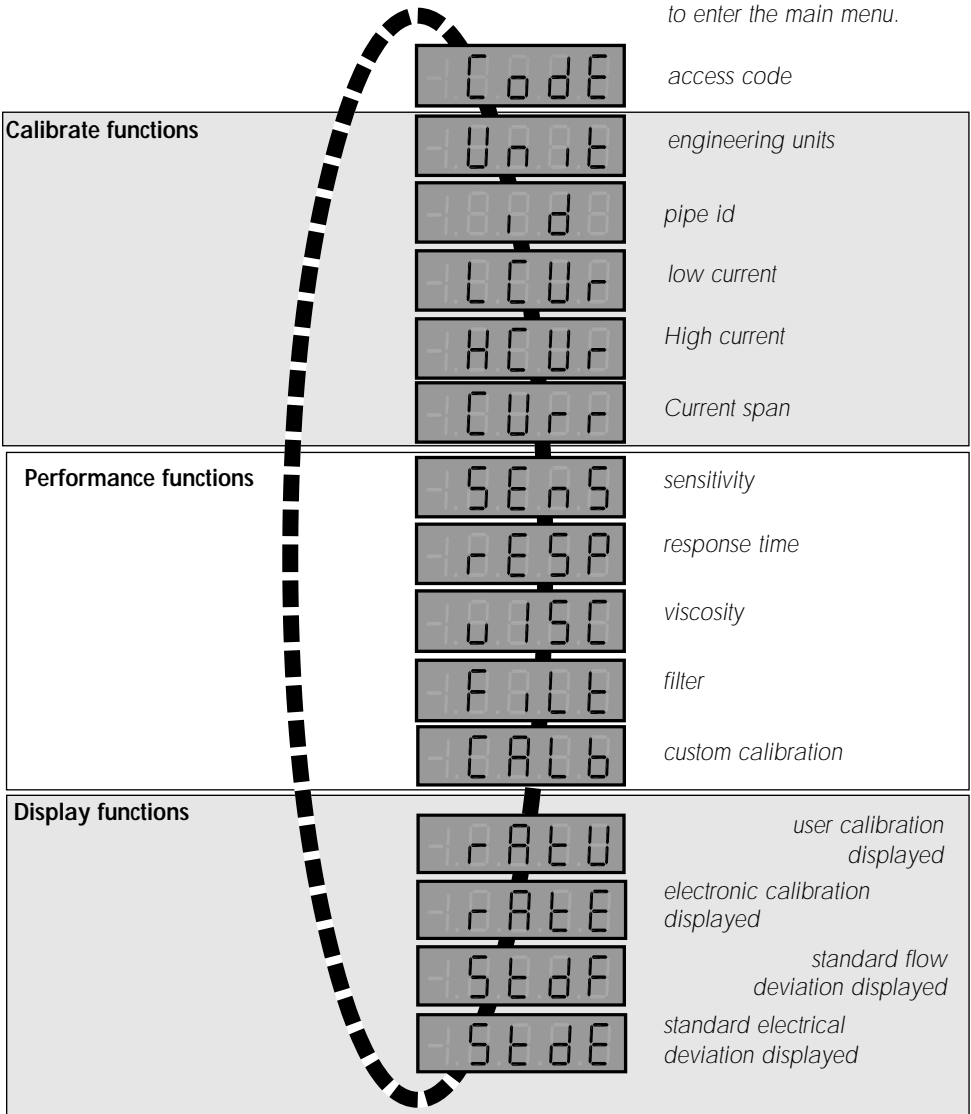



The menu is constructed in a loop, so you can move forward and backward to select an item. After any item is edited, the display will return to the main menu in the same location where it left off.



Press the run/edit key to enter the main menu.



THIS BASIC OPERATING PROCEDURE REPEATS THROUGHOUT THE 2550 PROGRAM:

1. PRESS  TO ENTER EDIT MENU.
2. PRESS  /  TO MOVE TO A SPECIFIC MENU ITEM.
3. PRESS  KEY TO SELECT THE ITEM FOR EDITING.
4. PRESS  /  /  TO EDIT THE VALUE/SELECTION.
5. PRESS  TO STORE THE NEW VALUE/SELECTION.
6. PRESS  /  TO SELECT ANOTHER MENU ITEM, OR
7. PRESS  TO RETURN TO NORMAL OPERATION.

3.2.1 Access code

The main menu begins with a preprogrammed access code of "1020" which allows editing of any menu setting.

Without entering the code, the menu settings can be viewed, but not edited.

Run/edit key displays first item in main edit menu.





















Enter selects item for editing.

Up arrow advances flashing digit.

Enter key stores the change and advances flashing digit.

Up arrow advances flashing digit.

Final Enter key returns display to main edit menu.

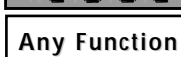
Step:	Press:	To display:
1.		
2.		
3.		
4.		
5.		
6.		
7.		
8.		
9.		
10.	 	

3.3 Calibrate functions

The next five main menu functions are used to input your specific application data. To edit menu items, enter code first. (See sec. 3.2.1 above)

3.3.1 Unit

Six engineering unit options are available in the unit menu. Select one for your flow rate display.

- m/s** Meters per second
- ft/s** Feet per second
- l/s** Liters per second
- l/min** Liters per minute
- GPM** U.S. Gallons per minute
- m³/h** Cubic meters per hour

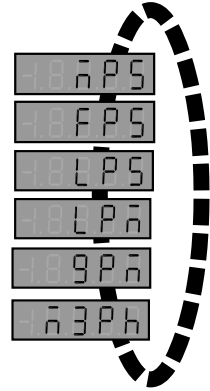

To change the engineering unit selection, first enter the access code (section 3.2.1) then press the down arrow until the display shows:



Step:

Press:

To display:

1.



2.



3.



Example illustrates changing engineering units from gallons per minute to liters per minute.

The factory default setting for Units is GPM

UP arrow key changes setting

ENTER key selects new setting and returns display to main menu.

Arrow keys advance main menu function;
run/edit key returns to normal operation.

3.3.2 Interior diameter

You must enter the precise interior diameter of your pipe as measured during the installation process. Entry is made in inches when the dimension entered is less than 40, and automatically switches to millimeters when the dimension entered is greater than 40.

The example illustrates setting id to 10.40 in.

To change the id selection, enter the access code (section 3.2.1) then press the down arrow until the display shows:



The factory default setting for id is 2.067 in.

Down arrow key changes flashing digit.

ENTER key stores new setting and advances flashing digit.

Down arrow key changes flashing digit.

Up arrow key changes flashing digit.

The decimal point location is selected after the last flashing digit is set.

Down arrow key moves decimal to right.

ENTER key stores final setting and returns to main menu.

Step:	Press:	To display:
1.		
2.		
3.		
4.		
5.		
6.		
7.		
8.		
9.		
10.		
11.		
12.		
13.		

Arrow keys advance main menu function;
run/edit key returns to normal operation.

3.3.3 Current output

The current output of the 2550 is set via three settings. **Low current** specifies the flow rate represented by the minimum current signal (4 or 0 mA). **High current** is the flow rate represented by the maximum current (20 mA), and **current** selects a 4 to 20 or a 0 to 20 mA span.

To change the current selections, first enter the access code (section 3.2.1) then press the down arrow until the display shows:



Step:	Press:	To display:
1.		0000
2.		0000
3.		0000
4.		0000
5.		LCUR
6.		HCUR
7.		200.0
8.		300.0
9.		3000
10.		3000
11.		3000
12.		3000
13.		HCUR
14.		CURr
15.		4-20
16.		0-20
17.		CURr

Example illustrates setting current output for 0 to 300 GPM = 4 - 20 mA.

**The factory default value for current is :
0 to 200 GPM = 4 - 20 mA.**

Down arrow advances to next menu item.

Up arrow changes flashing digit.

Press enter 5 times to store the new setting and return to main menu.

Down arrow advances to next menu item.

Arrow keys will toggle setting.

Enter key stores final setting and returns to main menu.

Arrow keys advance main menu function;
run/edit key returns to normal operation.

3.4 Performance functions

The next five main menu functions help to tailor the magmeter signals to your specific environment.

3.4.1 Sensitivity

The sensitivity function limits the amount of reference level noise detected by the Magmeter input circuit. Use the StdE display (sec 3.5.2) to evaluate the amount of reference noise in your system. If StdE is greater than 0.05, decreasing the sensitivity value may stabilize flow readings.

The range selections are from 1 to 10, with 1 representing the most sensitive and 10 the least sensitive.

To change the sensitivity setting, first enter the access code (section 3.2.1) then press the down arrow until the display shows:

Example illustrates changing sensitivity setting to 6.

The factory default setting for sensitivity is 4.

Up arrow changes the setting.

The enter key stores the new setting and returns the display to the main menu.

Step:	Press:	To display:
1.		
2.		
3.		
4.		

Arrow keys advance to another menu function;
run/edit key returns to normal operation.

3.4.2 Response time

The response time function varies the rate at which the output functions adjust to changes in the input signal. For example, if the response time is set at 10 seconds, the current output will take ten seconds to reflect 95% of any change in flow signal input .

Use the response time to reduce the effects of turbulence and steady/periodic noise in the flow. The standard flow deviation display (sec. 3.5.2) will help evaluate the need for increased response time. The options available are Instantaneous, 5, 10, 15, 20, 30, 40, 60, or 80 seconds.

To change the response time setting, first enter the access code (section 3.2.1) then press the down arrow until the display shows:



Example illustrates setting response at 20 seconds.

Step:

Press:

To display:

1.



The factory default setting for response is 10 seconds.

2.



Up arrow changes the setting.

3.



The enter key stores the new setting and returns the display to the main menu.

4.



Arrow keys advance to another menu function;
run/edit key returns to normal operation.

Viscosity ranges

1 = 1 cp
water

2 = 2 cp

3 = 4 cp

4 = 8 cp

5 = N/A- future expansion

3.4.3 Viscosity

Viscosity changes affect the flow profile in the pipe, and can compromise the accuracy of the 2550. This function allows you to compensate for viscosity. Select a viscosity setting from 1 to 4. 1 represents water, and 2 through 4 represent increasingly viscous fluids.

To change the viscosity setting, first enter the access code (section 3.2.1) then press the down arrow until the display shows:

Step: **Press:** **To display:**

- | | | |
|----|--|--|
| 1. | | |
| 2. | | |
| 3. | | |

Arrow keys advance main menu function;
run/edit key returns to normal operation.

3.4.4 AC noise filter

Select 50 Hz or 60 Hz rejection filter according to the AC power standard in your area.

To change the filter setting, first enter the access code (section 3.2.1) then press the down arrow until the display shows:

- | | | |
|--------------|---------------|--------------------|
| Step: | Press: | To display: |
| 1. | | |
| 2. | | |
| 3. | | |

Arrow keys advance main menu function;
run/edit key returns to normal operation.

The factory default setting for viscosity is 1.

Press the up arrow to change the setting to 2.

The enter key stores the new setting and returns to the main menu.

The factory default setting for AC filter is 60 cycles.

Press the up or down arrow to change the setting.

The enter key stores the new setting and returns to the main menu.

3.4.5 Calibration "B"

The CalB function allows you to compare the 2550 calibration to your own volumetric or alternate flow measurement system. The 2550 stores this flow rate under the display function RatU (sec. 3.5.1).

Calculate the flow rate by measuring the volume output for a fixed time period.
volume ÷ time = flow rate

The calibration based on the pipe data is still stored in the memory, and can be recalled by selecting the display function RatE (sec 3.5.1).

To use CalB, first enter the access code (section 3.2.1) then use the arrow keys until the display shows:

Step:	Press:	To display:	
1.			<i>This is current display selection RatE (see sec 3.5.1)</i>
2.			
3.			<i>Now the display has a flashing digit.</i>
4.			
5.			
6.			<i>Use the ENTER, UP and DOWN arrow keys to set the new flow rate.</i>
7.			
8.			<i>When completed, the new calibration is stored as RatU. (sec 3.5.1)</i>
9.			
10.			<i>Press the ENTER key to display RatU value.</i>

Recall the original calibration by selecting RatE (See section 3.5.1).

3.5 Display options

The last four main menu functions change the displayed information. The first two also change the output values.

3.5.1 Operational outputs

The "Rate Electronic" and "Rate User" functions change both the display and the output values in the magmeter.

- RatE selects the standard calibration value based on entered pipe id as the basis for all outputs.
- RatU selects the "Cal B" value as the basis for all outputs.

Code entry is not necessary to change the display setting.

RatE is the factory default setting.

Example illustrates changing display setting to StdE.

Use the up arrow to move quickly to the display options.

The display and all outputs adjust to the new selection when the enter key is pressed.

Step:	Press:	To display:
1.		
2.		
3.		
4.		
5.		
6.		

3.5.2 Diagnostic displays

The diagnostic displays are used to evaluate abnormalities in the process stream.







- The **standard electrical deviation** (StdE) is related to the level of electrical fluctuation in the input signal reference. The value is displayed in terms of volts, ie "0.02" represents 20 millivolts. Nominal values range from 50 mV at low velocities to 80 mV at maximum velocity. Higher values indicate excessive fluid noise levels, or inadequate earth ground. Use the Sensitivity adjustment (sec 3.4.1) to compensate and check the grounding requirements (sec. 2.6).
- The **standard flow deviation** (StdF) is an overall indication of the stability of the flow signal. It incorporates the StdE, as well as mechanical factors such as unstable flow profiles, misaligned sensors, and coated electrodes. StdF is displayed as a percentage of flow rate, typically from 5 to 8%. StdF levels in excess of 10% indicate inadequate installation or application standards.

If StdE value is high, the StdF will always be high.

If StdE is low but StdF is high, look for causes related to sensor location, such as insufficient upstream straight runs and sensor alignment. If the StdF cannot be corrected by modifying the installation, the Response function (sec 3.4.2) will help to smooth the output signals.

Example illustrates changing display setting to StdE.

Code entry is not necessary to change the display setting.

Step:	Press:	To display:
1.		
2.		
3.		

*Use the up arrow to move quickly to the display options. **RatE** is the factory default setting.*

Selecting the StdE or StdF diagnostic displays will not affect or interrupt the outputs.

3.6 Frequency output

The frequency output from the 2550 is an open collector signal that requires a 5 to 12 VDC reference.

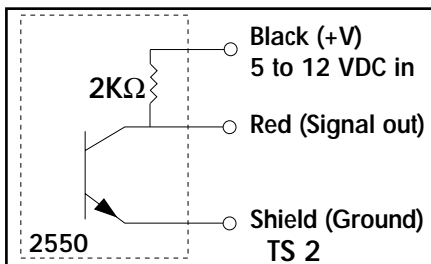

3.6.1 Product compatibility

The following +GF+ SIGNET instruments require the 3-2507.278 input module when driven from the 2550 frequency output:

504 511 514 527 575 578
579 584 585 9520

If using the +GF+ SIGNET 9010 flow controller, set input card switches for "1001" (5 VDC power to sensor with pull up resistor).

3.7 Calibration data

Pipe type	pipe size	pipe id	gpm/fps	lpm/fps	K pls/gal	A gpm/Hz	K pls/l	A lpm/Hz
U.S. pipe data								
PVC sched 80	2 in.	1.91	8.95858	33.912	167.44	0.36	44.23	1.36
PVC sched 40	2 in.	2.05	10.2576	38.829	146.23	0.41	38.63	1.55
steel sch 5S	2 in.	2.25	12.3379	46.704	121.58	0.49	32.12	1.87
steel sch 10S	2 in.	2.16	11.3896	43.115	131.70	0.46	34.79	1.72
steel sch 40S	2 in.	2.07	10.459	39.592	143.42	0.42	37.89	1.58
steel sch 80S	2 in.	1.94	9.20375	34.84	162.98	0.37	43.05	1.39
PVC sched 80	2.5 in.	2.29	12.8375	48.596	116.85	0.51	30.87	1.94
PVC sched 40	2.5 in.	2.45	14.6341	55.397	102.50	0.59	27.08	2.22
steel sch 5S	2.5 in.	2.71	17.965	68.005	83.50	0.72	22.06	2.72
steel sch 10S	2.5 in.	2.64	16.9969	64.341	88.25	0.68	23.31	2.57
steel sch 40S	2.5 in.	2.47	14.8228	56.49	101.20	0.59	26.55	2.26
steel sch 80S	2.5 in.	2.32	13.2101	50.006	113.55	0.53	30.00	2.00
PVC sched 80	3 in.	2.86	20.0796	76.01	74.70	0.80	19.73	3.04
PVC sched 40	3 in.	3.04	22.6531	85.752	66.22	0.91	17.49	3.43
steel sch 5S	3 in.	3.33	27.2107	103	55.13	1.09	14.56	4.12
steel sch 10S	3 in.	3.26	26.0162	98.483	57.66	1.04	15.23	3.94
steel sch 40S	3 in.	3.07	23.042	87.224	65.10	0.92	17.20	3.49
steel sch 80S	3 in.	2.90	20.5876	77.933	72.86	0.82	19.25	3.12

Pipe type	pipe size	pipe id	gpm/fps	lpm/fps	K pls/gal	A gpm/Hz	K pls/l	A lpm/Hz
PVC sched 80	3.5 in.	3.33	27.0803	102.51	55.39	1.08	14.63	4.10
PVC sched 40	3.5 in.	3.52	30.3488	114.88	49.43	1.21	13.06	4.60
steel sch 5S	3.5 in.	3.83	35.9843	136.22	41.68	1.44	11.01	5.45
steel sch 10S	3.5 in.	3.76	34.6087	131.01	43.34	1.38	11.45	5.24
steel sch 40S	3.5 in.	3.55	30.816	116.65	48.68	1.23	12.86	4.67
steel sch 80S	3.5 in.	3.36	27.7026	104.87	54.15	1.11	14.30	4.19
PVC sched 80	4 in.	3.79	35.089	132.83	42.75	1.40	11.29	5.31
PVC sched 40	4 in.	4.00	39.1289	148.12	38.33	1.57	10.13	5.92
steel sch 5S	4 in.	4.33	45.9819	174.06	32.62	1.84	8.62	6.96
steel sch 10S	4 in.	4.26	44.4251	168.17	33.76	1.78	8.92	6.73
steel sch 40S	4 in.	4.03	39.6786	150.2	37.80	1.59	9.99	6.01
steel sch 80S	4 in.	3.83	35.8343	135.65	41.86	1.43	11.06	5.43
PVC sched 80	5 in.	4.77	55.6521	210.67	26.95	2.23	7.12	8.43
PVC sched 40	5 in.	5.02	61.592	233.15	24.35	2.46	6.43	9.33
steel sch 5S	5 in.	5.35	69.9366	264.74	21.45	2.80	5.67	10.59
steel sch 10S	5 in.	5.30	68.6343	259.81	21.85	2.75	5.77	10.39
steel sch 40S	5 in.	5.05	62.3557	236.04	24.06	2.49	6.35	9.44
steel sch 80S	5 in.	4.81	56.7076	214.66	26.45	2.27	6.99	8.59
PVC sched 80	6 in.	5.71	79.7865	302.03	18.80	3.19	4.97	12.08
PVC sched 40	6 in.	6.03	89.0406	337.06	16.85	3.56	4.45	13.48
steel sch 5S	6 in.	6.41	100.489	380.4	14.93	4.02	3.94	15.22
steel sch 10S	6 in.	6.36	98.9267	374.48	15.16	3.96	4.01	14.98
steel sch 40S	6 in.	6.07	90.0473	340.87	16.66	3.60	4.40	13.63
steel sch 80S	6 in.	5.76	81.2466	307.55	18.46	3.25	4.88	12.30
PVC sched 80	8 in.	7.57	140.096	530.33	10.71	5.60	2.83	21.21
PVC sched 40	8 in.	7.94	154.408	584.5	9.71	6.18	2.57	23.38
steel sch 5S	8 in.	8.41	173.018	654.95	8.67	6.92	2.29	26.20
steel sch 10S	8 in.	8.33	169.822	642.85	8.83	6.79	2.33	25.71
steel sch 40S	8 in.	7.98	155.928	590.26	9.62	6.24	2.54	23.61
steel sch 80S	8 in.	7.63	142.328	538.77	10.54	5.69	2.78	21.55
PVC sched 80	10 in.	9.49	220.605	835.09	6.80	8.82	1.80	33.40
PVC sched 40	10 in.	9.98	243.625	922.23	6.16	9.75	1.63	36.89
steel sch 5S	10 in.	10.48	268.966	1018.2	5.58	10.76	1.47	40.73
steel sch 10S	10 in.	10.42	265.794	1006.1	5.64	10.63	1.49	40.24
steel sch 40S	10 in.	10.02	245.779	930.38	6.10	9.83	1.61	37.22
steel sch 80S	10 in.	9.75	232.712	880.92	6.45	9.31	1.70	35.24
PVC sched 80	12 in.	11.29	312.252	1182	4.80	12.49	1.27	47.28
PVC sched 40	12 in.	11.89	346.019	1309.8	4.34	13.84	1.15	52.39
steel sch 5S	12 in.	12.44	378.713	1433.6	3.96	15.15	1.05	57.34
steel sch 10S	12 in.	12.39	375.796	1422.6	3.99	15.03	1.05	56.90
steel sch 40S	12 in.	12.00	352.51	1334.4	4.26	14.10	1.12	53.38
steel sch 80S	12 in.	11.75	337.975	1279.4	4.44	13.52	1.17	51.18

DIN Standard Plastic Pipe								
Pipe type	pipe size	pipe id	gpm/fps	lpm/fps	K	A	K	A
					pls/gal	gpm/Hz	pls/l	lpm/Hz
PP bar 10	63	51.4	10.02	37.943	149.63	0.40	39.53	1.52
PP bar 10	75	61.2	14.21	53.791	105.55	0.57	27.89	2.15
PP bar 10	90	73.6	20.55	77.797	72.98	0.82	19.28	3.11
PP bar 10	110	90	30.73	116.33	48.81	1.23	12.89	4.65
PP bar 10	125	102.2	39.63	150.01	37.85	1.59	10.00	6.00
PP bar 10	140	114.4	49.66	187.96	30.21	1.99	7.98	7.52
PP bar 10	160	130.8	64.92	245.71	23.11	2.60	6.10	9.83
PP bar 10	180	147.2	82.22	311.19	18.24	3.29	4.82	12.45
PP bar 10	200	163.6	101.56	384.39	14.77	4.06	3.90	15.38
PP bar 10	225	184	128.46	486.23	11.68	5.14	3.08	19.45
PP bar 10	250	204.4	158.53	600.03	9.46	6.34	2.50	24.00
PP bar 10	280	229	198.98	753.14	7.54	7.96	1.99	30.13
PP bar 10	315	257.6	251.79	953.01	5.96	10.07	1.57	38.12
PVDF bar 10	90	84.4	27.03	102.3	55.50	1.08	14.66	4.09
PVDF bar 10	110	103	40.25	152.36	37.26	1.61	9.84	6.09
PVDF bar 10	160	150	85.37	323.14	17.57	3.41	4.64	12.93
PVDF bar 10	200	187.6	133.54	505.44	11.23	5.34	2.97	20.22
PVDF bar 10	250	234.8	209.19	791.78	7.17	8.37	1.89	31.67
PVDF bar 16	63	57	12.33	46.661	121.67	0.49	32.15	1.87
PVDF bar 16	75	67.8	17.44	66.019	86.00	0.70	22.72	2.64
PVDF bar 16	90	81.4	25.14	95.161	59.66	1.01	15.76	3.81
PVDF bar 16	110	99.4	37.49	141.9	40.01	1.50	10.57	5.68
PVC bar 10	63	57	12.33	46.661	121.67	0.49	32.15	1.87
PVC bar 10	75	67.8	17.44	66.019	86.00	0.70	22.72	2.64
PVC bar 10	90	81.4	25.14	95.161	59.66	1.01	15.76	3.81
PVC bar 10	110	99.4	37.49	141.9	40.01	1.50	10.57	5.68
PVC bar 10	125	113	48.45	183.39	30.96	1.94	8.18	7.34
PVC bar 10	140	126.6	60.81	230.18	24.67	2.43	6.52	9.21
PVC bar 10	160	144.6	79.34	300.29	18.91	3.17	5.00	12.01
PVC bar 10	180	162.8	100.57	380.64	14.92	4.02	3.94	15.23
PVC bar 10	200	180.8	124.03	469.47	12.09	4.96	3.20	18.78
PVC bar 10	225	203.4	156.98	594.17	9.56	6.28	2.52	23.77
PVC bar 16	63	53.6	10.90	41.261	137.60	0.44	36.35	1.65
PVC bar 16	75	63.8	15.44	58.459	97.12	0.62	25.66	2.34
PVC bar 16	90	76.6	22.26	84.269	67.37	0.89	17.80	3.37
PVC bar 16	110	93.6	33.24	125.82	45.12	1.33	11.92	5.03
PVC bar 16	125	106.4	42.96	162.59	34.92	1.72	9.23	6.50
PVC bar 16	140	119.2	53.91	204.06	27.82	2.16	7.35	8.16
PVC bar 16	160	136.2	70.39	266.42	21.31	2.82	5.63	10.66

3.8 Custom K-factor calculation

K-factors can be calculated for any pipe using the pipe id and the ft/s engineering unit options. The procedure is based on the relationship between the frequency output and the flow velocity:

20 ft/s = 500 Hz. therefore 1 ft/s = 25 Hz.

1. Install the 2550 in pipe according to sec 2.2.

Example illustrates calculating a custom K-factor in GPM for pipe with 3.068 in. id.

2. Enter the pipe ID into the menu, and select Feet per Second (FPS) as the engineering unit.

Unit = ft/s

3. Establish a stable flow rate in the pipe. It is not important to know what the rate is, just that it be stable.

Display = 5.2 ft/s

4. Read the flow rate from display and multiply the display value (ft/s) by 25. (frequency can be verified by monitoring TS2 if desired.)

5.2 x 25 = 130 Hz

Record the result _____ ft/s = _____ Hz.

5.2 ft/s = 130 Hz.

5. Change the display to read in desired engineering units. **Do not change flow rate!**

*Unit = GPM
Display = 120 GPM*

Record the result _____ GPM = _____ Hz.

120 GPM = 130 Hz.

6. Divide the flow rate by the frequency result of step 3. Record the result:

Flow Rate/Hz = A = _____

A = 120 ÷ 130 = 0.92

7. K = 60 / A = _____

K = 60 ÷ 0.92 = 65.2

3.9 Spare parts list

		Code
1.	Access cover	3-2550.374
2.	Gasket, outer cover	1222-0439
3.	* Cable connector (standard) for .125 to .187 o.d. cable	1500-0101
	Cable connector (optional) for .187 to .250 od cable	1500-0102
4.	Fuse, 3/4 A slo-blo	6400-0020
5.	Installation tool	3-2550.355

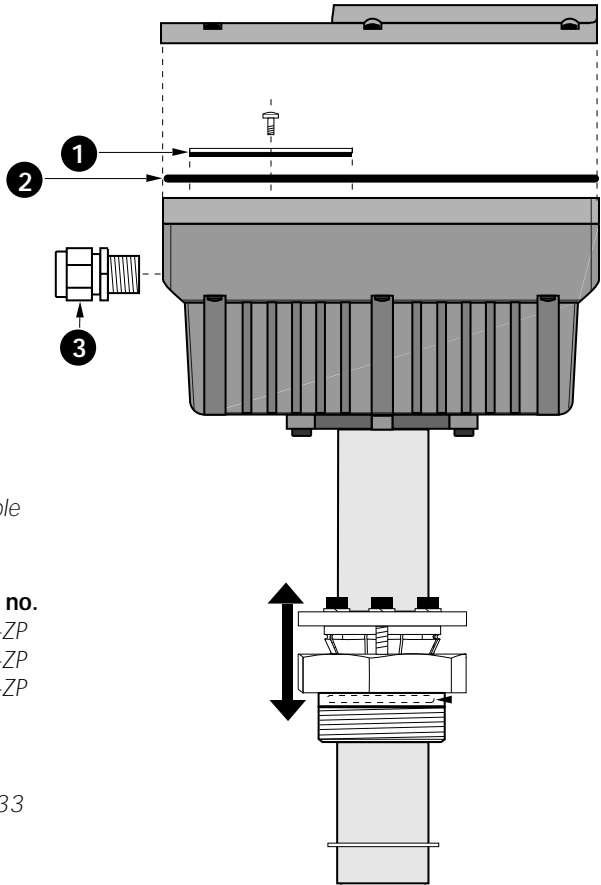

* Additional connector sizes available
from Hubbell Inc.:

Cable diameter	Hubbell part no.
0.250 to 0.312	#SHC-1010-ZP
0.312 to 0.375	#SHC-1011-ZP
0.375 to 0.437	#SHC-1012-ZP

Hubbell Incorporated
State Street and Bostwick Avenue
Bridgeport Connecticut 06605-0933
Phone: (203) 337-3100
Fax: (203) 368-6245

General Data

Flow velocity range:	0.1 to 6 m/s (0.3 to 20 ft/s)
Accuracy:	± 2% of reading or ±0.05 ft/s whichever is greater
Temperature coefficient:	≤0.015% per °C
Pipe size:	51 to 305 mm (2 to 12 in.), metal or plastic
Response time:	User Selectable: instantaneous/5/ 10/15/20/30/ 40/60/80 s.
Isolated current output:	4 to 20 mA or 0 to 20 mA, into 600 Ω max. load
Frequency output:	0 to 20 ft/s = 0 to 500 Hz isolated, open collector 50% duty cycle, (5 to 12 VDC)

Specifications

Materials

Enclosure:	Die cast aluminum, Nema 4/IP65
Sensor body:	316 stainless steel
Sensor tip:	PFA Teflon®
Electrodes:	316 stainless steel
Retaining ring:	316 stainless steel
Threaded nut:	316 stainless steel
Internal o-ring:	FPM Viton®

Electrical Data

Power Requirements: 24 VDC \pm 10%,
600 mA

Recommended power supply (or equivalent):

Model no. HB24-1.2A (24 V @ 1.2 A)

Power-One, Inc., Camarillo, Ca. U.S.A.

ph. 805/987-8741 toll free 800/678-9445

fax 805/388-0476

Magnetic field: Bipolar DC

Input signal impedance: $>10000 \text{ M}\Omega$

Ambient Conditions

Humidity: 100% RH,
non-condensing

Liquid temperature: 0 to 100 °C
(32 to 212 °F)

Ambient temperature: -20 to 80 °C
(-4 to 176 °F)

Minimum liquid conductivity: 5 $\mu\text{S}/\text{cm}$

Maximum operating pressure: 17 bar (250 psig)

Warranty

Limited Two-Year Warranty

Signet Scientific Company warrants its instruments to be free from defects in material and workmanship under normal use for a period of two years from the date of purchase by the initial owner, or three years from date of manufacture, whichever comes first, as described in the following paragraphs.

This warranty does not cover defects caused by abuse or electrical damage. Signet Scientific Company will not cover under warranty any instruments damaged during shipment to the factory less case or if improperly packed. Repair attempts by anyone other than authorized service personnel will void the warranty. Proof of date of purchase will be required before warranty repairs can begin. Transducers and cables will not be covered after installation.

Parts which prove to be defective in the first year will be repaired or replaced free of charge including labor, shipped F.O.B. our factory or a designated service center (addresses furnished upon request).

Only non-moving parts, such as electrical components, which prove defective during the second year are warranted. Meter movements will not be covered. All units qualifying for warranty service after one year are subject to a service charge for replacement of non-moving parts.

Items returned for warranty repair must be shipped prepaid and insured. Warranty claims are processed on the condition that prompt notification of a defect is given to Signet Scientific Company within the warranty period.

Signet Scientific Company shall have the sole right to determine whether in fact a warranty situation exists.

Signet Scientific Company is continually making design changes and improvements that adapt to the original circuit configuration. These will be incorporated as required in older units on a minimal charge basis while under warranty.

Consequential Damages

Signet Scientific Company shall not be liable for special consequential damages of any nature with respect to any merchandise or service sold, rendered or delivered.

This warranty gives you specific legal rights and you may also have other rights which vary from state to state.

NOTES:

+GF+ SIGNET

Signet Scientific Company, 3401 Aerojet Avenue, El Monte, CA 91731-2882/U.S.A.,
Phone (818) 571-2770, Fax (818) 573-2057

Representative Offices

U.S.A. George Fischer, Inc., 2882 Dow Avenue, Tustin, CA 92680-7285/U.S.A.,
Toll Free Phone (800) 854-4090, Fax (714) 731-6201

CH Georg Fischer Rohrleitungssysteme AG, CH-8201 Schaffhausen/Schweiz,
Tel. 053/81 11 11, Telex 89 70 70 64 gf ch, Fax 053/25 91 30

SIN George Fischer Pte Ltd., 15 Kaki Bukit Road 2, KB Warehouse Complex, Singapore 1441,
Tel: 65/747 0611, Fax: 65/747 0577

GEORGE FISCHER +GF+ Piping Systems

3-2550.090
E-9/96

© Signet Scientific Company 1992

Printed in U.S.A.