

Signet 2760 DryLoc® pH/ORP Preamplifiers & Connectors



Features

- In-line integral mount and submersible installation versions
- Automatic temperature compensation
- Auto configuration for pH or ORP operation
- Junction boxes for convenient wiring

Applications

- Water/Wastewater Treatment
- Neutralization Systems
- Scrubber Control
- Effluent Monitoring
- Surface Finishing
- Flocculent Coagulation
- Heavy Metal Removal and Recovery
- Toxics Destruction
- Sanitization Systems
- Pool & Spa Control
- Aquatic Animal Life Support Systems

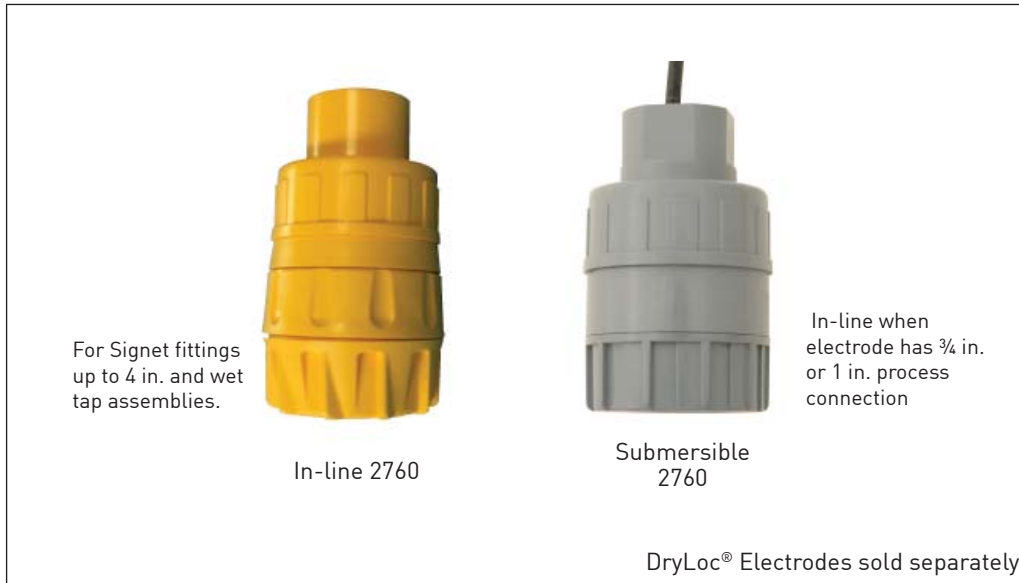

Description

The Signet 2760 pH/ORP Preamplifiers features the DryLoc® connector, providing a robust connection to Signet DryLoc® electrodes.

















The 2760 preamplifier allows any DryLoc® pH/ORP electrode to work with Signet ProcessPro® and ProPoint® pH/ORP instruments. It is also sold as a simple connector for use with other manufacturers' instruments that do not require a preamplified signal.

The DryLoc® electrode connector system quickly forms a robust assembly for submersible and in-line installations. NEMA 4X junction enclosures are to extend the preamplifier cable to long distances.

The 2760 submersible preamplifier can also be used as an In-line preamplifier when used with the 3/4 in. or 1 in. threaded sensors including the 2724, 2774 and 2764 series electrodes. The 2760 In-line preamplifier can be used with Signet fittings up to DN100 (4 in.) and wet-tap assemblies.

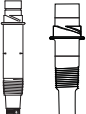

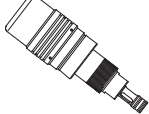
System Overview

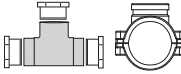
In-Line Installation		Submersible Installation	Wet-Tap Installation	
Panel Mount Signet Instrument (sold separately) 5700, 8750 	Pipe, Tank, Wall Mount Signet pH/ORP Transmitter (sold separately) 8750  Signet Universal Adapter Kit (3-8050) (sold separately) 	Panel, Pipe, Tank, Wall Mount Signet Instrument (sold separately) 5700, 8750  	Panel Mount Signet Instrument (sold separately) 5700, 8750 	Pipe, Tank, Wall Mount Signet pH/ORP Transmitter (sold separately) 8750  Signet Universal Adapter Kit (3-8050) (sold separately) 
Signet 2760 Preamplifier 	Signet 2760 Preamplifier 	Pipe extension or conduit with 3/4 in. NPT or ISO 7/1-R 3/4 threads (customer supplied) 	Signet 2760 Preamplifier with Signet Wet-Tap Electrode 2756, 2757 (each sold separately) 	
DryLoc® pH/ORP Electrodes 2724-2726, 2764-2767, 2774-2777 (sold separately) 		Signet 2760 and Preamplifier 	Signet 3719 Wet-Tap (sold separately) 	
2724-2726 DryLoc® Electrodes: Use GF Fittings* or 3/4 in. NPT fittings (customer supplied) 2764-2767 and 2774-2777 DryLoc® Electrodes: Use 3/4 in. or 1 in. NPT fittings (customer supplied)		DryLoc® pH/ORP Electrodes 2724-2726, 2764-2767, 2774-2777 (sold separately) 	GF PP Clamp-On Saddles for 3719 Wet-Tap or GF Tees and Fittings (sold separately) see model 3719 for more info 	

Dimensions

3-2760-1, -2, -3, -4

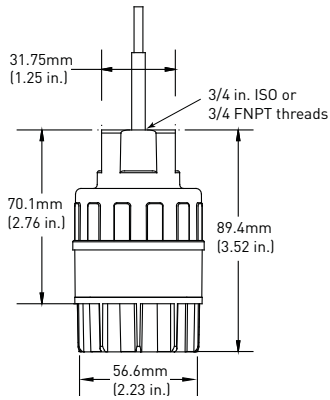

3-2760-11, -21, -31, -41

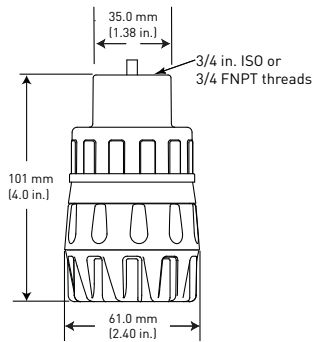

Specifications

General

Compatible Electrodes:

Signet DryLoc® pH and ORP Electrodes
Models 2724-2726, 2756-2757 Wet-Tap
2764-2767, 2774-2777

All pH sensors used with the 2760 must have a 3K Temperature sensor

Operating Range:

- pH: 0 to 14 pH
- ORP: $\pm 2,000$ mV

Response Time*:

- pH: < 6 sec. for 95% of change
- ORP: application dependent

Materials:

- In-line: Valox® (PBT)
- Submersible: CPVC

Electrical

Cable:

- 4.6 m/15 ft, supplied, 120 m/400 ft max
- 6 cond., foil shield with drain wire, 24 AWG

Environmental

Enclosure:

- Submersible: NEMA 6P/IP68 with electrode and watertight conduit and/or extension pipe connected
- In-line: NEMA 4 with electrode and watertight conduit and/or extension pipe connected

Max. Temperature/Pressure Rating

Operating Temperature:

- Temperature (submersible): 0 °C to 85 °C (32 °F to 185 °F)
- Temperature (in-line): 0 °C to 110 °C (32 °F to 230 °F)

Storage Temperature:

-20 °C to 85 °C (-4 °F to 185 °F)

Relative Humidity:









0 to 95%, non-condensing (without electrode connected)

Shipping Weight 0.64 kg 1.41 lb

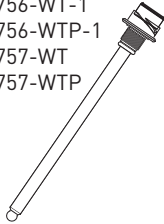
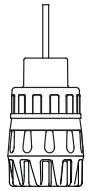
Standards and Approvals

- CE
- Manufactured under ISO 9001 for Quality and ISO 14001 for Environmental Management

2760 Product Selection Guide

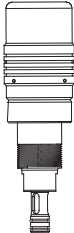
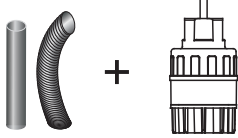
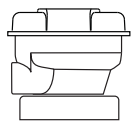
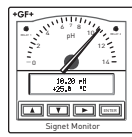
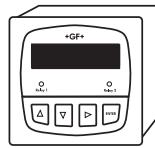
<p>1. Choose the Electrode</p>	<p>2724-2726 3-2724-10, -11 3-2725-60, -61 3-2726-10, -11 3-2726-HF-10, -11 3-2726-LC-10, -11</p> 	<p>2764-2767 Differential</p> <p>3-2764-1 3-2765-1 3-2766-1 3-2767-1</p> 	<p>2774-2777</p> <p>3-2774 3-2775 3-2776 3-2777</p> 	<p>2756 and 2757 Wet-Tap</p> <p>3-2756-WT-1 3-2756-WTP-1 3-2757-WT 3-2757-WTP</p> 		
<p>2. Determine the mounting style:</p> <p>In-line</p> <p>-In-line fitting</p> <p>Submersible</p>	 <p>2760-11 or -21</p>	 <p>2760-1 or -2</p>	 <p>2760-11 or -21</p>	 <p>2760-1 or -2</p>	 <p>2760-11 or -21</p>	 <p>2760-11 or -21</p>  <p>3719 Wet-Tap Assembly</p> <p>(Submersible not applicable with Wet-Tap assembly)</p>
<p>Signet fitting</p>	<p>3/4" reducing tee</p>	<p>1" threaded tee</p>	<p>3/4" reducing tee</p>			
<p>2760-1 or -2 and cable conduit (customer supplied) connected to 3/4" sensor electronics</p>						
<p>3. Junction Boxes</p>	<p>3-8050-1: Use when extending the submersible cable over long distance. 3-8050-2: Use with the submersible 2760-1 or -2. For simple calibration with the EasyCal function.</p>					
<p>4. Choose the Signet instrument</p>	 <p>5700</p> <p style="text-align: center;">OR</p>  <p>8750</p>					

Ordering Information

Model 2760

Ordering Information

- 1) Conduit and mounting brackets for submersion installation must always be used (customer supplied).
- 4) The 3-2759 System Tester must be ordered with the adapter cable 3-2759.391 for exclusive use with the 2760.
- 5) All sensor preamplifiers and connectors require a DryLoc® electrode for full system installation.
- 6) Use Models 2724-2726, 2756-WT, 2757-WT, 2764-2767 and 2774-2777 pH and ORP electrodes with the 2760.

Preamplifier and Connector		
3-2760	pH/ORP Preamplifier (for use with the 8750 or 5700 instrument) or Connector (for use with other manufacturer's instruments) with 4.6 m (15 ft cable)	
↓	Preamplifier	
	-1	Preamplifier, with ¾ in. NPT threads and 4.6 m (15 ft) cable
	-2	Preamplifier, with ¾ in. ISO threads and 4.6 m (15 ft) cable
	Connectors (for use with other manufacturer's instruments)	
	-3	Connector with 4.6 m (15 ft) cable and ¾ in. NPT threads
	-4	Connector with 4.6 m (15 ft) cable and ISO 7/1R 3/4 threads
	Mounting Configurations	
	-	Submersible mounting (gray body)
	1	In-line mounting (yellow body); use for wet-tap sensors
	3-2760	-2 Example Part Number

Mfr. Part No.	Code
3-2760-1	159 000 939
3-2760-2	159 000 940
3-2760-3	159 000 941
3-2760-4	159 000 942
3-2760-11	159 001 367
3-2760-21	159 001 368
3-2760-31	159 001 369
3-2760-41	159 001 370

Accessories and Replacement Parts

Mfr. Part No.	Code	Description
Calibration		
3-2700.395	159 001 605	Calibration kit: includes 3 PP cups, cup stand, 1 pint pH 4.01, 1 pint pH 7.00)
3822-7115	159 001 606	20 gm bottle Quinhydrone for ORP calibration (must use pH 4.01 and/or pH 7.00 buffer solutions)
3-2759	159 000 762	pH/ORP system tester (adapter cable sold separately)
3-2759.391	159 000 764	2759 adapter cable for use with 2750 and 2760
3-0700.390	198 864 403	DryLoc® sensor electronics
3822-7004	159 001 581	pH buffer kit (1 each 4, 7, 10 pH buffer in powder form, makes 50 ml of each)
3822-7007	159 001 582	pH 4 buffer solution, 1 pint (473 ml) bottle
3822-7010	159 001 583	pH 7 buffer solution, 1 pint (473 ml) bottle
		pH 10 buffer solution, 1 pint (473 ml) bottle
Mounting		
3-8050-1	159 000 753	Universal mount junction box
3-8050-2	159 000 754	Universal mount junction box w/EasyCal
3-9000.392-1	159 000 839	Liquid tight connector kit, NPT (1 connector)
3-9000.392-2	159 000 841	Liquid tight connector kit, PG 13.5 (1 connector)
Other		
5523-0624	159 000 636	Cable, 6-cond. plus shield, 24 AWG, black/red/white (for use with 2760, orders must specify length per foot)

Application Tips

- The EasyCal feature automatically recognizes standard 4.0, 7.0, and 10.0 pH buffer or ORP Quinhydrone solutions of 87 and 264 mV and simplifies calibration
- Frequency of calibration of electrodes is dependent upon the application.

3-2760.099 Rev A (01/10)

© Georg Fischer Signet LLC

3401 Aerojet Avenue, El Monte, CA 91731-2882 U.S.A. • Tel. (626) 571-2770 • Fax (626) 573-2057 • www.gfsignet.com • e-mail: signet.ps@georgfischer.com
 Specifications subject to change without notice. All rights reserved. All corporate names and trademarks stated herein are the property of their respective companies.