

Signet 2764-2767 Differential DryLoc® pH/ORP Electrodes



Description

The Signet 2764-2767 Differential pH & ORP electrodes are built with the DryLoc® connector, a Ryton® body, and PTFE reference junction to handle the most extreme and harshest of chemical applications.

These differential electrodes use a field-proven 3-electrode differential technique: the pH and reference electrodes are measured against a ground electrode, insuring a steady and stable signal. A key feature is the reference electrode, which is housed in a glass half-cell embedded in the reference chamber and is protected from compounds that may contain sulfides (S₂) and metals. To ensure long service life, the reference features a refillable electrolyte chamber and a replaceable equitransferant salt bridge, both easily serviced in the field. The patented porous PTFE reference junction resists fouling, clogging and chemical attack.

Other elements of the design are the solution ground, the pH/ORP electrodes, and the temperature element. The solution ground eliminates noisy measurements by draining electrical current away from the reference electrode. The pH/ORP electrodes are designed with a flat or bulb measurement surface, and a temperature device that is positioned at the tip of the measurement surface, making the temperature response of T_{95%} less than 1 minute. Various temperature devices offered include 3 KΩ, 300 Ω, or PT1000 RTD.

The electrodes are used with the Signet 2750 Sensor Electronics, which provide a blind 4 to 20 mA output or use the digital (S³L) output to connect the Signet 8900 Multi-Parameter Controller. The electrodes can also be used with the Model 2760 preamplifier to connect to the Signet 5700 or 8750.

Features

- Differential design for stable measurements in the most aggressive applications
- Long service life even in severe or difficult chemical applications
- Water-tight DryLoc® connector with foul-proof gold contacts
- Porous PTFE reference junction
- Rebuildable reference electrode
- Solution ground
- Temperature sensor (pH)
- Easy sensor replacement using DryLoc® electrode connector
- Quick temperature response
- Compatible with all Signet instruments and other suppliers' pH/ORP instruments

System Overview

In-Line Installation				Submersible Installation	
Panel Mount Signet Instrument (sold separately) 5700 8750 8900 	4 to 20 mA Input Chart Recorder OR Programmable Logic Controller 	Pipe, Tank or Wall Mount Signet Instrument (sold separately) 8750 Signet Universal Adapter Kit (3-8050) (sold separately) Signet 2760 (sold separately) 	Other Instruments Customer supplied Signet 2760 (sold separately) 	Panel, Pipe, Tank, Wall Mount Signet or Other Instrument 5700 8750 8900 Pipe extension or conduit with 3/4 in. FNPT threads (customer supplied) 	
Signet 2750 or Signet 2760 (sold separately) 	Signet 2750 (sold separately) 	Signet 2760 (sold separately) 	Signet 2760 (sold separately) 	Signet 2750 or Signet 2760 (sold separately) 	
Signet 2764-2767 Differential pH/ORP Electrodes 				Signet 2764-2767 Differential pH/ORP Electrodes 	
Fittings - Customer supplied					

Applications

- Water and Waste Water Treatment
- Coagulation and Flocculation
- Plant Effluent
- Plating Baths
- Scrubbers
- Textile Dye Process
- Harsh Chemical Applications
- Heavy metal Removal and Recovery
- Toxics Destruction
- Surface Finishing

See Technical Reference section for assistance in choosing the correct sensor.

Dimensions

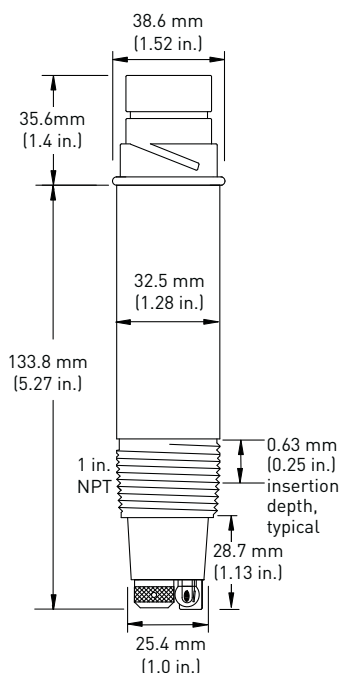

Flat and Bulb versions have the same dimensions

Specifications

General

Compatibility: Signet 2750 and 2760

Operating Range:

- 2764/2766: 0 to 14 pH
- 2765/2767: +/-1500 mV (ORP)

Process Connection: 1 in., for use in reducing tees up to 4 in.

Wetted Materials

Body: Ryton®

Reference Junctions: PTFE

Sensing Surface:

- Glass membrane: (pH)
- Platinum: (ORP)

O-rings: FPM

Solution Ground: carbon graphite

Max. Temperature/Pressure Rating

Operating Temperature:

0 °C to 95 °C (32 °F to 203 °F)

Max. Operating Pressure:

6.89 bar (100 psi) @ 95 °C (203 °F)

Storage Temperature: > 0 °C (32 °F)

Recommended Storage Temp.

The best storage temperature for the 276X pH and ORP electrodes is 0 °C to 50 °C (32 °F to 122 °F)

- The electrode glass will shatter if shipped or stored at temperature below 0 °C (32 °F)
- The performance life of the electrode will shorten if stored at temperatures above 50 °C (122 °F)

Mounting

- In-line/vertical mounting: Use sensor 1 inch threads. Sensor must be mounted at least 15 degrees above the horizontal axis.
- Submersible mounting: Use threads on Model 2750 or 2760; requires ¾ inch NPT or ISO 7/1-R ¾ inch male threaded extension.

Reference:

Electrolyte:

3.5 M KCl, solidified acrylamide gel

Element: Ag/AgCl

Temperature Sensor:

- pH: 3 KΩ, PT1000 RTD, or 300 Ω
- ORP: 10K ID Resistor, PT1000 RTD, or 300 Ω

Primary Functions:

- 2764 and 2765: Flat surface resists fouling
- 2766 and 2767: Bulb surface for general use

Shipping Weight 0.25 kg 0.55 lb

Standards & Approvals

- Manufactured under ISO 9001 for Quality

A Differential electrode solves many common problems typically experienced by standard pH/ORP electrodes at troublesome measuring points. See the table below to find the common problem, cause and effect, and the Differential pH/ORP electrode solution.

If the standard (Signet Models 272X or 277X) pH/ORP electrode experiences the following:	The cause and effect of the problem may be:	Use a Differential Electrode to solves the problem because:
*Reading slowly drifts over time *Sensor responds slowly	*Chemical attack from Hg ⁺⁺ , Cu ⁺ , Pb ⁺⁺ , ClO ₄ ⁻ or other compounds which dilute the KCl reference electrolyte concentration.	*Salt bridge will slow or stop attack. If attacking ions penetrate the salt bridge and affect the KCl, simply refill KCl solution
	*Reference junction gets clogged from oils, grease, and dirt from the process.	*Readings do not drift due to stable Differential reference design, however may require cleaning or replacement of the salt bridge if electrode gets too dirty.
*Reading slowly drifts over time *Sensor reading becomes erratic	*Chemical attack of the Ag ⁺ reference billet from Br ⁻ , I ⁻ , CN ⁻ , and S ₂ ⁻ compounds.	*Will not affect electrode due to Ag ⁺ element protected in glass encased reference electrode.
	*Clogged reference and slowed reading from silver compounds forming on the inside of the reference electrode from Ag ⁺ of reference element reacting and precipitating AgS, AgBr, AgI, AgCN, or other silver compounds.	*Will not affect electrode due to Ag ⁺ element protected in glass encased reference electrode
*Reading suddenly jumps to a new value *Reading unexpectedly changes	*Stray electrical currents in the process liquid; Ag ⁺ reference element picks up current and shifts reference reading, resulting in shifted pH reading. The Ag ⁺ element will eventually become totally stripped. Process must be properly grounded or place metal rod close to electrode.	*Will not affect electrode due to Ag ⁺ element protected in glass encasement; also, electrode has a built in solution ground, so if there is a stray current, it will not be seen by the electrode

Ion	Ion name	Ion	Ion name	Compound	Compound name
Br ⁻	Bromide	Hg ⁺⁺	Mercury	KCl	Potassium Chloride
Cu ⁺	Copper iron	ClO ₄ ⁻	Perchlorate	AgS	Silver sulfide
CN ⁻	Cyanide	Ag ⁺	Silver	AgBr	Silver bromide
I ⁻	Iodide	S ₂ ⁻	Sulfide	AgI	Silver iodide
Pb ⁺⁺	Lead			AgCN	Silver cyanide

Electrode Key Features and Benefits:

- Glass encased reference electrode protects the Ag/AgCl (silver/silver chloride) element from reacting with certain chemical compounds that typically leach into the reference chambers. Keeps the pH/ORP reading stable.
- Large volume reference electrolyte chamber resists dilution over time for a long service life. Chamber is refillable. Holds approximately 30 ml of electrolyte
- Salt Bridge serves as a double reference junction and is the first line of defense to keep out process chemicals from the reference electrolyte chamber. It is built with a porous PTFE reference junction which is highly compatible to chemicals, resists fouling and build-up of dirt.
- Ryton® body for chemical compatibility to most harsh chemicals. Also able to withstand high temperatures.
- DryLoc® connector with corrosion resistant gold pins for quick and easy sensor removal.
- Capillary TC (temperature sensor) embedded in tip of pH/ORP electrode for quicker temperature response than most other electrodes on the market.

Electrode Cut-Away View

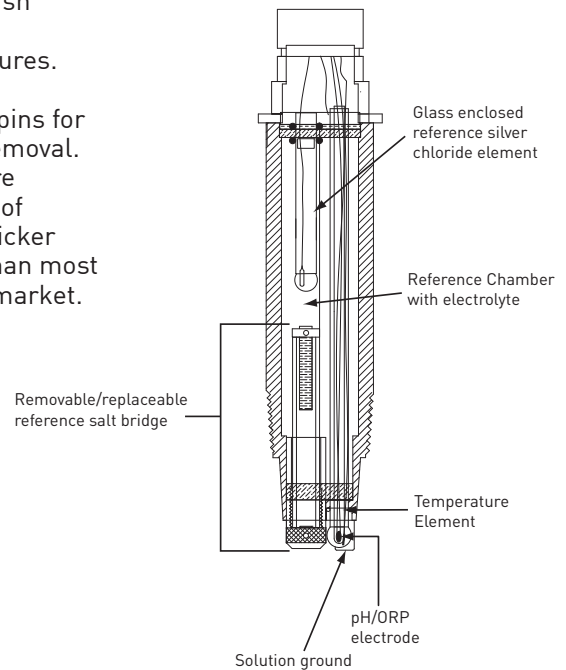

Application Tips

- Use the flat glass electrodes when a self-cleaning feature is desired; especially useful in applications with abrasive chemicals.
- Use bulb protected electrodes for general purpose applications
- ORP electrodes are generally used for chemical reaction monitoring, not control.
- Ensure that sensor materials are chemically compatible with the process liquid.
- Keep electrode tip wet, avoid air pockets and sediment.

Model 2764-2767

Ordering Notes

- 1) pH and ORP electrodes require connection to model 2750 or 2760.
- 2) Conduit and mounting brackets for submersible installations must always be used (customer supplied)
- 3) Adapters from 1 - 1½ in. are available.
- 4) Use sensor threads for in-line mounting; Model 2750 or 2760 threads for submersible mounting.
- 5) Reference electrode can be rebuilt with replacement electrolyte and salt bridge.

Ordering Information

Electrode Part Number- Choose Either a pH or ORP Electrode	
pH Electrode	
3-2764	Flat pH surface differential electrode
3-2766	Bulb pH differential electrode with bulb protection
↓	Temperature Element - Choose One
	-1 3K Ω for pH for connection to 8750 or 5700 instruments when used with the 2760 preamplifier**
	-2 PT1000 RTD for pH for use with the 8900 instrument when used with the 2750 sensor electronics*
	-3 300 Ω for connection to other instruments when used with the 2760 preamplifier or connector**
ORP Electrode	
3-2765	Flat ORP surface differential electrode
3-2767	Bulb ORP differential electrode with bulb protection
↓	Temperature Element - Choose One
	-1 10 KΩ ID resistor for connection to 8750 or 5700 when used with the 2760 preamplifier or connection to the 8900 with the 2750 sensor electronics
	-2 PT1000 RTD for connection to other instruments using the 2760 preamplifier or connector
	-3 300 Ω for connection to other instruments using the 2760 preamplifier or connector**
3-2765	-1 Example Part Number

*The 2750 sensor electronics has a digital (S³L) output which is used with the 8900 Controller. It also has a 4 to 20 mA output for connections to PLC's, data recorders, etc.

**The 2760 preamplifier is used for connection directly to Signet 5700 Monitor or 8750 transmitter.

Mfr. Part No.	Code	Mfr. Part No.	Code
3-2764-1	159 000 943	3-2766-1	159 000 949
3-2764-2	159 000 944	3-2766-2	159 000 950
3-2764-3	159 000 945	3-2766-3	159 000 951
3-2765-1	159 000 946	3-2767-1	159 000 952
3-2765-2	159 000 947	3-2767-2	159 000 953
3-2765-3	159 000 948	3-2767-3	159 000 954

Accessories and Replacement Parts

Mfr. Part No.	Code	Description
3-2700.395	159 001 605	Calibration kit: includes 3 PP cups, cup stand, 1 pint pH 4.01, 1 pint pH 7.00
3822-7115	159 001 606	20 gm bottle Quinhydrone for ORP calibration (must use pH 4.01 and/or pH 7.00 buffer solutions)
3864-0001	159 001 007	Replacement salt bridge
3864-0002	159 001 008	Replacement reference electrolyte solution, 500 mls
2120-0015	159 001 009	CPVC adapter: 1.5 in. MNPT to 1 in. FNPT
2122-0015	159 001 010	PVDF adapter: 1.5 in. MNPT to 1 in. FNPT
3-0700.390	198 864 403	pH buffer kit (1 each 4, 7, 10 pH buffer in powder form, makes 50 ml of each)
3822-7004	159 001 581	pH 4 buffer solution, 1 pint (473 ml) bottle
3822-7007	159 001 582	pH 7 buffer solution, 1 pint (473 ml) bottle
3822-7010	159 001 583	pH 10 buffer solution, 1 pint (473 ml) bottle
3-2759	159 000 762	pH/ORP system tester
3-2759.391	159 000 764	Adapter cable for use with 2750/2760

3-2764.099 Rev A (01/10)

© Georg Fischer Signet LLC

3401 Aerojet Avenue, El Monte, CA 91731-2882 U.S.A. • Tel. (626) 571-2770 • Fax (626) 573-2057 • www.gfsignet.com • e-mail: signet.ps@georgfischer.com
Specifications subject to change without notice. All rights reserved. All corporate names and trademarks stated herein are the property of their respective companies.