

P51590-1
15/97



SAFETY INSTRUCTIONS

1. Do not remove from pressurized lines.
2. Do not exceed maximum temperature/pressure specifications.
3. Do not install/service without following installation instructions (see sensor manual).
4. Wear safety goggles and face shield during installation/service.
5. Do not alter product construction.
6. Failure to follow safety instructions could result in severe personal injury!

1. Location of Fitting

Recommended sensor upstream/downstream mounting requirements

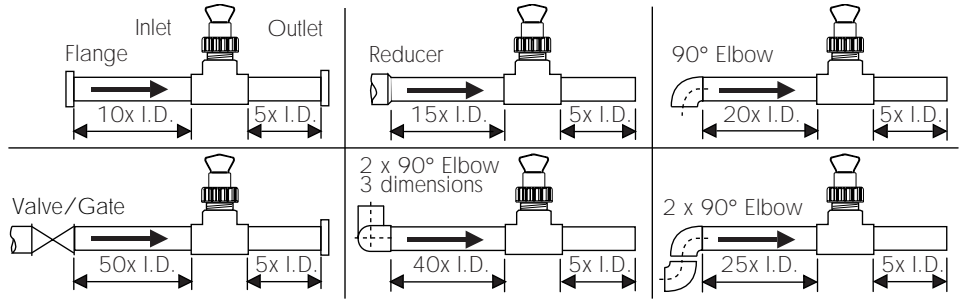

2. Sensor Mounting Position

- Horizontal pipe runs: Mount sensor in the upright (0°) position for best overall performance. Mount at a maximum of 45° when air bubbles are present. Do not mount on the bottom of the pipe when sediments are present.

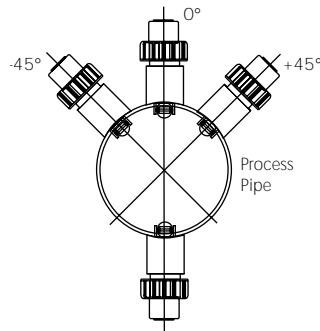

- Vertical pipe runs: Sensor must be mounted in lines with UPWARD flow only.



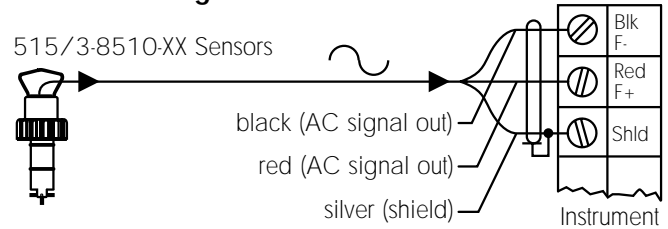

3. Sensor Wiring



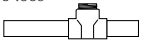

Technical Notes

- Use 2-conductor shielded cable for cable extensions up to 60 m (200 ft).
- Cable shield must be maintained through cable splice.
- Refer to your instrument manual for specific wiring details.

4. +GF+ SIGNET Fittings

Type	Description
Plastic tees 	<ul style="list-style-type: none"> • 0.5 to 4 in. versions • PVC or CPVC • Mounts via glue-on fittings
PVC glue-on saddles (O-ring not required) 	<ul style="list-style-type: none"> • 2 to 4 in., cut 1-7/16 in. hole in pipe • 6 to 8 in., cut 2-1/4 in. hole in pipe • Align wedge arrows with saddle arrows during assembly. • Pipes over 8 in., use iron saddle
Iron strap-on saddles 	<ul style="list-style-type: none"> • 2 to 4 in., cut 1-7/16 in. hole in pipe • Over 4 in., cut 2-1/4 in. hole in pipe • Special order over 12 in.
Carbon steel weld-on weldolets 	<ul style="list-style-type: none"> • 2 to 4 in., cut 1-7/16 in. hole in pipe • Over 4 in., cut 2-1/4 in. hole in pipe • Remove insert before welding • Installed by certified welder only • Special order over 12 in.
Carbon steel threaded tees 	<ul style="list-style-type: none"> • 0.5 to 2 in. versions • Mounts on threaded pipe ends

Type	Description
	Metric plastic saddle <ul style="list-style-type: none"> • For pipes DN 65 to 200 mm • Requires a 30 mm diam. hole in the pipe • Wedge and saddle arrow must match
	Metric wafer fitting <ul style="list-style-type: none"> • For pipes DN 65 to 200 mm • Follow the recommended installation guidelines
	Metric union fitting <ul style="list-style-type: none"> • For pipes from DN 15 to 50 mm • PP or PVDF • Follow the recommended installation guidelines

5. H-Dimensions

The plastic sensor insert in the Weldolet fitting MUST be removed during the welding process. When reinstalled, it is important that the insert be threaded to the proper height ("H" dimension).

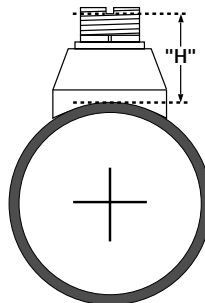

Weldolet part number	"H" dimension inches	"H" dimension mm	Weldolet part number	"H" dimension inches	"H" dimension mm
CS4W020	2.38	60.45	CS4W240	4.16	105.66
CS4W025	2.33	59.18	CS4W360	4.10	104.14
CS4W030	2.32	58.92			
CS4W040	2.30	58.42	CR4W020	2.38	60.45
CS4W050	3.09	78.48	CR4W025	2.33	59.18
CS4W060	2.96	75.18	CR4W030	2.32	58.92
CS4W080	2.73	69.34	CR4W040	2.30	58.42
CS4W100	5.48	139.19	CR4W050	3.09	78.48
CS4W120	5.25	133.35	CR4W060	2.96	75.18
CS4W140	5.10	129.54	CS4W080	2.73	69.34
CS4W160	4.85	123.19	CR4W100	5.48	139.19
CS4W180	4.60	116.84	CR4W120	5.25	133.35
CS4W200	4.38	111.25			

6. Standard Sensor Installation

1. Lubricate the sensor O-rings with a silicone lubricant (e.g. GE silicone compound #G632 or equivalent). Do not use any petroleum based lubricant that will attack the O-rings.
2. Using an alternating/twisting motion, lower the sensor into the fitting, making sure the installation arrows on the black cap are pointing in the direction of flow, **see Figure A.**
3. Engage one thread of the sensor cap then turn the sensor until the alignment tab is seated in the fitting notch. **Hand tighten the sensor cap. DO NOT** use any tools on the sensor cap or the cap threads and/or fitting flange threads will be damaged, **see Figure B.**

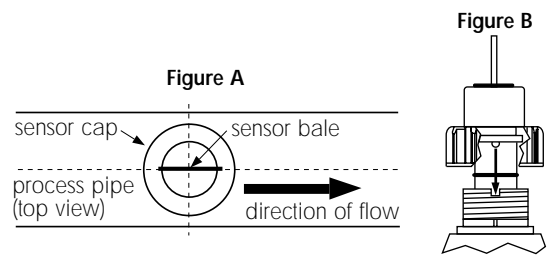

7. Wet-Tap Installation

The +GF+ SIGNET 319 Wet-Tap Assembly attaches directly onto any +GF+ Signet fitting to enable sensor removal without system shutdown. It consists of a flange and support plate which thread onto the pipe fitting insert, and a PVC ball valve through which an extended length 515 sensor is inserted into the pipe.

Procedure

1. Remove six hex nuts and bolts from the Wet-Tap flange. Separate the support plate from the main assembly. Be sure that the Viton O-ring is properly seated in the support plate groove.
2. Apply sealant to the pipe fitting insert threads to prevent leaks.
3. Screw support plate onto pipe fitting insert. It must be threaded completely down until the notches at the top of the pipe fitting insert are exposed.
4. Mount the main Wet-Tap Assembly on the support plate. Make certain the alignment keys on the flange mate with the notches on the pipe fitting insert.
5. Replace the six hex nuts and bolts to secure the Wet-Tap Assembly in place. Adjust the support plate position as necessary to align screws.
6. Check the pressure relief plug on Wet-Tap Assembly. It must closed be finger tight to prevent leaks.
7. Close ball valve by turning the orange handle to the fully closed position (parallel with pipe).

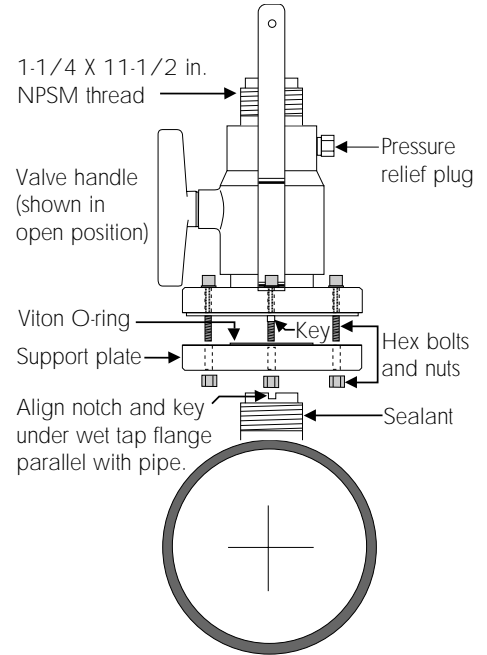

8. Wet-Tap Sensor Installation



The 319 Wet-Tap Assembly allows installation into pressurized pipes without system shutdown. **+GF+ Signet recommends reducing flow system pressure to 25 psi or less during sensor installation in a pressurized pipe.**

Non-Pressurized Installation

Open the orange ball valve handle to the full open position. Follow the steps 1-3 outlined in section 6. Attach the cable clamps and safety cables to the cable brackets. Verify the relief valve is closed before system operation, **see Figure C.**

Pressurized Installation

1. Lubricate the sensor O-rings with a silicone lubricant (e.g. GE silicone compound #G632 or equivalent). Do not use any petroleum based lubricant that will attack the O-rings.
2. Being careful not to bump the sensor rotor against the closed ball valve orifice, gently insert the extended 515 sensor into the 319 Assembly until the first two O-rings seat inside the bore, **see Figure D.**
3. Attach the cable clamps on each of the sensor's safety cables to the 319 assembly cable brackets (Hand tighten only), **see Figure D.**
4. Pull the flow sensor upward to remove slack in the safety cables, **see Figure E**
5. Reduce system pressure to 25 psi or less.
6. **Wearing safety face protection,** slowly open the ball valve to the full open position (perpendicular to pipe).
7. Using an alternating/twisting motion, push the extended sensor into the 319 assembly, making sure the sensor's installation decal is pointing in the direction of flow and the alignment tab seats into the fitting notch, **see Figure F.** Align the tab under the red sensor cap in the notches on the fitting insert. Hand tighten the red sensor cap, **see Figure G.** DO NOT use any tools on the red sensor cap or the cap threads and/or fitting flange threads will be damaged.

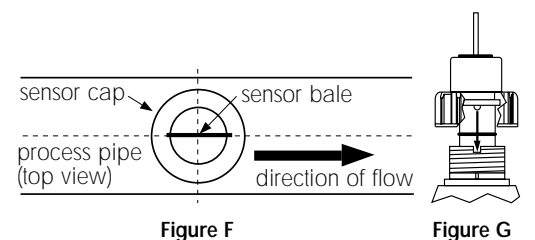
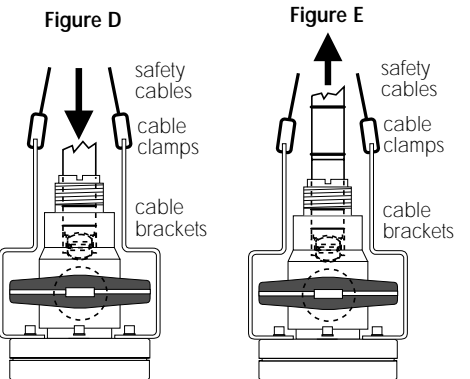
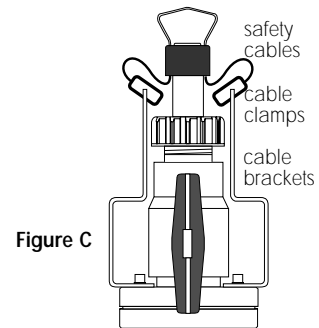

CAUTION: Maximum 319 Wet-Tap operating pressure: 7 bar (100 psi) @ 20 °C (68 °F)
Maximum 515 sensor installation/removal pressure: 1.7 bar (25 psi) @ 22 °C (72 °F)

9. K-Factors

The **K-Factor** is the number of pulses the sensor will generate for each engineering unit of fluid which passes. They are listed in U.S. gallons and in liters. For example, in a 1 inch PVC pipe, the paddlewheel generates 176.670 pulses per gallon of fluid passing the rotor. K-factors are listed for pipes up to 12 inch. For pipes over 12 inch, consult your +GF+ Signet distributor.

PIPE SIZE	+GF+ SIGNET FITTING TYPE	----K-FACTOR----		PIPE SIZE	+GF+ SIGNET FITTING TYPE	----K-FACTOR----		PIPE SIZE	+GF+ SIGNET FITTING TYPE	----K-FACTOR----				
		U.S. GAL	LITERS			U.S. GAL	LITERS			U.S. GAL	LITERS			
SCH 80 PVC TEES FOR SCH 80 PVC PIPE				GALVANIZED IRON TEES ON SCH 40 PIPE				COPPER/BRONZE BRAZOLETS ON SCH 40 PIPE						
1/2 IN.	PV8T005	480.190	126.867	1 IN.	IR4T010	104.538	27.619	2 1/2 IN.	BR4B025	18.800	4.967			
3/4 IN.	PV8T007	257.720	68.090	1 1/4 IN.	IR4T012	62.979	16.639	3 IN.	BR4B030	12.170	3.215			
1 IN.	PV8T010	174.670	46.148	1 1/2 IN.	IR4T015	46.688	12.335	4 IN.	BR4B040	6.960	1.839			
1 1/4 IN.	PV8T012	83.390	22.032	2 IN.	IR4T020	29.459	7.783	5 IN.	BR4B050	5.260	1.390			
1 1/2 IN.	PV8T015	58.580	15.477	BRONZE TEES ON SCH 40 PIPE				6 IN.	BR4B060	3.690	0.975			
2 IN.	PV8T020	32.480	8.581	1 IN.	BR4T010	104.538	27.619	8 IN.	BR4B080	2.130	0.563			
2 1/2 IN.	PV8T025	21.833	5.768	1 1/4 IN.	BR4T012	62.979	16.639	10 IN.	BR4B100	1.350	0.357			
3 IN.	PV8T030	13.541	3.578	1 1/2 IN.	BR4T015	46.688	12.335	12 IN.	BR4B120	0.960	0.254			
4 IN.	PV8T040	7.626	2.015	2 IN.	BR4T020	29.459	7.783	SCH 80 IRON SADDLES ON SCH 80 PIPE						
SCH 80 CPVC TEES FOR SCH 80 CPVC PIPE				COPPER TEE FITTINGS ON COPPER PIPE PIPE				2 IN.				IR8S020	32.360	8.550
1/2 IN.	CPV8T005	480.190	126.867	1/2 IN. SK K	CUKT005	443.206	117.095	2 1/2 IN.	IR8S025	22.220	5.871			
3/4 IN.	CPV8T007	257.720	68.090	1/2 IN. SK L		414.413	109.488	3 IN.	IR8S030	13.420	3.546			
1 IN.	CPV8T010	174.670	46.148	3/4 IN. SK K	CUKT007	212.156	56.052	4 IN.	IR8S040	7.660	2.024			
1 1/4 IN.	CPV8T012	83.390	22.032	3/4 IN. SK L		191.086	50.485	5 IN.	IR8S050	5.860	1.548			
1 1/2 IN.	CPV8T015	58.580	15.477	1 IN. SK K	CUKT010	127.176	33.600	6 IN.	IR8S060	4.090	1.081			
SCH 80 PVC SADDLES FOR SCH 80 PVC PIPE				1 IN. SK L		119.840	31.662	8 IN.	IR8S080	2.330	0.616			
2 IN.	PV8S020	32.480	8.581	1 1/4 IN. SK K	CUKT012	88.218	23.307	10 IN.	IR8S100	1.530	0.404			
2 1/2 IN.	PV8S025	21.833	5.768	1 1/4 IN. SK L		85.451	22.576	12 IN.	IR8S120	1.060	0.280			
3 IN.	PV8S030	13.541	3.578	1 1/2 IN. SK K	CUKT015	56.962	15.049	SCH 80 IRON SADDLE ON SCH 40 PIPE						
4 IN.	PV8S040	7.626	2.015	1 1/2 IN. SK L		55.160	14.573	2 IN.	IR8S020	26.820	7.086			
6 IN.	PV8S060	4.162	1.100	2 IN. SK K	CUKT020	29.370	7.759	2 1/2 IN.	IR8S025	18.800	4.967			
8 IN.	PV8S080	2.370	0.626	2 IN. SK L		28.605	7.558	3 IN.	IR8S030	11.990	3.168			
SCH 80 PVC SADDLE ON SCH 40 PVC PIPE				STAINLESS STEEL WELDOLETS ON SCH 40 PIPE				4 IN.				IR8S040	6.850	1.810
2 IN.	PV8S020	27.350	7.226	2 1/2 IN.	CR4W025	18.800	4.967	5 IN.	IR8S050	5.330	1.408			
2 1/2 IN.	PV8S025	18.874	4.987	3 IN.	CR4W030	12.170	3.215	6 IN.	IR8S060	3.760	0.993			
3 IN.	PV8S030	12.638	3.339	4 IN.	CR4W040	6.960	1.839	8 IN.	IR8S080	2.130	0.563			
4 IN.	PV8S040	6.728	1.778	5 IN.	CR4W050	5.260	1.390	10 IN.	IR8S100	1.350	0.357			
6 IN.	PV8S060	3.730	0.985	6 IN.	CR4W060	3.690	0.975	12 IN.	IR8S120	0.960	0.254			
8 IN.	PV8S080	2.153	0.569	8 IN.	CR4W080	2.130	0.563	CONVERSION FORMULAS						
CARBON STEEL TEES ON SCH 40 PIPE				10 IN.	CR4W100	1.350	0.357	1 U.S. gallon = 0.003785 cubic meters						
1/2 IN.	CS4T005	370.202	97.808	12 IN.	CR4W120	0.960	0.254	0.000003069 Acre feet						
3/4 IN.	CS4T007	212.063	56.027	CARBON STEEL WELDOLETS ON SCH 40 PIPE				8.3454 pounds of water						
1 IN.	CS4T010	141.138	37.289	2 1/2 IN.	CS4W025	18.800	4.967							
1 1/4 IN.	CS4T012	60.655	16.025	3 IN.	CS4W030	12.170	3.215							
1 1/2 IN.	CS4T015	45.350	11.982	4 IN.	CS4W040	6.960	1.839							
2 IN.	CS4T020	26.767	7.072	5 IN.	CS4W050	5.260	1.390							
STAINLESS STEEL TEES ON SCH 40 PIPE				6 IN.	CS4W060	3.690	0.975							
1/2 IN.	CR4T005	358.960	94.838	8 IN.	CS4W080	2.130	0.563							
3/4 IN.	CR4T007	202.610	53.530	10 IN.	CS4W100	1.350	0.357							
1 IN.	CR4T010	127.140	33.590	12 IN.	CS4W120	0.960	0.254							
1 1/4 IN.	CR4T012	61.910	16.357											
1 1/2 IN.	CR4T015	40.410	10.676											
2 IN.	CR4T020	22.300	5.892											

K-Factors DIN Pipes

PIPE SIZE	+GF+ SIGNET FITTING TYPE	----K-FACTOR----		CODE
		U.S. GAL	LITERS	
POLYPROPYLENE FITTINGS (DIN/ISO AND BS AND ANSI)				
DN 15	PPMT005	481.553	127.227	198.150.522
DN 20	PPMT007	277.089	73.207	198.150.523
DN 25	PPMT010	141.181	37.300	198.150.524
DN 32	PPMT012	83.540	22.071	198.150.525
DN 40	PPMT015	51.265	13.544	198.150.526
DN 50	PPMT020	29.596	7.819	198.150.527
DN 65	PPMT025	20.658	5.458	198.150.560
DN 80	PPMT030	13.330	3.522	198.150.561
DN 100	PPMT040	8.708	2.301	198.150.562
DN 125	PPMT050	5.067	1.339	198.150.563
DN 150	PPMT060	3.689	0.975	198.150.564
DN 200	PPMT080	2.040	0.539	198.150.565
PVDF FITTINGS (DIN/ISO AND BS AND ANSI)				
DN 15	SFMT005	420.868	111.194	198.150.529
DN 20	SFMT007	228.149	60.277	198.150.530
DN 25	SFMT010	136.697	36.116	198.150.531
DN 32	SFMT012	79.294	20.950	198.150.532
DN 40	SFMT015	43.490	11.490	198.150.533
DN 50	SFMT020	25.908	6.845	198.150.534
DN 65	SFMT025	18.067	4.773	198.150.571
DN 80	SFMT030	12.357	3.265	198.150.572
DN 100	SFMT040	8.060	2.129	198.150.573
DN 125	SFMT050	4.431	1.171	198.150.574
DN 150	SFMT060	3.227	0.853	198.150.575
DN 200	SFMT080	2.036	0.538	198.150.576

PIPE SIZE	+GF+ SIGNET FITTING TYPE	----K-FACTOR----		CODE
		U.S. GAL	LITERS	
PVC FITTINGS (DIN/ISO) - EUROPE ONLY				
DN 15	PVMT005	486.183	128.450	198.150.480
DN 20	PVMT007	242.846	64.160	198.150.481
DN 25	PVMT010	148.637	39.270	198.150.482
DN 32	PVMT012	85.125	22.490	198.150.483
DN 40	PVMT015	51.855	13.700	198.150.484
DN 50	PVMT020	29.750	7.860	198.150.485
DN 65	PVMT025	17.487	4.620	198.150.538
DN 80	PVMT030	12.491	3.300	198.150.539
DN 100	PVMT040	8.138	2.150	198.150.540
DN 150	PVMT060	4.088	1.080	198.150.543
DN 200	PVMT080	2.044	0.540	198.150.545

10. Order Information

Standard 515 Rotor-X Paddlewheel Flow Sensors						515 Accessories						
						All O-rings are Viton®						
Order No.	Sensor Body	Rotor Pin	Rotor	Pipe Size	Code	Order No.	Material	Code	Order No.	Rotor Pin	Material	Code
P51530-P0	Polypro.	Titanium	PVDF (black)	0.5 to 4.0 in.	198 801 620	M1538-2	PVDF (std.)	198 801 181	M1546-1	Titanium		198 801 182
P51530-P1	Polypro.	Titanium	PVDF (black)	5.0 to 8.0 in.	198 801 621	M1538-4	Tefzel	198 820 018	M1546-2	Hastelloy C		198 801 183
P51530-P2	Polypro.	Titanium	PVDF (black)	10 to 36 in.	198 801 622	P51546	Tefzel with sleeve	198 820 017	M1546-3	Tantalum		198 820 014
P51530-V0	PVDF (natural)	Hastelloy C	PVDF (natural)	0.5 to 4.0 in.	198 801 623	P51550-3	PVDF (natural) + Rotor Pin	198 820 043	M1546-4	Stainless steel		198 820 015
P51530-V1	PVDF (natural)	Hastelloy C	PVDF (natural)	5.0 to 8.0 in.	198 801 624				P51545	Ceramic		198 820 016
P51530-V2	PVDF (natural)	Hastelloy C	PVDF (natural)	10 to 36 in.	198 801 625				P51550-3	PVDF (natural) + Rotor		198 820 043
P51530-T0	PVDF (natural)	PVDF (natural)	PVDF (natural)	0.5 to 4.0 in.	198 801 663	Order No.	Material	Code	Order No.	Description	Code	
P51530-T1	PVDF (natural)	PVDF (natural)	PVDF (natural)	5.0 to 8.0 in.	198 801 664	O-Rings	Viton® (std.)	198 801 186	P31542	Sensor cap, PP	198 801 630	
P51530-T2	PVDF (natural)	PVDF (natural)	PVDF (natural)	10 to 36 in.	198 801 669	1220-0021	EPR	198 820 006	P31536	Plug, PP	198 840 201	
319 Wet-Tap Assembly Including Extended 515 Sensor						Rotor pin material is Titanium						
Order No.	Valve	Sensor Body	Rotor	Pipe Size	Code	1224-0021	Kalrez	198 820 007	P31536-2	Plug, PVDF (nat.) with std. cap	198 840 202	
MK319/515-P3	PVC	Polypro.	PVDF (black)	0.5 to 4.0 in.	198 840 119							
MK319/515-P4	PVC	Polypro.	PVDF (black)	5.0 to 8.0 in.	198 840 120							
MK319/515-P5	PVC	Polypro.	PVDF (black)	10 to 36 in.	198 840 121							
319 Wet-Tap Without 515 Sensor						+GF+ SIGNET 3-8510-XX Integral Sensor Accessories						
Order No.	Material	Description										
P31940	PVC	319 Wet-Tap										
Extended 515 Sensors for 319 Wet-Tap												
Order No.	Sensor Body	Rotor Pin	Rotor	Pipe Size	Code	Order No.	Description	Pipe Size	Code			
P51530-P3	Polypro.	Titanium	PVDF (black)	0.5 to 4.0 in.	198 840 310	3-8011	Integral sensor mounting kit with 1/2 in. NPT ports	0.5 to 4 inch	198 864 500			
P51530-P4	Polypro.	Titanium	PVDF (black)	5.0 to 8.0 in.	198 840 311	3-8011-D	Integral sensor mounting kit with PG 13.5 ports	5 to 8 inch	198 864 501			
P51530-P5	Polypro.	Titanium	PVDF (black)	10 to 36 in.	198 840 312	Order No.	Description	Pipe Size	Code			
						3-8510-P0	Integral sensor, Polypro.	0.5 to 4 inch	198 864 504			
						3-8510-P1	Integral sensor, Polypro.	5 to 8 inch	198 864 505			
						3-8510-V0	Integral sensor, PVDF (natural)	0.5 to 4 inch	198 864 506			

11. Rotor Replacement Procedure

- To remove the rotor, insert a small screwdriver between the rotor and the ear of the sensor.
- Twist the screwdriver blade to flex the ear outward enough to remove one end of the rotor and pin. **DO NOT** flex the ear any more than necessary! If it breaks, the sensor cannot be repaired.
- Install the new rotor by inserting one ear into the hole, then flex the opposite ear back enough to slip rotor into place.

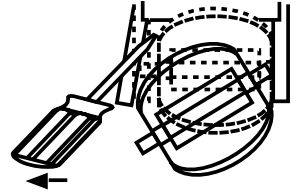

12. Specifications

General Data

Flow Rate Range:	0.3 to 6 m/s (1 to 20 ft/s)
Linearity:	±1% of maximum range
Repeatability:	±0.5% of maximum range
Pipe Size Range:	15 to 900 mm (0.5 to 36 in.)
Cable Length:	7.6 m (25 ft) can splice up to 60 m (200 ft) without amplification
Cable type:	2-conductor twisted pair with shield

Materials

Sensor Assembly: Various thermoplastics available. Refer to section 10 for details.

Electrical

Source Impedance: 8 kΩ

Quality Standards

- FM, CE
- Manufactured under ISO 9001

Fluid Conditions

515/3-8510-XX Sensor Pressure/Temperature Ratings:

- Polypropylene Body:
- 12.5 bar (180 psi) max. @ 20 °C (68 °F)
 - 1.7 bar (25 psi) max. @ 90 °C (194 °F)

PVDF Body:

- 14 bar (200 psi) max @ 20 °C (68 °F)
- 1.7 bar (25 psi) max @ 100 °C (212 °F)

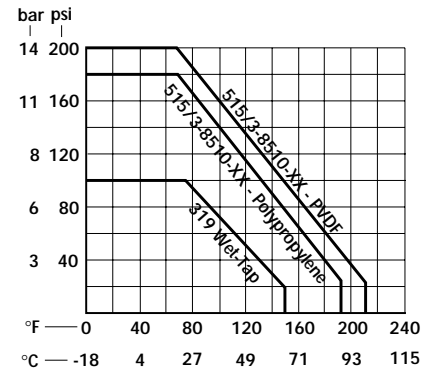

319 Wet-Tap Assembly Pressure/Temperature Ratings:

- 7 bar (100 psi) max. @ 25 °C (77 °F)
- 1.4 bar (20 psi) max. @ 66 °C (150 °F)

+GF+ SIGNET

Sales Offices:

USA	George Fischer, Inc., 2882 Dow Avenue, Tustin, CA 92780/USA, Tel. (714) 731-8800, Fax (714) 731-6201
Switzerland	George Fischer Rohrleitungssysteme AG, P.O. Box 671, CH-8201 Schaffhausen/Switzerland, Tel. 052/631 1111, Fax 052/631 2830
Singapore	George Fischer Pte. Ltd., 15 Kaki Bukit Road 2, KB Warehouse Complex, Singapore 1441, Tel. 65/747 0611, Fax 65/747 0577
Japan	Kubota George Fischer, 2-47 Shikitsuhigashi, 1-Chome, Naniwa-Ku, Osaka, 556-91 Japan, Tel. 816/648 2545, Fax 816/648 2565
China	Georg Fischer Ltd., Rm 1503, Business Residence Bldg. of Asia Plaza, 2-3 Bldg. No. 5th Qu Anzhenxili, Chaoyang Qu, Beijing 100029, P.R. China, Tel. 86/10 6443 0577, Fax 86/10 6443 0578
Australia	George Fischer Pty. Ltd., Suite 3, 41 Stamford Road, Oakleigh, Victoria 3166, Australia, Tel. 61/3 9568 0966, Fax 61/3 9568 0988

Signet Scientific Company, 3401 Aerojet Avenue, El Monte, CA 91731-2882 U.S.A., Tel. (626) 571-2770, Fax (626) 573-2057

GEORGE FISCHER +GF+ Piping Systems

P51590-1/(J-5/97), English

© Signet Scientific Company 1994



PRINTED ON RECYCLED PAPER
Printed in U.S.A.