



CAUTION!

- Refer to instruction manual for more details.
- Remove power to unit before wiring input and output connections.
- Follow instructions carefully to avoid personal injury.

Contents

- | | |
|---|------------------------------------|
| 1. Power Connections | 7. Parts and Accessories |
| 2. Compatible Electrode/Preamp Wiring | 8. Specifications |
| 3. 4 - 20 mA Current Output Connections | 9. Quick Reference Menu Parameters |
| 4. Relay Connections | 10. Troubleshooting |
| 5. Relay Operation | 11. Maintenance |
| 6. Menu Functions | |

1. Power Connections



CAUTION!

Never connect 110 VAC or 220 VAC to rear power terminals. High voltage AC will damage instrument and void warranty.

- = Double Insulated
- = DC or AC power

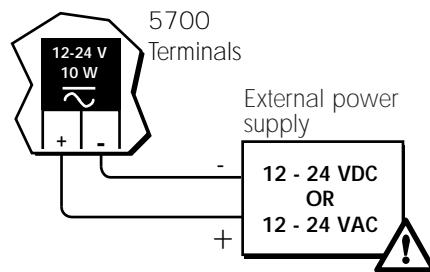

Technical Notes:

- To reduce the possibility of noise interference, isolate AC power lines from signal lines.
- Maximum 4-20 mA loop impedance (sec. 3) is affected by the supply voltage.

2. Compatible Electrode/Preamp Wiring

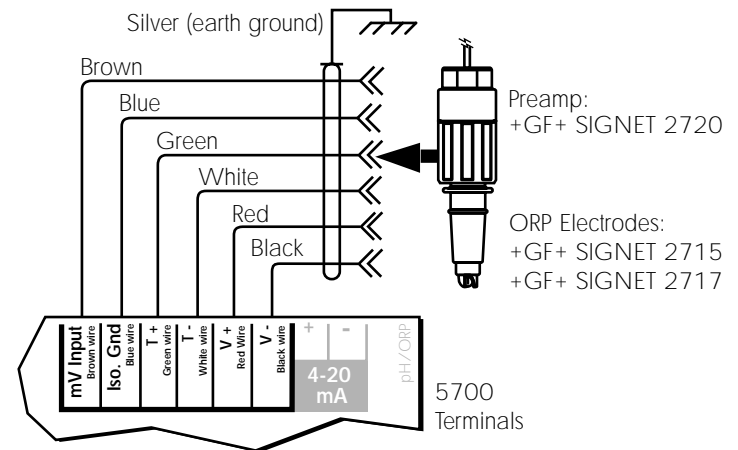

Technical Notes:

- Use six conductor shielded cable for cable extensions up to 120 m (400 ft) max. (#5523-0624)
- Cable shield must be maintained through cable splice

3. 4 - 20 mA Current Output Connections

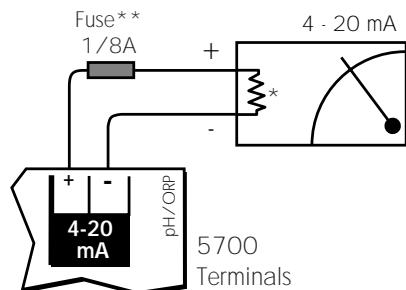

Technical Notes:

- ** 1/8A fuse recommended (customer supplied)
- * 4-20 mA output is **internally powered** (non-isolated), maximum loop impedance 350 Ω with a 12 V instrument supply voltage, 950 Ω with a 24 V instrument supply voltage.

To isolate output and prevent ground loop problems:

1. Use monitor device with isolated inputs, or
2. Use separate DC supply for 5700 and monitor device, or
3. Power 5700 with 12 - 24 VAC step down transformer

4. Relay Connections

Two internal relay contact sets (COM, NO, and NC) may be used for external device control. Front panel LED annunciators indicate the activation status of each relay. Each relay can control up to two devices simultaneously, as shown. Relay operation modes include Low alarm, High alarm, and Proportional Pulse (sec. 5).

Common device connections include:

- Pulse mode - metering pump control
- Pulse mode - solenoid valve control
- Low or High mode - warning lamps
- Low or High mode - bells or sirens
- Low or High mode - external heavy-duty relay

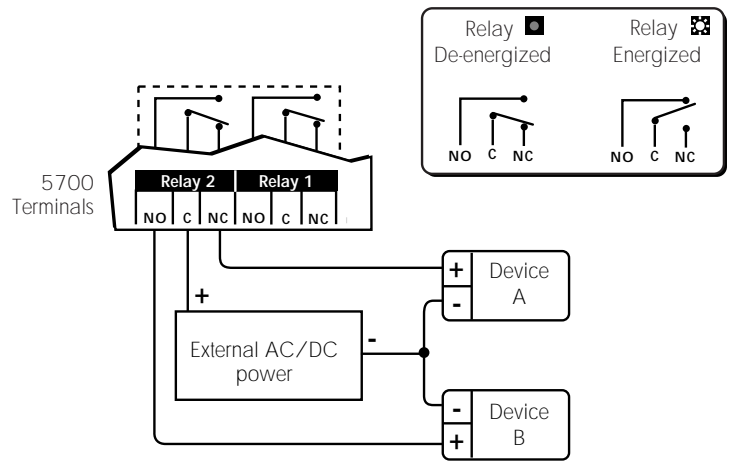

Wiring Example Right

Device A **IS** powered when relay 2 is de-energized (front panel LED "off"). Power is discontinued when the relay 2 setpoint is reached (front panel LED "on"). Device B **IS NOT** powered when the relay 2 is de-energized. Power is applied after the relay 2 setpoint is reached.

Technical Notes:

- Maximum relay contact ratings: 5 A @ 30 VDC, 5 A @ 125 VAC, or 3 A @ 250 VAC
- An external heavy-duty relay must be used for devices with surge currents or operating currents that exceed the above specifications.

5. Relay Operation

A. LOW alarm mode

The relay is energized when the ORP drops below the setpoint, and is de-energized when the ORP rises above the setpoint plus hysteresis (sec. 6.3D, 6.3E).

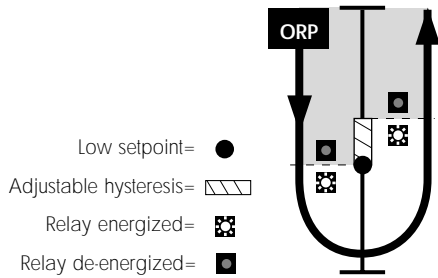

B. HIGH alarm mode

The relay is energized when the ORP rises above the setpoint and is de-energized when the ORP falls below the setpoint plus hysteresis (sec. 6.3D, 6.3E).

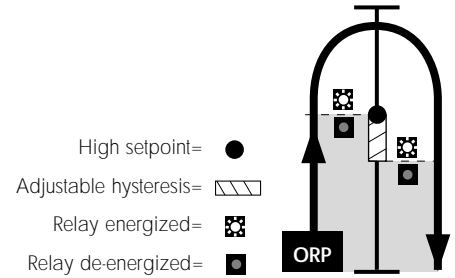

C. Proportional PULSE mode

The proportional pulse relay configuration is primarily designed for metering pump control. The operator is prompted to enter a minimum and maximum ORP setpoint and maximum pulse rate for the assigned relay (sec. 6.3F, 6.3G). Relay pulse width is fixed at 130 ms. Refer to the operation examples below.

- Metering pump chemical addition (dry contact activation type required)

Example 1 (right):

As the process ORP rises above the minimum pulse setpoint (-500 mV) the relay begins pulsing; triggering the metering pump for chemical addition. As the ORP continues to rise, pulsing accelerates proportionally until the maximum programmed pulse rate of 120 pulses/minute and setpoint (+500 mV) are reached, forcing the process ORP back down to intended levels (e.g. ≤ -500 mV).

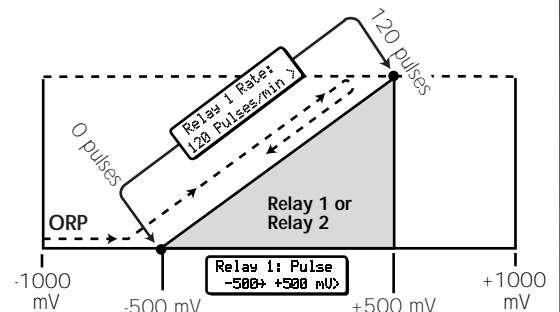

Example 2 (right):

As the process ORP falls below the minimum pulse setpoint (+500 mV) the relay begins pulsing; triggering the metering pump for chemical addition. As the ORP continues to decrease, pulsing accelerates proportionally until the maximum programmed pulse rate of 100 pulses/minute and setpoint (-500 mV) are reached, forcing the process ORP back up to intended levels (e.g. $\geq +500$ mV).

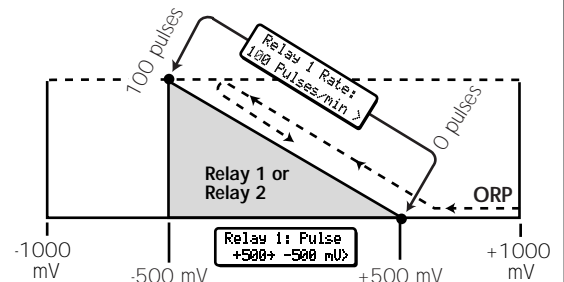

6. Menu Functions

To access either CALIBRATE or OPTIONS menus, press and hold the ENTER key as illustrated below:

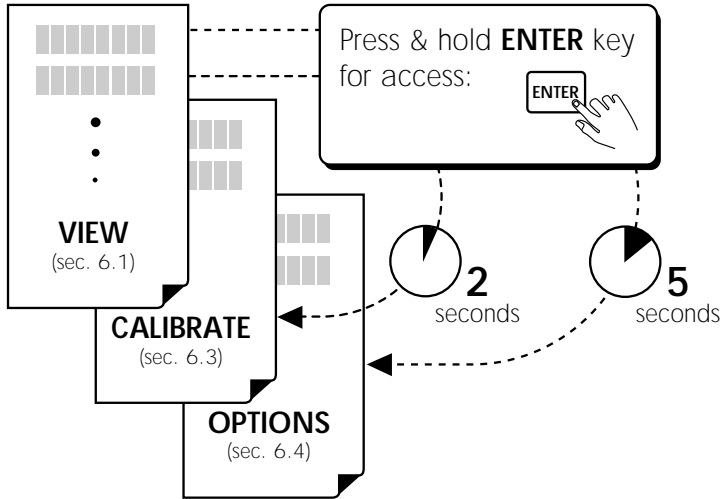

Menus:

- **VIEW menu (sec. 6.1):** The VIEW menu is displayed during standard operation. The operator can navigate freely through the menu by pressing either UP or DOWN arrow keys.
- **CALIBRATE Menu (sec. 6.3):** The CALIBRATE menu contains all critical display setup and output parameters. A simple security code feature prevents unauthorized tampering. The operator is required to enter a simple access code for menu access. The same code also unlocks OPTIONS menus.
- **OPTIONS Menu (sec. 6.4):** The OPTIONS menu contains setup and display features that are seldom accessed for minor display or output adjustments.

- **Reversible Dial**
Your 5700 includes a reversible dial face for pH use. See enclosed pH manual for operation details.

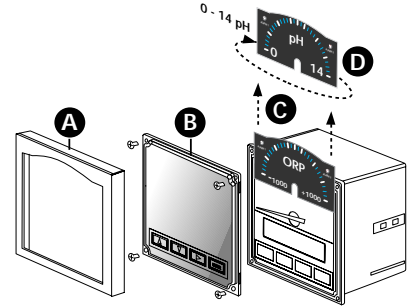

6.1 VIEW Menu

| 1 Choose: | 2 Change: | 3 Save: |
|--|--------------|--|
| ↓G ▲ ORP: +87 mV A. Input: +84 mV ORP mV/Raw mV | | |
| ▲ ▼ B. LOOP Output: 12.69 mA Loop output | | |
| ▲ ▼ C. Min→Max: mV -1000 → +1000 Range | | |
| ▲ ▼ D. Relay 1: Low -500 mV Relay 1 | | |
| ▲ ▼ E. Relay 2: High +500 mV Relay 2 | | |
| ▲ ▼ F. Last CAL: 01-01-98 Last calibration | | |
| ▲ ▼ G. EASY CAL: > Buffer calibration | | Press and release to access EASY CAL Procedure |

Menu Displays A - G:

(Factory default displays shown in menu column 1)













- A. Shows calibrated solution ORP mV and Raw (uncalibrated) input mV from ORP electrode/preamplifier
- B. Loop output display: shows the loop current output level.
- C. ORP range display: shows the programmed min and max meter range (sec. 6.3A)
- D. Relay 1 display: this display shows the programmed operation mode and setpoint for relay 1 (sec. 6.3D-E)
- E. Relay 2 display: this display shows the programmed operation mode and setpoint for relay 2 (sec. 6.3D-E)
- F. Last calibration: this display shows a user defined setup date for maintenance records. This feature is not an internal timer or calender.
- G. EASY CAL: press the right arrow key to access the EASY CAL buffer calibration procedure (sec. 6.2).

See EASY CAL Procedure (Section 6.2)

6.2 EASY CAL Procedure

Requirements

- This procedure simplifies system calibration using standard pH 4.0 and 7.0 buffers **saturated with Quinhydrone** (customer supplied). If standard pH 4.0 and 7.0 buffers and Quinhydrone are not available, the system can be calibrated using the CALIBRATE menu standard and slope settings (sec. 6.3B, 6.3C).
- Quinhydrone (customer supplied) is the oxidizer measured by the ORP electrode and is essential for EASY CAL calibration. To guarantee saturation with pH 4.0 and 7.0 buffers, mix 1/8 g (1/4 mL) of Quinhydrone powder for each 50 mL of pH buffer solution (sec. 7).

| | | |
|--|--|---|
| EASY CAL: ---- Press keys in sequence     to continue, Enter Key Code **** will appear during code entry. | | |
| 1 To Calibrate: | 2 Response: | 3 To Accept: |
| <p>Place Sensor in ORP Buffer #1</p> <p>Place electrode tip in first pH buffer saturated with Quinhydrone;</p>  <p>pH 7.0 ≈ 87 mV pH 4.0 ≈ 264 mV</p> | <p>* ORP: + 84 mV Input: + 82 mV</p> <p>Allow for stabilization</p>  <p>30 seconds*</p> | <p>* ORP: + 84 mV Input: + 82 mV</p> <p>Press  to accept first buffer calibration.</p> <p>ORP: + 87 mV Input: + 82 mV</p>  |
| <p>Place Sensor in ORP Buffer #2</p> <p>Place electrode tip in second (different) pH buffer saturated with Quinhydrone;</p>  <p>pH 4.0 ≈ 264 mV pH 7.0 ≈ 87 mV</p> | <p>* ORP: +262 mV Input: +260 mV</p> <p>Allow for stabilization</p>  <p>30 seconds*</p> | <p>* ORP: +262 mV Input: +260 mV</p> <p>Press  to accept second buffer calibration.</p> <p>ORP: +264 mV Input: +260 mV</p> <p>Display returns to VIEW Menu in 3s</p> |
| <p>To exit EASY CAL at any time without saving changes:</p>  quick press | | |

Displayed Data

- ORP mV: Shows the calibrated solution oxidation reduction potential (ORP).
- Input mV: Shows the actual Raw (uncalibrated) preamplifier ORP electrode input

*For best results, gently stir the submerged electrode for approximately 5 seconds during the stabilization period (step 2).

Technical Note:

The differences between input mV and ORP mV is a good indication of the electrode's condition. Differences in excess of 50 mV may indicate a need to service the electrode. Refer to electrode manual for maintenance recommendations.

6.3 CALIBRATE Menu

Requirements

System calibration is possible with two known ORP solutions within -1000 mV - +2000 mV. The EASY CAL procedure (sec. 6.2) is recommended when standard pH buffers and Quinhydrone are available. If EASY CAL is performed, manual calibration steps B - C below are not required and should be skipped.

| CALIBRATE: ---- Enter Key Code | | Press keys in sequence to continue, **** will appear during code entry. | | |
|--|---|--|-------------------------------------|--|
| 1 Choose: | 2 Change: | 3 Save: | | |
| A. Min→Max: mV -1000 → +1000 > Range | Min→Max: mV -1000 → +1000 Meter min→max | Min→Max: mV -0800 → +0800 | | |
| B. Set Standard: > Electrode standard | Input: +0084 mV ORP: +0085 mV Allow for stabilization | Input: +0084 mV ORP: +0087 mV | "SAVING" briefly displays | |
| C. Set Slope: Electrode slope | Input: +0260 mV ORP: +0262 mV Allow for stabilization | Input: +0260 mV ORP: +0264 mV | | |
| Relay Low or High Mode Selected | | | | |
| D. Relay 1: Low -500 mV > Relay | Relay 1: [Low] -0500 mV Mode Setpoint | Relay 1: Low -0400 mV | | |
| E. Relay 1 Hys: 10 mV > Relay | Relay 1 Hys: 00010 mV Hysteresis | Relay 1 Hys: 00050 mV | | |
| Relay Pulse Mode Selected, step D | | | | |
| F. Relay 1: Pulse -500 → +500 mV > Relay | Relay 1: [Pulse] -0500 → +0500 mV Mode Range | Relay 1: Pulse -0150 → +0550 mV | | |
| G. Relay 1 Rate: 120 Pulses/min > Relay | Relay 1 Rate: 120 Pulses/min Pulse rate | Relay 1 Rate: 025 Pulses/min | | |
| H. Last CAL: 01-01-98 > Last calibration | Last CAL: 01-01-98 Optional | Last CAL: 02-05-98 | | |
| To return to VIEW: quick press | To restore original value: quick press | | | |

Menu Settings A - H:

(Factory default displays shown in menu column 1)

- A. Sets Min → Max meter dial range, -1000 mV - +2000 mV (factory installed dial, -1000 mV - +1000 mV). Contact factory for custom dial configurations. **Does not effect 4 to 20 mA output**
- B. Sets electrode standard to any value from -1000 mV to +2000 mV (standard value must be ≥120 mV from slope value, step C)
- C. Sets electrode slope to any value from -1000 mV to +2000 mV (slope value must be ≥120 mV from standard value, step B)

Menu items D - G repeat for relay 2 setup.

- D. Sets relay operation mode Low or High, and ORP (mV) setpoint, -1000 mV - +2000 mV (sec. 5A-B)
- E. Sets relay hysteresis, 00000 - 02000 mV. Set to zero to disable feature (sec. 5A-B)
- F. Sets relay minimum and maximum pulse setpoint, -1000 mV - +2000 mV (sec. 5C)
- G. Sets relay pulse rate, 000 - 120 pulses/minute.
- H. Sets user defined setup date for maintenance records. This feature is not an internal timer or calendar

Quick Reference Calibration Procedures:

2-Point Quick Calibration (recommended):

1. Set solution standard (step B)
2. Set solution slope (step C)

1-Point Calibration (optional):

1. Set solution standard (step B)

6.4 OPTIONS Menu

OPTIONS: ---- Press keys in sequence **▲▲▲▼** to continue,
Enter Key Code **** will appear during code entry.

| 1 Choose: | 2 Change: | 3 Save: |
|---|--|--|
| A. Contrast: 3 > ▲ | Contrast: 1 2 3 4 5 Low - - - - High ▲▼▶ | Contrast: 1 2 3 4 5 |
| B. Set 4 mA: -1000 mV > ▶ | Set 4 mA: -1000 mV 4 mA setpoint ▲▼▶ | Set 4 mA: -0000 mV |
| C. Set 20 mA: +1000 mV > ▶ | Set 20 mA: +1000 mV 20 mA setpoint ▲▼▶ | Set 20 mA: +0000 mV |
| D. 4 mA Adjust: 4.00 mA > ▶ | 4 mA Adjust: 4.00 mA 4 mA adjust ▲▼▶ | 4 mA Adjust: 3.98 mA |
| E. 20 mA Adjust: 20.00 mA > ▶ | 20 mA Adjust: 20.00 mA 20 mA adjust ▲▼▶ | 20 mA Adjust: 19.98 mA |
| To return to VIEW: ▲▼ quick press | To restore original value: ▲▼ quick press |  "SAVING" briefly displays |

Menu Settings A - E:
 (Factory default displays shown in menu column 1)

- A. Selects display contrast: 5 levels
- B. Sets 4 mA setpoint: -1000 - +2000 mV. 4 mA and 20 mA setpoints are reversible
- C. Sets 20 mA setpoint: -1000 - +2000 mV. 20 mA and 4 mA setpoints are reversible
- D. Adjusts 4 mA output: 3.0 to 5.0 mA (overrides factory 4.00 mA calibration)
- E. Adjusts 20 mA output: 19 to 21 mA (overrides factory 20.00 mA calibration)

7. Parts and Accessories

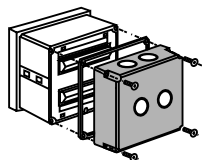

Splashproof rear cover
 #3-5000.395
 (code 198 840 227)

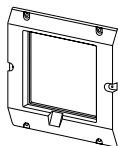

5 x 5 inch adapter plate for
 +GF+ SIGNET retrofit
 #3-5000.399
 (code 198 840 224)

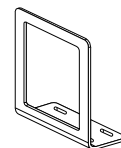

Optional surface mount
 bracket #3-5000.598
 (code 198 840 225)

- Power supply, 120 VAC - 24 VAC, #3-5000.075
- pH buffer kit, pH 4.0, 7.0, 10.0, #3-0700.390 (code 198 864 403)
- Front snap-on bezel, #3-5000.525 (code 198 840 226)
- 5700 pH/ORP instruction sheet, #3-5700.090-1 (code 198 869 915)

8. Specifications

General

Compatible sensors: +GF+ SIGNET 3-2720 pH/ORP Preamplifier/
Sensor System

Accuracy: $\pm 0.2\%$ of full scale

Input range:

- ORP: -1000 to +2000 mV, optically isolated
(standard -1000 to +1000 mV dial included)

Enclosure:

- Rating: NEMA 4X/IP65 front
- Dimensions: 1/4 DIN, 96 x 96 x 88 mm (3.8 x 3.8 x 3.5 in.)
- Case: ABS plastic
- Keypad: Sealed 4-key silicone rubber
- Weight: Approximately 500 g (18 oz.)

Display:

- Type: Microprocessor controlled air-core meter movement and backlit Alpha-numeric 2 x 16 LCD
- Update rate: <1s
- Contrast: User selected
- Relay annunciators: 2 LEDs

Environmental

Operating temp.: -10 to 55 °C (14 to 131 °F), 50 °C (122 °F) with optional rear cover

Storage temp.: -15 to 80 °C (5 to 176 °F)

Relative humidity: 0 to 95%, non-condensing

Altitude: 4000 m max.

Pollution degree: 2

Electrical

Power requirements:

- 12 to 24 VDC or 12 to 24 VAC, unregulated, 50-60 Hz, 10 W max.

Relay contacts (2 sets):

- Mechanical SPDT contacts
- Max. voltage rating: 5 A @ 30 VDC, 5 A @ 125 VAC, or 3 A @ 250 VAC, (power factor = 1.0)
- Hysteresis: User adjustable

Current output:

- 4 to 20 mA, non-isolated, internally powered, fully adjustable and reversible
- Update rate: <1s
- Max loop impedance: 350 Ω with a 12 V instrument supply voltage, 950 Ω with a 24 V instrument supply voltage
- Accuracy: $\pm 0.1\%$ of max. range

Noise immunity: EN50082-2

Noise emissions: EN55011

Safety: EN61010-1

Agency Approvals

- CSA, CE, UL listed
- Manufactured under ISO 9001

Dimensions

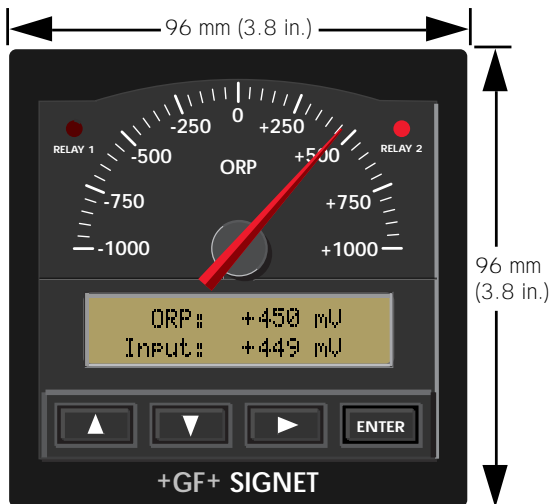

Front View

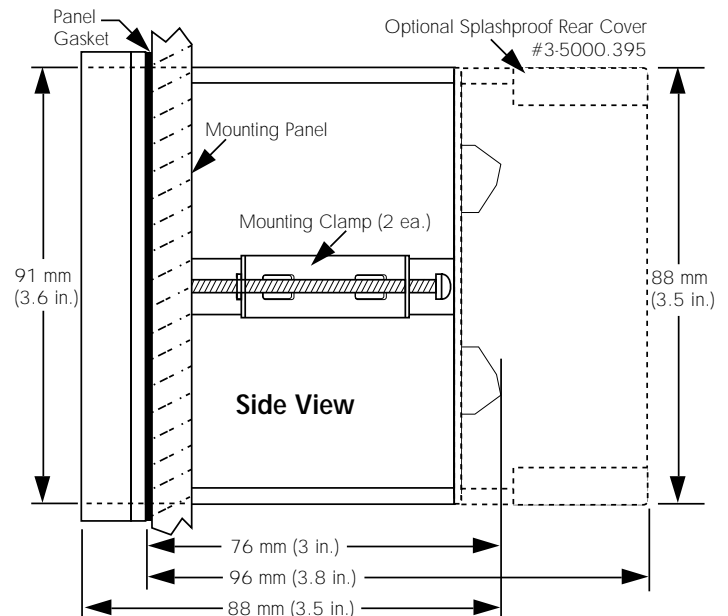

(continued)

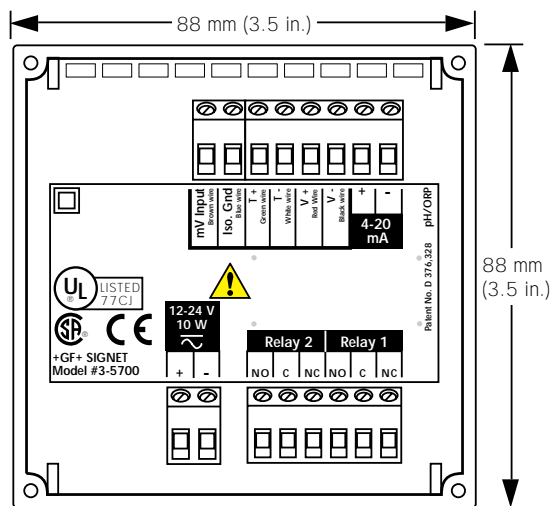

Rear View

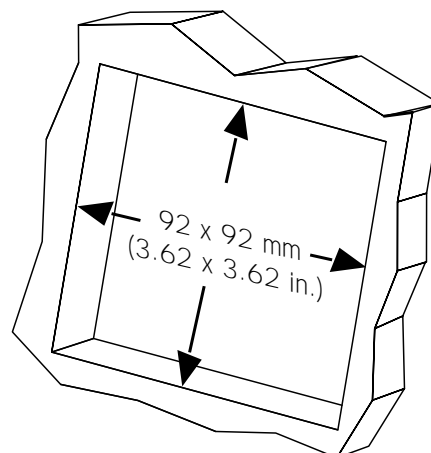

Panel cutout

9. Quick Reference Menu Parameters

9.1 VIEW Menu Setup Parameters (sec. 6.1)

| Menu Parameters | Display Description | Range | Factory Default |
|---------------------------------|--|--|---------------------|
| A. ORP: +87 mV Input: +84 mV | <ul style="list-style-type: none"> ORP mV Raw sensor mV | <ul style="list-style-type: none"> -1000 mV - +2000 mV -1000 mV - +2000 mV | n/a n/a |
| B. Loop Output: 12.69 mA | Current loop output | 3 - 21 mA | n/a |
| C. Min→Max: mV -1000 → +1000 | Min → Max meter and dial range | -1000 mV - +2000 mV | -1000 mV - +1000 mV |
| D. Relay 1: Low -500 mV | <ul style="list-style-type: none"> Relay 1 mode Relay 1 setpoint | Low, High, or Pulse, -1000 - +2000 mV | Low -500 mV |
| E. Relay 2: High +500 mV | <ul style="list-style-type: none"> Relay 2 mode Relay 2 setpoint | Low, High, or Pulse, -1000 - +2000 mV | High +500 mV |
| F. Last CAL: 01-01-98 | Last calibration date | 00 - 00 - 00 - 39 - 39 - 99 | 01 - 01 - 98 |
| G. EASY CAL: CAL: > | EASY CAL procedure | Two pH buffers saturated with Quinhydrone required: pH 4= +87 mV, pH 7= +264 mV, (sec. 6.2) | n/a |

9.2 CALIBRATE Menu Setup Parameters (sec. 6.3)

| Menu Parameters | Display Description | Range | Factory Default |
|---------------------------------------|--|---------------------------------|----------------------|
| A. Min→Max: mV -1000 → +1000 > | Min → max meter/dial range | -1000 - +2000 mV | -1000 - +1000 mV |
| B. Set Standard: > | Manual electrode standard calibration | -1000 - +2000 mV | n/a |
| C. Set Slope: | Manual electrode slope calibration | -1000 - +2000 mV | n/a |
| D. Relay 1: Low -500 mV > | <ul style="list-style-type: none"> Relay 1 mode Relay 1 setpoint | Low or High -1000 - +2000 mV | Low -500 mV |
| E. Relay 1 Hys: 10 mV > | Relay 1 hysteresis | 00000 - 02000 mV | 10 mV |
| F. Relay 1: Pulse -500 → +500 mV > | <ul style="list-style-type: none"> Relay 1 mode Relay 1 range | Pulse -1000 - +2000 mV | -500 - +500 mV |
| G. Relay 1 Rate: 120 Pulses/min > | Relay 1 pulse rate | 000 - 120 pulses/minute | 120 pulses/minute |
| H. Last CAL: 01-01-98 > | Last calibration date | 00 - 00 - 00 - 39 - 39 - 99 | 01 - 01 - 98 |

*Relay mode and
setpoint displays
repeat for relay 2
setup*

9.3 OPTIONS Menu Setup Parameters (sec. 6.4)

| Menu Parameters | Display Description | Range | Factory Default |
|--------------------------------|---------------------|---------------------|-----------------|
| A. Contrast: 3 > | Display contrast | 0 to 5 | 3 |
| B. Set 4 mA: -1000 mV > | 4 mA setpoint | -1000 - +2000 mV | -1000 mV |
| C. Set 20 mA: +1000 mV > | 20 mA setpoint | -1000 - +2000 mV | +1000 mV |
| D. 4 mA Adjust: 4.00 mA > | 4 mA adjust | 3.0 to 5.0 mA | 4.00 mA |
| E. 20 mA Adjust: 20.00 mA > | 20 mA adjust | 19 to 21 mA | 20.00 mA |

10. Troubleshooting

| Display | Problem | Solution |
|--|--|--|
| 1. 7.04 pH +25.0 °C (Example↑) | pH electrode installed in preamplifier | Remove pH electrode and replace with recommended ORP electrode (sec. 2). |
| 2. CHECK SENSOR ? | Electrode not installed in preamplifier mV input from preamplifier out of range (≤ -1000 mV) Missing or wrong electrode identification resistance applied to rear T+ and T- terminals. | 1) Verify preamplifier/electrode input connections and electrode installation (sec. 2). 2) Disconnect Green and White preamplifier wires from rear T+ and T- terminals. Measure ORP electrode identification resistance across disconnected wires for $9.0\text{ k}\Omega - 10.8\text{ k}\Omega$. If measured resistance is out of range: <ul style="list-style-type: none"> • Wrong electrode installed in preamplifier (pH electrode = $3\text{ k}\Omega @ 25\text{ }^\circ\text{C}$ ($77\text{ }^\circ\text{F}$)) • Faulty preamplifier contacts, see preamplifier manual for additional information • Faulty electrode, see electrode manual for additional information 3) To verify instrument: <ul style="list-style-type: none"> • Disconnect Green and White preamplifier wires from rear T+ and T- terminals, then install a $10\text{ k}\Omega$ fixed resistor across the terminals. • Disconnect Brown and Blue preamplifier wires from rear mV Input and Iso. Gnd terminals. Install shorting strap (jumper) across mV Input and Iso. Gnd terminals. • Power instrument and verify 0 mV on the "Input mV" display (sec. 6.3B). If 0 mV ± 5 mV are not displayed, the instrument requires factory calibration. If "Input mV" are within ± 5 mV, calibrate instrument "Set Standard" for 0 mV (sec. 6.3B). • If instrument displays correctly after calibration, instrument is ok; preamplifier and/or electrode problem exists. Refer to preamplifier and electrode manual for troubleshooting information. |
| 3. Out Of Range Use Manual Cal | pH buffers other than pH 4 and 7 saturated with Quinhydrone used during EASY CAL procedure; pH 4= +87 mV, pH 7= +264 mV | Use pH 4 and 7 buffers (ONLY) saturated with Quinhydrone for EASY CAL procedure (sec. 6.2). The EASY CAL procedure simplifies manual Standard and Slope calibration in the CALIBRATE Menu (sec. 6). The instrument can be calibrated using two buffers of known ORP by this method (sec. 6.3B, 6.3C). If manual calibration is performed, the EASY CAL procedure is not required. |
| 4. ! Same Buffer | Same pH buffer used for EASY CAL solution #1 and solution #2 | Use different buffer saturated with Quinhydrone for EASY CAL procedure solution #1 and solution #2 (sec. 7). Do not calibrate both points with the same buffer! |
| 5. ORP: +2000 mV Input: +2000 mV (display stuck at +2000 mV) | Excessive mV input from preamplifier | Faulty preamplifier, refer to preamplifier manual for additional information To verify instrument input: <ul style="list-style-type: none"> • Disconnect Brown and Blue preamplifier wires and install shorting strap (jumper) across rear mV input and Iso Gnd terminals. • Power instrument and verify 0 mV on display. If 0 mV is not displayed, calibrate Standard input for 0 mV (sec. 6.3B) • If instrument displays correctly after calibration, instrument is ok. If error condition persists, instrument requires factory service. |

(continued)

| Display | Problem | Solution |
|---------------------------------------|--|---|
| 6. ! ORP must be 2000 or less | ORP (mV) input greater than +2000 mV, or improperly entered during Standard or Slope calibration | A) Use solution of known ORP within -1000 - +2000 mV range B) Enter mV value within -1000 mV - +2000 mV during standard or slope calibration (sec. 6.3B, 6.3C) |
| 7. Slope Too Close To Standard | ORP slope calibration too close to ORP standard calibration | (CALIBRATE Menu sec. 6.3 only) Calibrate ORP slope using an ORP solution ≥ 120 mV from the ORP standard solution (sec. 6.3C). |
| 8. Value Must Be -1000 Or More | Relay, 4 mA, or 20 mA ORP (mV) setpoint entered out of range | Enter ORP setpoint within -1000 - +2000 mV range (sec. 6.3, 6.4) |
| 9. Value Must Be 2000 Or Less | Relay, 4 mA, or 20 mA ORP (mV) setpoint entered out of range | Enter ORP setpoint within -1000 - +2000 mV range (sec. 6.3, 6.4) |
| 10. Value Must Be 120 Or Less | Relay pulse setting greater than 120 pulses per minute | Enter relay pulse setting within 0 - 120 pulses per minute (sec. 6.3F) |
| 11. SETUP READ ERROR Press any Key | Power fault occurred while saving setup menu entry | Press any key to reload factory defaults then reprogram system setup parameters. |

11. Maintenance

Clean the instrument case and front panel with a soft cloth and a mild soap solution.

Notes:

+GF+ SIGNET

Sales Offices:

- USA** George Fischer, Inc., 2882 Dow Avenue, Tustin, CA 92780/USA, Tel. (714) 731-8800, Fax (714) 731-6201
- Switzerland** Georg Fischer Rohrleitungssysteme AG, P.O. Box 671, CH-8201 Schaffhausen/Switzerland, Tel. 052/631 1111, Fax 052/631 2830
- Singapore** George Fischer Pte. Ltd., 15 Kaki Bukit Road 2, KB Warehouse Complex, Singapore 1441, Tel. 65/747 0611, Fax 65/747 0577
- Japan** Kubota George Fischer, 2-47 Shikitsuhigashi, 1-Chome, Naniwa-Ku, Osaka, 556-91 Japan, Tel. 816/648 2545, Fax 816/648 2565
- China** Georg Fischer Ltd., Rm 1503, Business Residence Bldg. of Asia Plaza, 2-3 Bldg. No. 5th Qu Anzhenxili, Chaoyang Qu, Beijing 100029, P.R. China, Tel. 86/10 6443 0577, Fax 86/10 6443 0578
- Australia** George Fischer Pty. Ltd., Suite 3, 41 Stamford Road, Oakleigh, Victoria 3166, Australia, Tel. 61/3 9568 0966, Fax 61/3 9568 0988

Signet Scientific Company, 3401 Aerojet Avenue, El Monte, CA 91731-2882 U.S.A., Tel. (626) 571-2770, Fax (626) 573-2057

GEORGE FISCHER +GF+ Piping Systems
3-5700.090-1/(F-1/98), English/ORP

© Signet Scientific Company 1995



PRINTED ON RECYCLED PAPER
Printed in U.S.A.