



CAUTION!

- Remove power to unit before wiring input and output connections.
- Follow instructions carefully to avoid personal injury.

Contents

1. Installation
2. Specifications
3. Electrical Connections
4. Menu Functions



1. Installation

The transmitter is available in two versions: a panel mount version, and an integral version for installation near the sensor (universal assembly)

1.1 Panel Installation

The Panel Mounting kits are supplied with the hardware to install instrumentation into panels and maintain a NEMA 4X watertight seal.

1. Punch out panel and de-burr edges. Recommended clearance on all sides between instruments is 1 inch.
2. Place gasket on instrument, and install in panel.
3. Slide mounting bracket over back of instrument until quick-clips snap into latches on side of instrument.
4. Connect wires to terminals.
5. To remove, secure instrument temporarily with tape from front or grip from rear of instrument. DO NOT RELEASE. Press quick-clips outward and remove.

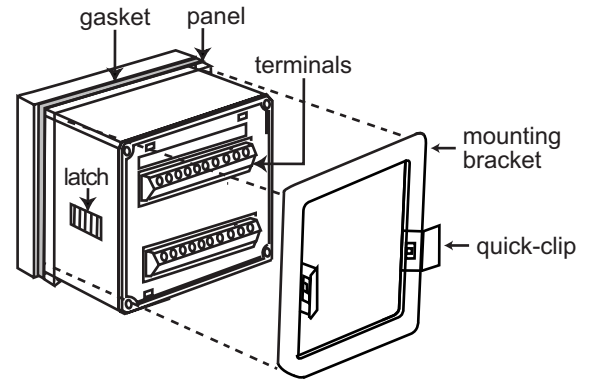

1.2 Universal Assembly (3-8050)

1. Install transmitter base
2. Connect wires to transmitter.
3. Close unit and secure with push and twist lock. Seal cable entry.

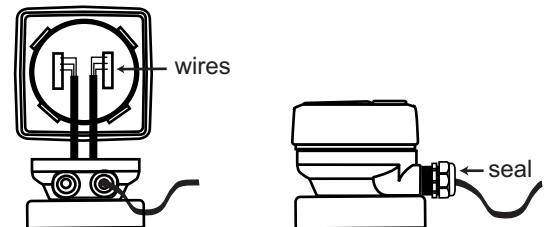

2. Specifications

General

Compatible electrodes: +GF+ SIGNET 3-2720 pH/ORP

Preamplifier/Electrode

Accuracy: ± 0.03 pH, ± 2 mV's ORP

Enclosure:

- Rating: NEMA 4X/IP65 front
- Case: PBT
- Window: Polyurethane coated polycarbonate
- Keypad: Sealed 4-key silicone rubber
- Weight: Approx. 325g (12 oz.)

Display:

- Alphanumeric 2 x 16 LCD
- Contrast: User selected, 5 levels
- Update rate: 1 second

Environmental

Operating temperature: -10 to 70°C (14 to 158°F)

Storage temperature: -15 to 80°C (5 to 176°F)

Relative humidity: 0 to 95%, non-condensing

Standards and Approvals

- CSA, CE, UL listed
- Manufactured under ISO 9001

Electrical

Sensor input range:

- pH: 0.00 to 14.00 pH
- temp. 3K Balco, -25 to 120°C (-13 to 248°F)
- ORP: -1000 to +2000 mV, isolated (10K Ω I.D. resistance T+, T-)

Current output:

- 4 to 20 mA, isolated, fully adjustable and reversible
 - Power: 12 to 24 VDC $\pm 5\%$, regulated
 - Max loop impedance: 50 Ω max. @ 12 V, 325 Ω max. @ 18 V, 600 Ω max. @ 24 V
 - Update rate: 0.5 seconds
 - Accuracy: ± 0.03 mA @ 25°C, 24 V
- Open-collector outputs: Hi, Lo, Pulse Programmable
- Open-collector, isolated, 50 mA sink or source, 30 VDC max. pull-up voltage

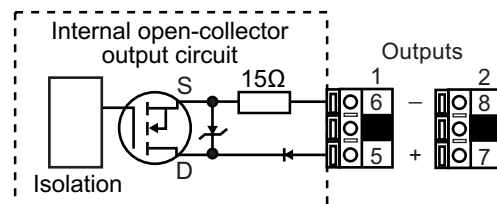

Dimensions

Panel Mount

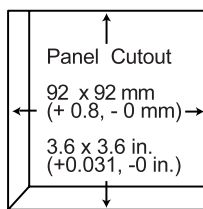
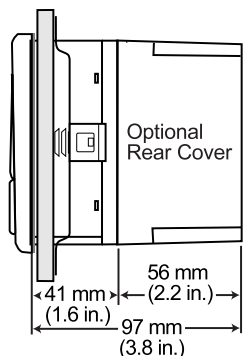
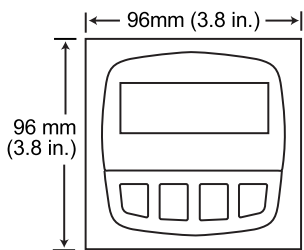

Field Mount

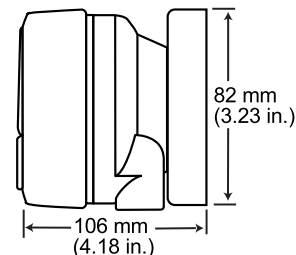
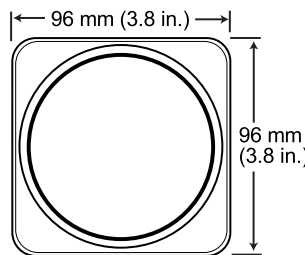

3. Electrical Connections

Caution: Failure to fully open terminal jaws before removing wire may permanently damage instrument.

Wiring Procedure

1. Remove 0.5 - 0.625 in. (13-16 mm) of insulation from wire end.
2. Press the orange terminal lever downward with a small screwdriver to open terminal jaws.
3. Insert exposed (non-insulated) wire end in terminal hole until it bottoms out.
4. Release orange terminal lever to secure wire in place. Gently pull on each wire to ensure a good connection.

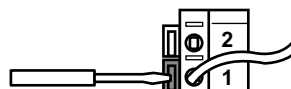

Wiring Removal Procedure

1. Press the orange terminal lever downward with a small screwdriver to open terminal jaws.
2. When fully open, remove wire from terminal.

System Power/Loop

1. System Power/Loop 1 +
2. System Power/Loop 1-
3. Loop 2+
4. Loop 2-

Description

12-24 VDC $\pm 5\%$, system power and current loop connections.
Max. loop impedance: 50 Ω max. @ 12 V, 325 Ω max. @ 18 V,
600 Ω max. @ 24 V

Open Collector Output

5. Output 1+
6. Output 1 -
7. Output 2+
8. Output 2-

Open-collector transistor output programmable as:

- High/Low alarm with adjustable hysteresis
- Proportional pulse output
- Disable (Off) selection

Preamplifier/Sensor Input

9. Red (V+)
10. Black (V-)
11. Shield (Sensr GND)
12. Earth GND
13. Brown (mV input)
14. Blue (ISO GND)
15. Green (Temp+)
16. White (Temp-)

Preamplifier positive
Preamplifier negative
Preamplifier shield
Connect if electrical noise is present
Preamplifier mV output
Preamplifier ground
TC element (3K Balco pH, 10K Ω ORP ID resistance)
TC element (3K Balco pH, 10K Ω ORP ID resistance)

4	Loop 2 -
3	Loop 2 +
2	System Pwr Loop 1 -
1	System Pwr Loop 1 +

8	Output 2-
7	Output 2+
6	Output 1-
5	Output 1+

16	Temp - (WHITE)
15	Temp + (GREEN)
14	Iso. GND (BLUE)
13	mV Input (BROWN)

12	Earth GND
11	Sensr Gnd (SHIELD)
10	V- (BLACK)
9	V+ (RED)

Wiring Tips:

- Do not route sensor cable in conduit containing AC power wiring - electrical noise may interfere with sensor signal.
- Routing sensor cabling in grounded metal conduit may prevent moisture damage, electrical noise, and mechanical damage.
- Seal cable entry points to prevent moisture damage.
- When placing two wire ends into a single terminal, solder or crimp ends together.

3.1 System Power/Loop Connections

Stand-alone application, no current loop used

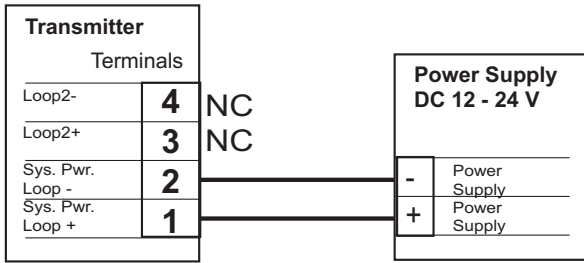

Connection to a PLC with built-in power supply

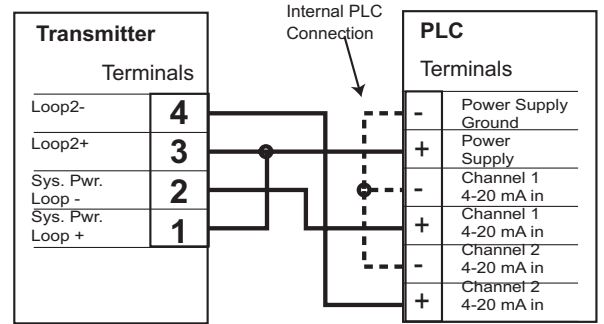

Connection to a PLC/Recorder, separate supply

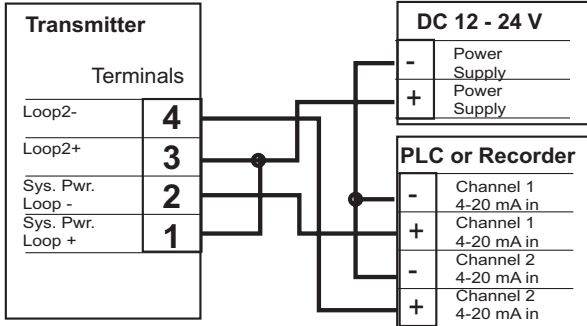

Example: Two transmitters connected to PLC/Recorder with separate power supply

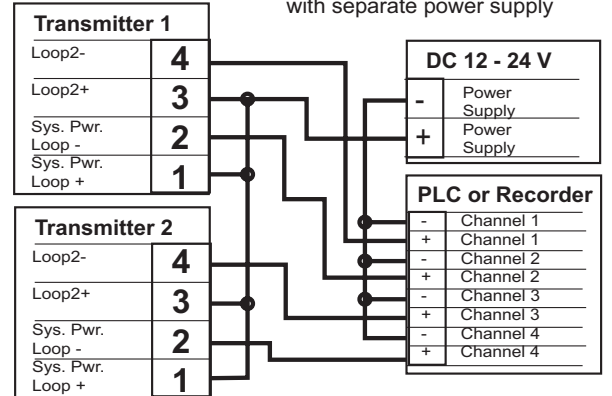

3.2 Sensor Input Connections

Wiring Tip:

Do not route sensor cable in any conduit containing AC power wiring - electrical noise may interfere with the signal.

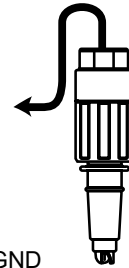
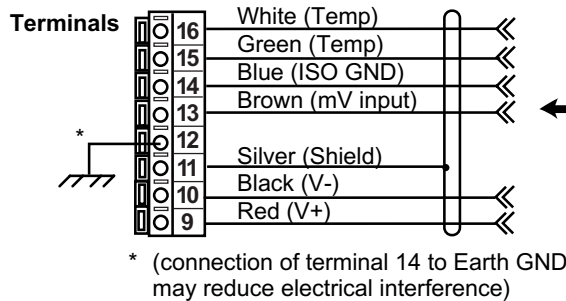

Preamp:
+GF+ SIGNET 2720

pH Electrodes
+GF+ SIGNET 2714, 2714-HF
+GF+ SIGNET 2716

ORP Electrodes:
+GF+ SIGNET 2715
+GF+ SIGNET 2717

3.3 Output Functions

- **Low:** Output triggers when process variable is less than setpoint.
- **High:** Output triggers when process variable is higher than setpoint.

Example: In Low Alarm Mode Operation, the output becomes active when the process drops below the setpoint, and becomes inactive when the process rises above the setpoint plus hysteresis. The opposite is true for High Alarm Mode.

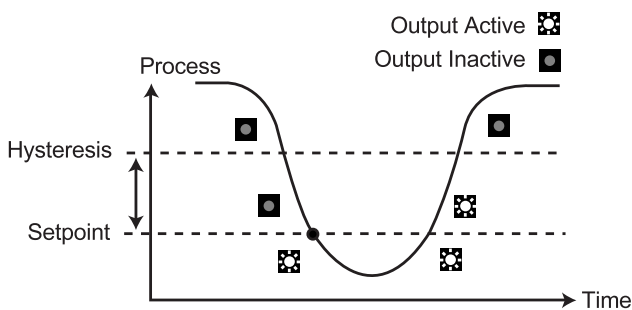

- **Disable:** Disables output.
- **Proportional Pulse Mode Operation**
The output emits a 100 mS pulse (simulated contact closure) at rate defined by the Output, Pulse Range, Output Rate, and the process condition (0 to 400 pulses/minute, as programmed)
Example: As the process falls below 10° the output will start pulsing in relation to the process value, the max pulse endpoint and the programmed pulses/min. Pulse rate will increase as the process approaches the programmed endpoint.

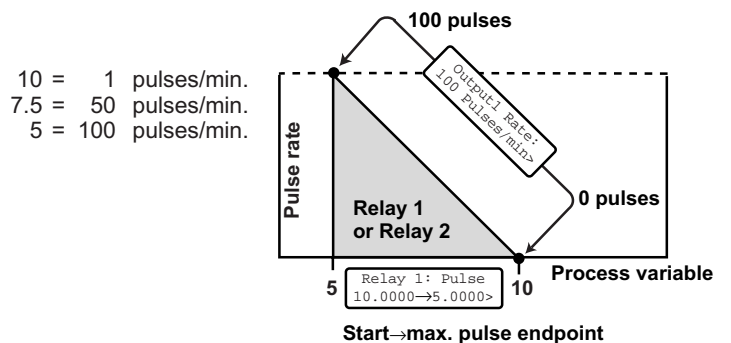

4. Menu Functions - pH

VIEW Menu: is displayed during standard operation.

- Press UP or DOWN buttons to view process parameters.
- Press UP and DOWN buttons at the same time, to exit any other display and return to VIEW menu.
- Display will return to VIEW menu in 10 minutes unless a key is pressed.

CALIBRATE Menu: contains display setup and output parameters. A security code feature prevents unauthorized tampering. To access CALIBRATE menu:

- Press ENTER button for 2 seconds to display:
- Press UP, UP, UP, DOWN buttons in sequence to display:

CALIBRATE: ----
Enter Key Code

CALIBRATE: XXXX
Enter Key Code

OPTIONS Menu: contains setup and display features for minor display or output adjustments. To access OPTIONS menu:

- Press ENTER button for 5 seconds to display:
- Press UP, UP, UP, DOWN buttons in sequence to display:

OPTIONS: ----
Enter Key Code

OPTIONS: XXXX
Enter Key Code

Menu Tips

- Right button scrolls to right, from top to bottom row, and allows editing when ">" symbol is shown.
- In CALIBRATE or OPTIONS menus, the transmitter will continue to measure and control outputs. When > is pressed, the input value is held at the last measured process value.
- When sensor is not connected, unit will display CHECK SENSOR and any output controlled by sensor will be at 3.6 mA or OFF.

Example

To change date, first enter CALIBRATE menu (Press ENTER button for 2 seconds; Press UP, UP, UP, DOWN buttons in sequence) Once in CALIBRATE menu, press UP button 1 time.

1. Display shows right arrow

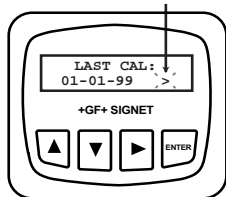

2. Press RIGHT button to display "01" blinking

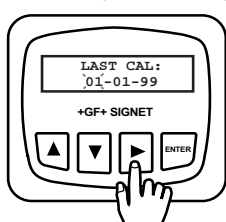

3. Press buttons to scroll through numbers.

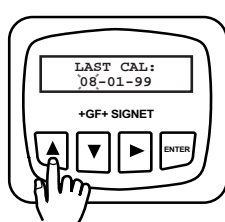

4. Press ENTER button to save

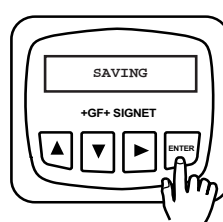

5. Display now reads new date

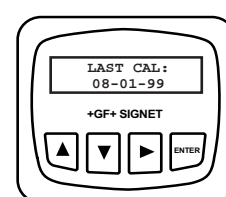

Menu Functions - pH

View Menu	Range
pH:	0-15 pH
Temp:	0 - 100°C
Input:	± 999 mV
Loop1 Output:	4-20 mA
Loop2 Output:	4-20 mA
Last Cal:	00-00-00
Date	to 39-39-99
Easy Cal:	Buffer solutions 4, 7, 10

Calibrate Menu	Range	Preset
Set: Temperature >	± 25°C	N/A
Set: Standard >	0-14 pH	N/A
Set: Slope >	0-14 pH	N/A
Loop1 Range: pH 0.00 -> 14.00 > (4mA) (20 mA)	0-14 pH	0->14 pH
Loop2 Range: °C 0.0 -> 100.0 > (4mA) (20 mA)	0-100 °C (32-212 °F)	0-100 °C (32-212 °F)

Options Menu	Range	Preset
Contrast: Level >	1-5	3
Averaging: Off >	Off Low (4secs) High (8secs)	Off
Output1 Active: Low >	Low High	Low
Output2 Active: Low >	Low High	Low
Temp Display: °C >	°C °F	°C
Loop1 Adjust: 4.00 mA >	3.8 to 5.0 mA	4.00 mA
Loop 1 Adjust: 20.00 mA >	19.0 to 21.0 mA	20.00 mA
Loop2 Adjust: 4.00 mA >	3.8 to 5.0 mA	4.00 mA
Loop 2 Adjust: 20.00 mA >	19.0 to 21.0 mA	20.00 mA
Test Loop1: >	4-20 mA	N/A
Test Loop2: >	4-20 mA	N/A
Test Output1: >	On or Off	N/A
Test Output2: >	On or Off	N/A

Output1 Source: pH >	pH or Temp.	pH (Output1) Temp (Output2)
Output1 Mode: Low >	Off Low Hi Pulse	Low (Output1) Hi (Output2)

Low or High selected

Output1 Setpnt: 4.00 pH >	0-14 pH	4.0 pH (Output1) 45°C (Output2)
Output1 Hys: 0.50 pH >	0-14 pH	0.5 pH (Output1) 1.0 °C (Output2)

Pulse selected

Output1 Range: pH 4.00 -> 10.00 > (Start>Endpoint)	0-14 pH	4 ->10 pH (Output1) 45 ->80°C (Output2)
Output1 PlsRate: 120 pulses/min >	0-400 pulses/min	120 pulses/min

Last Cal: 01-01-99 >	00-00-00 to 39-39-99	01-01-99
----------------------	----------------------	----------





Settings repeat for Output2

EASY CAL Procedure - pH

This procedure simplifies system calibration using standard pH buffers. Use 4.0, 7.0, 10.0 pH buffers only. If standard pH buffers are not available, the system can be calibrated using the CALIBRATE menu STANDARD and SLOPE settings. Access CALIBRATE menu and set sensor temperature before performing EASY CAL for new electrode installations.

EASY CAL: ----
Enter Key Code

Press UP, UP, UP, DOWN buttons in sequence to enter menu,
XXXX will appear during code entry.

To Calibrate:	Response:	To Accept:
<p>Place Sensor in pH Buffer #1</p>  <p>Place electrode tip in first pH buffer pH 7.0 = 0 mV pH 4.0 = 177 pH 10 = -177 Limit ± 50 mV</p>	<p>6.90 pH -005 mV</p> <p>Allow for stabilization</p>  <p>30 seconds*</p>	<p>6.90 pH -005 mV</p> <p>ENTER to accept</p> <p>7.00 pH -005 mV</p>
<p>Place Sensor in pH Buffer #2</p>  <p>Place electrode tip in second pH buffer.</p>	<p>3.93 pH +179 mV</p> <p>Allow for stabilization</p>  <p>30 seconds*</p>	<p>3.93 pH +179 mV</p> <p>Press ENTER to accept second buffer calibration.</p> <p>4.00 pH +179 mV</p>
<p>To exit menus and return to VIEW press UP and DOWN button at the same time</p> 	<p>Display returns to VIEW Menu in 10 minutes or when ENTER is pressed</p>	<p>Good Easy Cal Press <ENTER></p>

* For best results, gently stir the submerged electrode for approximately 5 seconds during the stabilization period.

Large temperature differences from process fluids to buffers may require longer stabilization time.

Theoretical mV values

pH @ 25°C	mV
2	+296
3	+237
4	+177
5	+118
6	+59
7	+0
8	-59
9	-118
10	-177
11	-237
12	-296

Technical notes:

The difference between the actual mV and value shown is a good indication of the condition of the electrode. Differences in excess of 50 mV may indicate a need to service the electrode.

Troubleshooting - pH

Display	Problem	Solution
+ ---- ----	Over or under range	Verify
Check Sensor ?	No sensor detected You may enter the CALIBRATION and OPTIONS menu to program setpoint values even though Check Sensor? is displayed.	Connect sensor/preamplifier or proper resistance for unit of measure. 3KΩ for pH.
Out of Range Check Sensor	Electrode not installed in preamplifier	1. Install sensor in preamp 2. Verify 3K Balco connection to transmitter (White/Green wires from preamplifier)
Out of Range Use Manual CAL	1. Did not use pH 4, 7, 10 buffers 2. Excessive probe mV offset	1. Use pH 4, 7, 10 buffers 2. Clean probe and retry EASY CAL. Use Manual calibration for Standard and Slope if mV offset exceeds 50 mV.
! Same Buffer (EasyCal only)	Same buffer used for Standard and Slope.	Place probe in alternate buffer solution.
15.00 pH Temperature or 0.00 pH Temperature	Excessive positive or negative mV input from preamplifier	1. Verify preamplifier wiring 2. Check preamplifier with 2719 preamplifier tester. 3. Disconnect preamp. "Out of Range Check Sensor" should appear
Standard too close to Slope !	1. pH Standard value within 2 pH units (120 mV) of Slope value 2. Probe efficiency is too small	1. Use pH values with a greater difference in reading. 4,7,10 2. Maintain probe and retry
Slope too close to Standard !	1. pH Slope value within 2 pH units (120 mV) of Standard value 2. Probe efficiency is too small	1. Use pH values with a greater difference in reading. 4,7,10 2. Clean probe and retry
SETUP READ ERROR Press Any Key	Memory fault occurred	Press any key to reload presets, then reprogram setpoints

4. Menu Functions - ORP

VIEW Menu: is displayed during standard operation.

- Press UP or DOWN buttons to view process parameters.
- Press UP and DOWN buttons at the same time, to exit any other display and return to VIEW menu.
- Display will return to VIEW menu in 10 minutes unless a key is pressed.

CALIBRATE Menu: contains display setup and output parameters. A security code feature prevents unauthorized tampering. To access CALIBRATE menu:

- Press ENTER button for 2 seconds to display:
- Press UP, UP, UP, DOWN buttons in sequence to display:

CALIBRATE: ----
Enter Key Code

CALIBRATE: KXXX
Enter Key Code

OPTIONS Menu: contains setup and display features for minor display or output adjustments. To access OPTIONS menu:

- Press ENTER button for 5 seconds to display:
- Press UP, UP, UP, DOWN buttons in sequence to display:

OPTIONS: ---
Enter Key Code

OPTIONS: KXXX
Enter Key Code

Menu Tips

- Right button scrolls to right, from top to bottom row, and allows editing when ">" symbol is shown.
- In CALIBRATE or OPTIONS menus, the transmitter will continue to measure and control outputs. When > is pressed, the input value is held at the last measured process value.
- When sensor is not connected, unit will display CHECK SENSOR and any output controlled by sensor will be at 3.6 mA or OFF.

Example

To change date, first enter CALIBRATE menu (Press ENTER button for 2 seconds; Press UP, UP, UP, DOWN buttons in sequence) Once in CALIBRATE menu, press UP button 1 time.

1. Display shows right arrow

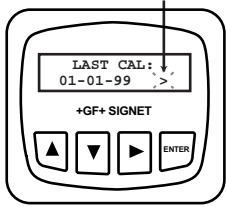

2. Press RIGHT button to display "01" blinking

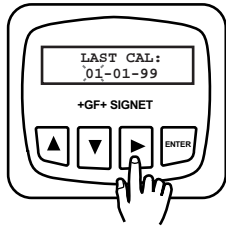

3. Press buttons to scroll through numbers.

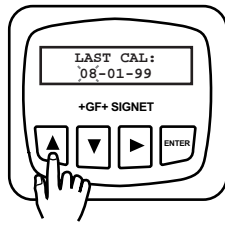

4. Press ENTER button to save

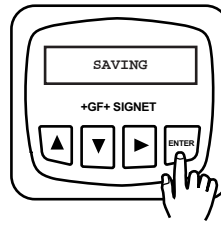

5. Display now reads new date

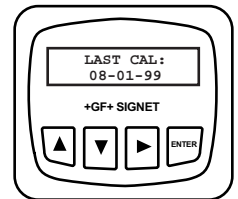

Menu Functions - ORP

View Menu	Range
ORP: mV	-1000 to +2000 mV
Input: mV	+2000 mV
Loop1 Output: mA	4-20 mA
Loop2 Output: mA	4-20 mA
Last Cal: Date	00-00-00 to 39-39-99
Easy Cal: >	87 and 264 mV solutions

Settings repeat for Output2

Calibrate Menu	Range	Preset
Set: Standard >	-1000 to +2000 mV	N/A
Set: Slope >	-1000 to +2000 mV	N/A
Loop1 Range: mV -1000->+1000 (4mA) (20 mA)	-1000 to +2000 mV	-1000 to +1000 mV
Loop2 Range: mV -1000->+1000 (4mA) (20 mA)	-1000 to +2000 mV	-1000 to +1000 mV

Output1 Mode: Low >	Off Low Hi Pulse	Low (Output1) Hi (Output2)
---------------------	---------------------------	-------------------------------

Low or High selected

Output1 Setpnt: -500 mV >	-1000 to +2000 mV	-500 mV
Output1 Hys: 10 mV >	0 to 2000 mV	10 mV

Pulse selected

Output1 Range: mV -500->+500 (Start>Endpoint)	-1000 to +2000 mV	-500 to +500 mV
Output1 PlsRate: 120 pulses/min >	0-400 pulses/min	120 pulses/min

Last Cal: 01-01-99 >	00-00-00 to 39-39-99	01-01-99
----------------------	----------------------	----------

Options Menu	Range	Preset
Contrast: Level >	1-5	3
Averaging: Off >	Off Low (4secs) High(8secs)	Off
Output1 Active: Low >	Low High	Low
Output2 Active: Low >	Low High	Low
Loop1 Adjust: 4.00 mA >	3.8 to 5.0 mA	4.00 mA
Loop 1 Adjust: 20.00 mA >	19.0 to 21.0 mA	20.00 mA
Loop2 Adjust: 4.00 mA >	3.8 to 5.0 mA	4.00 mA
Loop 2 Adjust: 20.00 mA >	19.0 to 21.0 mA	20.00 mA
Test Loop1: >	4-20 mA	N/A
Test Loop2: >	4-20 mA	N/A
Test Output1: >	On or Off	N/A
Test Output2: >	On or Off	N/A





EASY CAL Procedure - ORP

This procedure simplifies system calibration using standard pH buffers. Use 4.0, 7.0 buffers **saturated with Quinhydrone (customer supplied)**. If standard pH buffers are not available, the system can be calibrated using the CALIBRATE menu STANDARD and SLOPE settings. Access CALIBRATE menu and set sensor temperature before performing EASY CAL for new electrode installations.

EASY CAL: ----
Enter Key Code

Press UP, UP, UP, DOWN buttons in sequence to enter menu,

*** will appear during code entry.

To Calibrate:	Response:	To Accept:
<p>Place Sensor in ORP Buffer #1</p>  <p>Place electrode tip in first pH buffer;</p> <p>pH 7.0 ≈ 87 mV pH 4.0 ≈ 246 mV</p>	<p>* ORP: + 84 mV Input: + 82 mV</p> <p>Allow for stabilization</p>  <p>30 seconds*</p>	<p>* ORP: + 84 mV Input: + 82 mV</p> <p>ENTER to accept</p> <p>* ORP: + 87 mV Input: + 82 mV</p>
<p>Place Sensor in ORP Buffer #2</p>  <p>Place electrode tip in second (different) pH buffer.</p> <p>pH 4.0 ≈ 246 mV pH 7.0 ≈ 87 mV</p>	<p>* ORP: +262 mV Input: +260 mV</p> <p>Allow for stabilization</p>  <p>30 seconds*</p>	<p>* ORP: +262 mV Input: +260 mV</p> <p>Press ENTER to accept second buffer calibration.</p> <p>* ORP: +264 mV Input: +260 mV</p>
<p>To exit menus and return to VIEW press UP and DOWN button at the same time</p> 	<p>Display returns to VIEW Menu in 10 minutes or when ENTER is pressed</p>	<p>Good Easy Cal Press <ENTER></p>

* For best results, gently stir the submerged electrode for approximately 5 seconds during the stabilization period.

Large temperature differences from process fluids to buffers may require longer stabilization time.

Technical notes:

The difference between the actual mV and value shown is a good indication of the condition of the electrode.

Differences in excess of 50 mV may indicate a need to service the electrode.

Troubleshooting - ORP

Display	Problem	Solution
Check Sensor ?	No sensor detected. You may enter the CALIBRATION and OPTIONS menu to program setpoint values even though Check Sensor? is displayed.	Connect sensor/preamplifier or proper resistance for unit of measure. 3KΩ for pH, 10KΩ for ORP.
Out of Range Check Sensor	Electrode not installed in preamplifier	1. Install sensor in preamp 2. Verify 3K Balco connection to transmitter (White/Green wires from preamplifier)
Out of Range Use Manual CAL	1. Did not use pH 4, 7 buffers saturated with quinhydrone 2. Excessive probe mV offset	1. Use pH 4, 7 buffers saturated with quinhydrone 2. Clean probe and retry EASY CAL. Use Manual calibration for Standard and Slope if mV offset exceeds 50 mV.
! Same Buffer EasyCal only)	Same buffer used for Standard and Slope.	Place probe in alternate buffer solution.
Display stuck at ORP: +2000 mV or ORP: -1000 mV	Excessive positive or negative mV input from preamplifier	1. Verify preamplifier wiring 2. Check preamplifier with 2719 preamplifier tester. 3. Disconnect preamp completely out of range. Check Sensor should appear
Standard too close to Slope !	1. ORP Standard value within 120 mV of Slope value 2. Probe efficiency is too small	1. Use ORP values with a difference in reading greater than 120 mV's. 2. Maintain probe and retry
Slope too close to Standard !	1. ORP Slope value within 120 mV of Standard value 2. Probe efficiency is too small	1. Use ORP values with a difference in reading greater than 120 mV's. 2. Maintain probe and retry
SETUP READ ERROR Press Any Key	Memory fault occurred	Press any key to reload presets, then reprogram setpoints

+GF+ SIGNET

Signet Scientific Company, 3401 Aerojet Avenue, El Monte, CA 91731-2882 U.S.A. • Tel. (626) 571-2770 • Fax (626) 573-2057
For Worldwide Sales and Service, visit our website: www.gfsignet.com • Or call (in the U.S.): (800) 854-4090

GEORGE FISCHER +GF+ Piping Systems
3-8750.090-3/(B-10/99) English
page 8 of 8

© Scientific Company 1999



Printed in U.S.A. on Recycled Paper
+GF+ SIGNET 8750-3 pH/ORP Transmitter Instructions