



3-8850.090-1



A-9/99 English



CAUTION!

- Remove power to unit before wiring input and output connections.
- Follow instructions carefully to avoid personal injury.

Contents

1. Installation
2. Specifications
3. Electrical Connections
4. Menu Functions



1. Installation

The transmitter is available in two versions: a panel mount version, and an integral version for installation near the sensor (universal assembly)

1.1 Panel Installation

The Panel Mounting kits are supplied with the hardware to install instrumentation into panels and maintain a NEMA 4X watertight seal.

1. Punch out panel and de-burr edges. Recommended clearance on all sides between instruments is 1 inch.
2. Place gasket on instrument, and install in panel.
3. Slide mounting bracket over back of instrument until quick-clips snap into latches on side of instrument.
4. Connect wires to terminals.
5. To remove, secure instrument temporarily with tape from front or grip from rear of instrument. DO NOT RELEASE. Press quick-clips outward and remove.

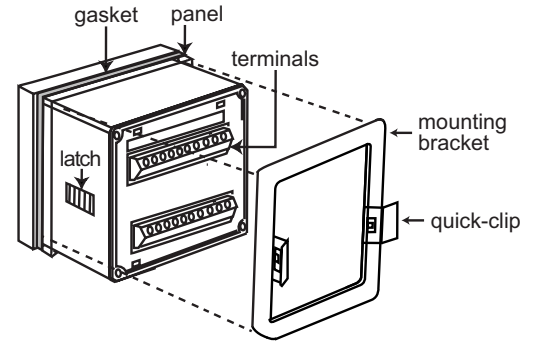

1.2 Universal Assembly (3-8050)

1. Install transmitter base
2. Connect wires to transmitter.
3. Close unit and secure with push and twist lock. Seal cable entry.

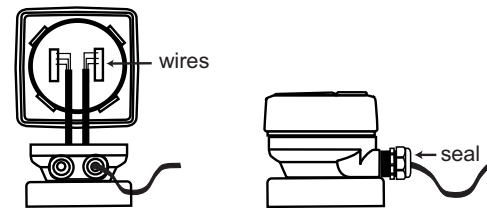

2. Specifications

General

Compatible electrodes: +GF+ SIGNET 3-28XX-1 Standard and Certified Series Conductivity/Resistivity Electrodes

Accuracy: $\pm 2\%$ of reading

Enclosure:

- Rating: NEMA 4X/IP65 front
- Case: PBT
- Window: Polyurethane coated polycarbonate
- Keypad: Sealed 4-key silicone rubber
- Weight: Approx. 325g (12 oz.)

Display:

- Alphanumeric 2 x 16 LCD
- Contrast: User selected, 5 levels
- Update rate: 1 second

Environmental

Operating temperature: -10 to 70°C (14 to 158°F)

Storage temperature: -15 to 80°C (5 to 176°F)

Relative humidity: 0 to 95%, non-condensing

Standards and Approvals

- CSA, CE, UL listed
- Manufactured under ISO 9001

Electrical

Sensor input range:

- Conductance: 0.055 to 400,000 μS
- Resistivity: 10 $\text{K}\Omega$ to 18.26 $\text{M}\Omega$
- TDS: 0.023 to 200,000 ppm
- Temperature: PT 1000, -25 to 120°C (-13 to 248°F)

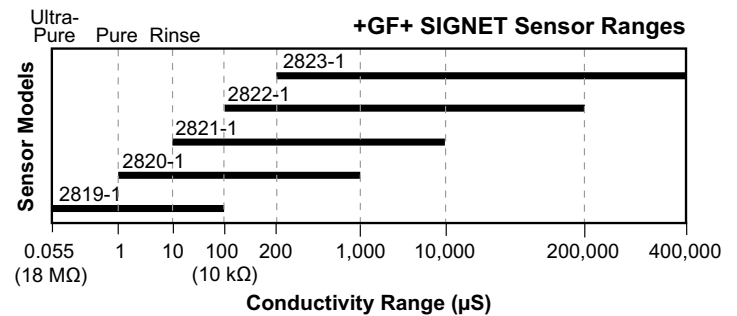

Current output:

- 4 to 20 mA, isolated, fully adjustable and reversible
- Power: 12 to 24 VDC $\pm 5\%$, regulated
- Max loop impedance: 50 Ω max. @ 12 V, 325 Ω max. @ 18 V, 600 Ω max. @ 24 V

- Update rate: 0.5 seconds
- Accuracy: ± 0.03 mA @ 25°C , 24 V

Open-collector output: Hi, Lo, Pulse Programmable

- Open-collector, isolated, 50 mA sink or source, 30 VDC max. pull-up voltage

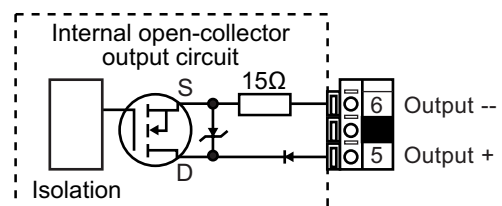

Field Mount

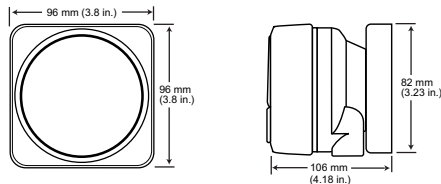

Panel Mount

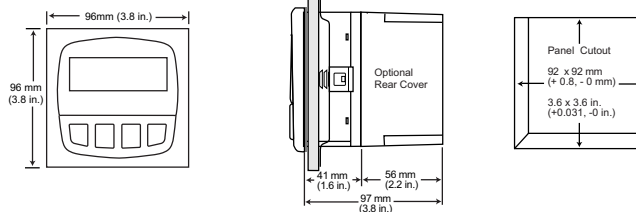

3. Electrical Connections



Caution: Failure to fully open terminal jaws before removing wire may permanently damage instrument.

Wiring Procedure

1. Remove 0.5 - 0.625 in. (13-16 mm) of insulation from wire end.
2. Press the orange terminal lever downward with a small screwdriver to open terminal jaws.
3. Insert exposed (non-insulated) wire end in terminal hole until it bottoms out.
4. Release orange terminal lever to secure wire in place. Gently pull on each wire to ensure a good connection.

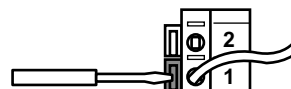

Wiring Removal Procedure

1. Press the orange terminal lever downward with a small screwdriver to open terminal jaws.
2. When fully open, remove wire from terminal.

Terminals

Terminals	Description
1 AUX Power +	12-24 VDC
2 AUX Power -	

System Power/Loop

3. System Power/Loop + 12-24 VDC $\pm 5\%$, system power and current loop connections.
4. System Power/Loop - Max. loop impedance: 50 Ω max @12 V, 600 Ω max. @ 24 V.

Open Collector Output

5. Output +
 6. Output -
- Open-collector transistor output programmable as:
- High/Low alarm with adjustable hysteresis
 - Proportional pulse output
 - Disable (Off) selection

Sensor Input

7. Red (Signal IN)
8. White (Temp IN)
9. Black (Iso GND)
10. Shield (Sensor Gnd)

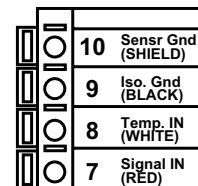
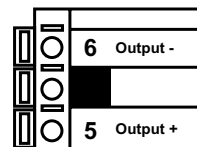
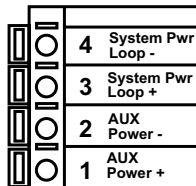

Wiring Tips:

- Do not route sensor cable in conduit containing AC power wiring - electrical noise may interfere with sensor signal.
- Routing sensor cabling in grounded metal conduit may prevent moisture damage, electrical noise, and mechanical damage.
- Seal cable entry points to prevent moisture damage.
- When placing two wire ends into a single terminal, solder or crimp ends together.

3.1 System Power/Loop Connections

Stand-alone application, no current loop used

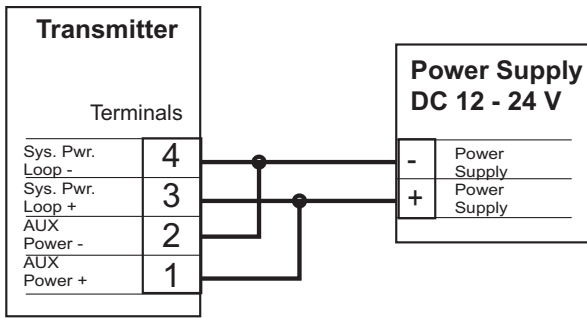

Connection to a PLC with built-in power supply

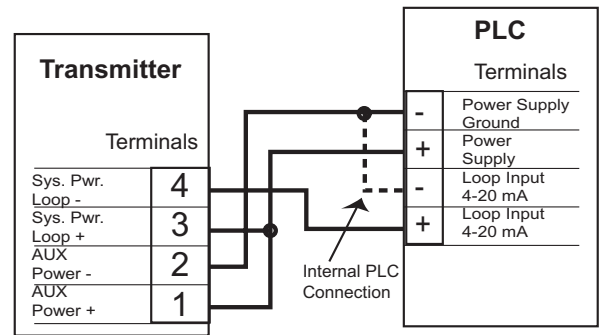

Connection to a PLC/Recorder, separate supply

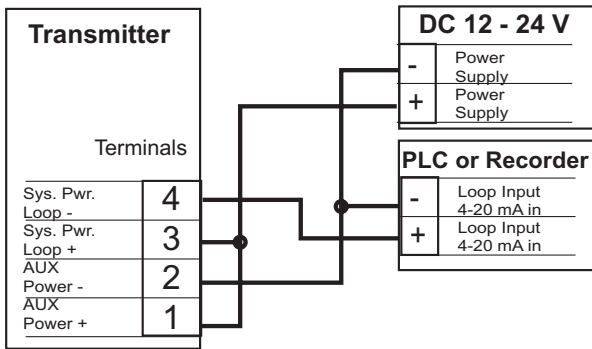

Example: Two transmitters connected to PLC/Recorder with separate power supply

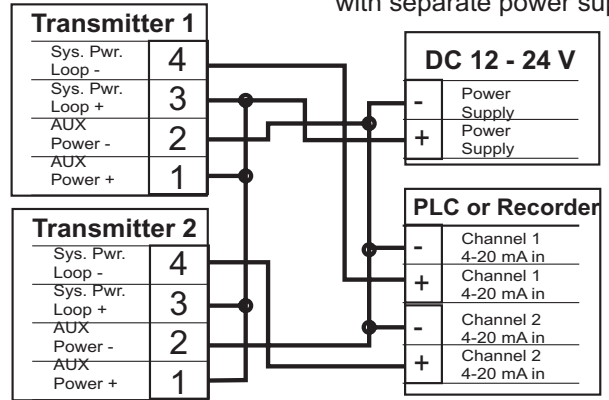

3.2 Sensor Input Connections

Wiring Tip:

Do not route sensor cable in any conduit containing AC power wiring - electrical noise may interfere with the signal.

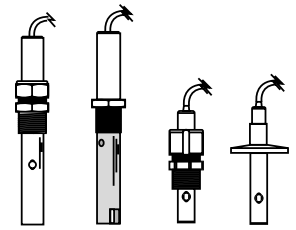
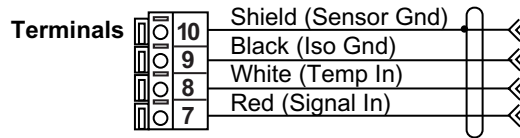

+GF+ SIGNET 28XX-1 Standard and Certified Cells

3.3 Open Collector Functions

- **Low:** Output triggers when process variable is less than setpoint.
- **High:** Output triggers when process variable is higher than setpoint.

Example: In Low Alarm Mode Operation, the output becomes active when the process drops below the setpoint, and becomes inactive when the process rises above the setpoint plus hysteresis. The opposite is true for High Alarm Mode.

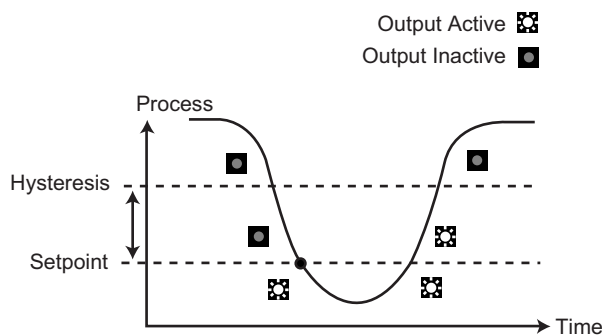

- **Off:** Disables output pulse.
- **Proportional Pulse Mode Operation**
The output emits a 100 mS pulse (simulated contact closure) at rate defined by the Output, Pulse Range, and the process condition (0 to 400 pulses/minute, as programmed)
Example: As the process falls below 10 the output will start pulsing in relation to the process value, the max pulse endpoint and the programmed pulses/min. Pulse rate will increase as the process approaches the programmed endpoint.

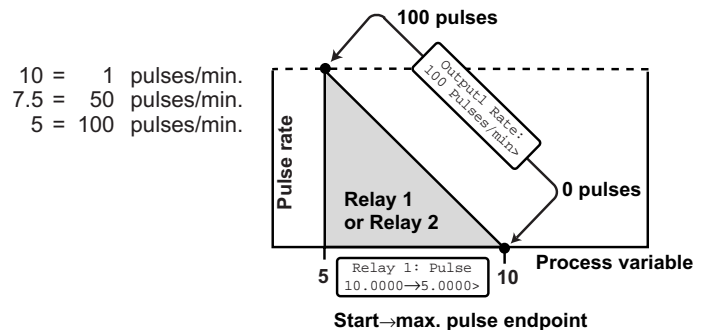

4. Menu Functions

VIEW Menu: is displayed during standard operation.

- Press UP or DOWN buttons to view process parameters.
- Press UP and DOWN buttons at the same time, to exit any other display and return to VIEW menu.
- Display will return to VIEW menu in 10 minutes unless a key is pressed.

CALIBRATE Menu: contains display setup and output parameters. A security code feature prevents unauthorized tampering. To access CALIBRATE menu:

- Press ENTER button for 2 seconds to display:
- Press UP, UP, UP, DOWN buttons in sequence to display:

CALIBRATE: ----
Enter Key Code

CALIBRATE: XXXX
Enter Key Code

OPTIONS Menu: contains setup and display features for minor display or output adjustments. To access OPTIONS menu:

- Press ENTER button for 5 seconds to display:
- Press UP, UP, UP, DOWN buttons in sequence to display:

OPTIONS: ----
Enter Key Code

OPTIONS: XXXX
Enter Key Code

Menu Tips

- Right button scrolls to right, from top to bottom row, and allows editing when ">" symbol is shown.
- In CALIBRATE or OPTIONS menus, the transmitter will continue to measure and control outputs. When > is pressed, the input value is held at the last measured process value.
- When sensor is not connected, unit will display CHECK SENSOR and any output controlled by sensor will be at 3.6 mA or OFF.

Example

To change date, first enter CALIBRATE menu (Press ENTER button for 2 seconds; Press UP, UP, UP, DOWN buttons in sequence) Once in CALIBRATE menu, press UP button 1 time.

1. Display shows right arrow

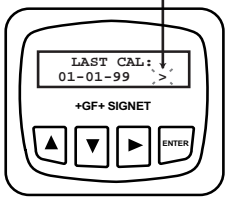

2. Press RIGHT button to display "01" blinking

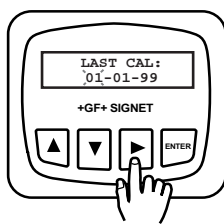

3. Press buttons to scroll through numbers.

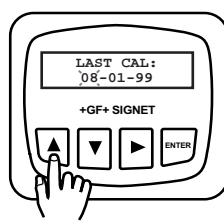

4. Press ENTER button to save

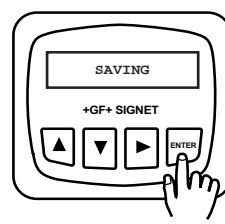

5. Display now reads new date

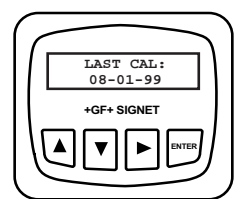

Menu Functions

View Menu	Range
Cond. Unit Temperature	sensor based
Loop Output: mA	4 - 20 mA
Last Cal: Date	00-00-00 to 39-39-99

Calibrate Menu	Range	Preset
Cell Constant: Standard >	Standard Custom	Standard
Cell: Standard 1 >	0.01 0.1 1 10 20	1
Cell: Custom 1.0000 >	0.0000 to 999999	1.0000
Cond Units: uS >	uS mS PPM* mSd mSd	uS/cm

If PPM selected

PPM Factor: 2.00 >	0.00 to 3.00	2.00 *(TDS ppmf)
--------------------	--------------	---------------------

Set Temperature: >	± 20 °C	N/A
Set: Conductivity >	0.0000 to 999999	N/A
Loop Source: Cond >	Cond Temp	Cond
Loop Range: uS 0.00 -> 100.00 > (4mA) (20 mA)	0.0000 to 999999	0.00 to 100 uS/cm
Output Source: Cond >	Cond Temp.	Cond
Output Mode: Low >	Off Low Hi Pulse	Low

Low or High Selected

Output Setpnt: 10 uS >	0.0000 to 999999	10 uS
Output Hys: uS 0.50 >	0.0000 to 999999	0.5 uS

Pulse Selected

Output Rng: uS 10.00 > 40.00 > (Start>Endpoint)	0.0000 to 999999	10-40 uS
Output PlsRate: 120 pulses/min >	0-400 pulses/min	120.00 pulses/min

Last Cal: 01-01-99 >	00-00-00 to 39-39-99	01-01-99
----------------------	----------------------	----------

Options Menu	Range	Preset
Contrast: Level >	1-5	3
Cond Decimal **** *	***** to *****	*****
Averaging: Off >	Off Low (4secs) High(8secs)	Off
Loop Adjust: 4.00 mA >	3.8 to 5.0 mA	4.00 mA
Loop Adjust: 20.00 mA >	19.0 to 21.0 mA	20.00 mA
Temp Display: °C >	°C °F	°C
Temperature Comp %: 2.00 >	0.00 to 10.00%	2.00%
Output Active: Low >	Low High	Low
Test Loop: >	4-20 mA	N/A
Test Output: >	On or Off	N/A

Calibration Procedure

1. Requirements

Electronic calibration is performed to exacting standards by +GF+ SIGNET. System calibration will reduce errors which may be caused by sensor wire lengths longer than the standard 15 ft. length. Wire lengths of 100 feet are acceptable; cable shield must be maintained through cable splice. Calibration may be done by known solution value (A), or by resistance simulation (B).

A) Calibration with NIST Traceable Solutions:

When using NIST traceable standards, ensure the sensor and test solution are at the solution temperature specified on the test solution label. Prevent contamination of the calibration solution. Thoroughly rinse the sensor in a small amount of test solution before placing in any test solution for calibration purposes.

B) Optional Verification with Precision Resistors:

The use of precision resistors ($\pm 0.1\%$) connected to the rear "Temp In", "Signal IN", and "Iso Gnd" terminals in place of the +GF+ SIGNET sensor, yields quick and accurate electronic instrument calibration. Calibration is completed as follows:

- 1) Select a standard cell constant based on desired range of operation.
- 2) Place a 1096 Ω (25°C) resistor between "Temp IN" and "Iso. Gnd" terminals as shown.
Note: Temperature simulation errors can adversely effect calibration: $3.85 \Omega = 1^\circ\text{C}$.
- 3) Calculate the required simulation resistor that represents a value within the selected cell range. The formula for determining the required simulation resistance is:

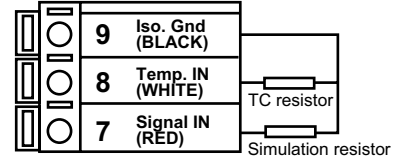

$$\text{Resistance} = \frac{\text{Sensor Cell}}{\text{Desired conductivity (Siemens*)}} : \text{e.g.} \frac{0.1 \text{ Cell}}{0.000020 \text{ (Siemens*)}} = 5,000 \Omega \text{ or } 5 \text{ K}\Omega$$

$$\text{Conductivity} = \frac{\text{Sensor cell}}{\text{Simulation resistance } (\Omega)} : \text{e.g.} \frac{0.1 \text{ Cell}}{100,000 (\Omega)} = 0.000001 \text{ Siemens*} \text{ or } 1\mu\text{S/cm}$$

(*Conversion: $1 \mu\text{S} = 1 \times 10^{-6}$ Siemens or 0.000001 Siemens)

- 4) Place the calculated simulation resistance between the "Signal IN" and "Iso Gnd" terminals as shown.
- 5) Set temperature and set conductivity. (Optional: enter zero to reset factory calibration (zero must be re-entered if currently displayed to reset factory calibration.)

2. Temperature Coefficient

Conductivity measurement is highly dependent on temperature. Temperature dependence is expressed as the relative change per $^\circ\text{C}$, commonly known as percent/ $^\circ\text{C}$ change from 25°C , or slope of the solution.

Slopes can vary significantly depending on process solution type. The factory default temperature compensation factor is $2.00\%/^\circ\text{C}$. Process solutions may require adjustment for maximum accuracy. To determine the optimum temperature compensation factor for a process:

1. Disable the 8850 temperature compensation % factor by entering 0.00
2. Heat the sample solution close to the maximum process temperature. Place sensor in the sample solution allowing several minutes for stabilization. Access the VIEW menu and record the displayed temperature and conductivity values in the spaces provided:

Displayed temperature: $T1 = \underline{\hspace{2cm}}^\circ\text{C}$
 Displayed conductivity: $C1 = \underline{\hspace{2cm}}^\circ\text{C}$

(Do not use this procedure for solutions from $0.055 \mu\text{S}$ to $0.1 \mu\text{S}$ ($10 \text{ M}\Omega$ to $18 \text{ M}\Omega$). An internal pure water curve is used for these ranges. The factory default setting of $2.00\%/^\circ\text{C}$ should be used.)

3. Cool the sample solution close to the minimum process temperature. Place sensor in the sample solution allowing several minutes for stabilization. Record displayed temperature and conductivity values in the spaces provided:

Displayed temperature: $T2 = \underline{\hspace{2cm}}^\circ\text{C}$
 Displayed conductivity: $C2 = \underline{\hspace{2cm}}^\circ\text{C}$

(A 10% change in conductivity between steps 2 and 3 is recommended.)

4. Substitute recorded readings (steps 2 and 3) into the following formula:

$$\text{TC Slope} = \frac{100 \times (C1 - C2)}{(C2 \times (T1 - 25)) - (C1 \times (T2 - 25))}$$

Example: A sample solution has a conductivity of $205 \mu\text{S}$ @ 48°C . After cooling the solution, the conductivity was measured at $150 \mu\text{S}$ @ 23°C . ($C1 = 205$, $T1 = 48$, $C2 = 150$, $T2 = 23$)
 The TC is calculated as follows:

$$\text{TC Slope} = \frac{100 \times (205 - 150)}{(150 \times (48 - 25)) - (205 \times (23 - 25))} = \frac{5500}{3860} = 1.42\%/^\circ\text{C}$$

3. Parts Per Million (PPM) Factor

This feature is only applicable when PPM display units are selected. The programmable PPM Factor is adjustable from 0.01 to 9.99 (factory default = 2.00). Determine the best PPM Factor for a process solution by calculating the solution's conductivity (µS) and the percent of total dissolved solids (PPM).

$$\text{PPM Factor} = \frac{\text{Solution conductivity } (\mu\text{S})}{\text{Total dissolved solids (PPM)}}$$

$$\text{TDS (PPM)} = \frac{\text{Solution conductivity } (\mu\text{S})}{\text{PPM Factor}}$$

Example:

- Solution conductivity = 400 µS
- TDS = 200 PPM (mg/L)
- PPM Factor = $\frac{400 \mu\text{S}}{200 \text{ PPM}} = 2.00$

Troubleshooting

Display	Problem	Solution
+ - - - - - - - - -	Over or under range.	Verify
Check Sensor ?	No sensor detected. Note: You may enter the CALIBRATION and OPTIONS menu to program setpoint values even though Check Sensor ? is displayed.	Connect sensor
Value Must be less than 18.21	Applies to Mohm display only. Setpoint value entered is not achievable	1. Reduce setpoint value 2. Set Temp Coefficient to 0.00
Value must be 0.0549 or more	Applies to uS/cm display only. Setpoint value entered is not achievable	1. Increase setpoint value 2. Set Temp Coefficient to 0.00
Value must be 400 or less	Setpoint value greater than 400.	Use a pulse rate value less than 400
SETUP READ ERROR Press Any Key	Memory fault occurred.	Press any key to reload presets, then reprogram setpoints.

+GF+ SIGNET

Signet Scientific Company, 3401 Aerojet Avenue, El Monte, CA 91731-2882 U.S.A. • Tel. (626) 571-2770 • Fax (626) 573-2057
For Worldwide Sales and Service, visit our website: www.gfsignet.com • Or call (in the U.S.): (800) 854-4090

