

+GF+ SIGNET 9010 Intellek-Pro

Flow Controller



Instruction Manual

GEORGE FISCHER +GF+

Important safety information

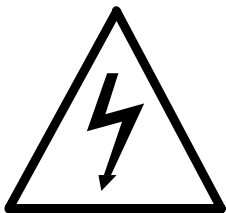

Danger: Avoid electric shock. Do not connect power when the instrument cover is partially or completely removed.

| Chapter | Page | Table of Contents |
|----------------------------------------|-------------|--------------------------|
| 1 Introduction | 1 | |
| 1.1 Introduction | 1 | |
| 1.2 Front Panel Description | 2 | |
| 1.3 Rear Panel Description | 3 | |
| | | |
| 2 Installation and Operation | 4 | |
| 2.1 Mounting Instructions | 4 | |
| 2.2 Power Connections | 5 | |
| 2.3 Input Connections | 6 | |
| 2.4 Standard Output Connections | 7 | |
| 2.5 Relay Output Connections | 8 | |
| 2.6 Verifying Analog Outputs | 9 | |
| 2.7 Analog Output Connections | 10 | |
| | | |
| 3 System Configuration | 10 | |
| 3.1 Introduction | 10 | |
| 3.2 Calibration Menu, Frequency Inputs | 12 | |
| 3.3 Calibration Menu, Analog Inputs | 12 | |
| 3.4 2-Relay Operations | 15 | |
| 3.5 Calibration Menu, 2-Relay | 16 | |
| 3.6 Calibration Menu, Analog Outputs | 17 | |
| 3.7 View-Only Menus | 18 | |
| | | |
| 4 Technical Support | 19 | |
| 4.1 Accessing Internal Options | 19 | |
| 4.2 AC Power Configurations | 19 | |
| 4.3 Installing Input/Output Options | 20 | |
| 4.4 Option Cards and Accessories | 21 | |
| 4.5 Input Card Configuration | 22 | |
| 4.6 Output Card Configuration | 23 | |
| 4.7 Troubleshooting | 23 | |
| | | |
| Specifications | 24 | |
| Warranty Information | 26 | |

Unpacking and Inspection

Your flow controller package includes the following items:

- +GF+ SIGNET 9010 Intelek-Pro Flow Controller
- Two stainless steel mounting brackets
- Mounting Instructions w/self-adhesive template
- Panel gasket
- Instruction manual w/assorted engineering labels

Warranty Record

For your protection, record your unit's purchase information for future reference. The serial number decal is located on the instrument's rear panel.

Model: +GF+ SIGNET 9010 Intelek-Pro Flow Controller

Purchase Date: _____

Serial Number: _____

Purchased From: _____

Purchase Order Number: _____

Chapter 1

Introduction

1.1 Introduction

Your new +GF+ SIGNET 9010 Inteltek-Pro Flow Controller has been specifically designed for liquid flow rate measurement in process pipes. The controller's compact 1/4 DIN enclosure (front) is NEMA 4X/IP65 rated and ideal for installing into instrumentation panels with limited space.

Modular "plug-in" input/output option cards allow you to customize your flow controller to your flow system's requirements. The controller's unique "slide-out" chassis design makes option installation fast and simple. Smart self-configuring microprocessor based circuitry automatically inventories installed options during power-up, allowing you to upgrade your system in seconds without the need for additional equipment.

The unit's front panel features a highly visible 4.5- digit (seven segment) and 8-digit (alpha-numeric) liquid crystal display with adjustable contrast. Active flow rate, accumulation, and alarm relay information is quickly accessed at a glance. During calibration the user is prompted with clear step-by-step instructions on the unit's front panel display.

The +GF+ SIGNET 9010 Inteltek-Pro Flow Controller is fully compatible with all +GF+ Signet flow sensor products, yet also accepts other analog inputs, such as 4 to 20 mA or 0 to 5 VDC etc.





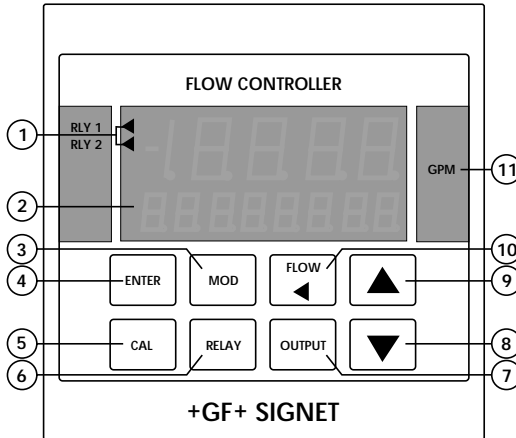



The technical data given in this publication is for general information purposes only. It implies no warranty of whatever kind.

1.2 Front Panel Description



Item 11:

Remove front bezel to change unit tags under clear overlay window. The unit tags are attached to the rear cover of the manual.

| Item | Function |
|-----------------------------------------------------------------------------------------|-----------------------------------------------------------------------------------------------------------------------------------------------------------------------------------------------|
| 1. Relay Annunciators: | Indicate activation status of optional output "alarm" relays 1 & 2 |
| 2. LCD Display: | Shows flow, calibration, accumulation, and relay activation status information |
| 3.  | A) Accesses one of three calibration menus: CAL, RELAY, OUT B) Enables a calibration parameter for modification C) Restores a calibration parameter to it's original value during calibration |
| 4.  | A) Stores a calibration value into memory after modification B) Used to display available input/output options during normal operation. |
| 5.  | A) Accesses the CAL "view-only" menu B) Used in conjunction with MOD key to access the main CAL menu |
| 6.  | A) Accesses the RELAY "view-only" menu B) Used in conjunction with MOD key to access the RELAY calibration menu |
| 7.  | A) Accesses the OUTPUT "view-only" menu B) Used in conjunction with MOD key to access the OUTPUT calibration menu |
| 8.  | Decreases the value of a selected calibration digit |
| 9.  | Increases the value of a selected calibration digit |
| 10.  | A) Returns the unit to normal operation mode B) Selects a digit for modification during calibration |
| 11. Unit Tags | Most engineering units and blanks available for custom applications (included). User selected and installed for specific applications. |

1.3 Rear Panel Description

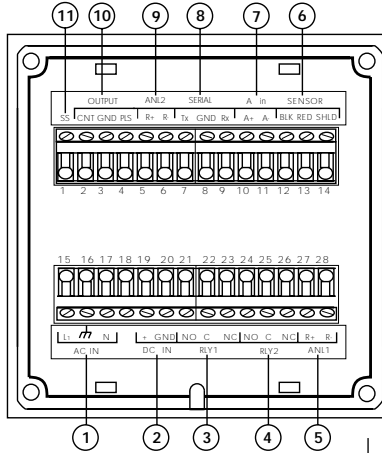

Note: Rear terminals accept 18 to 22 AWG wire

| Function | Item |
|-------------------------------------------------------------------------------------------------------------------------------------------|------------|
| 90 to 132 VAC or 180 to 264 VAC system power connection | 1. AC IN |
| 17 to 30 VDC system power connection | 2. DC IN |
| Alarm relay #1 (COM, NO, NC) contact set for external device control (optional) | 3. RLY 1 |
| Alarm relay #2 (COM, NO, NC) contact set for external device control (optional) | 4. RLY 2 |
| Analog output #1 from option socket #1 (optional) | 5. ANL1 |
| Flow sensor input connection (frequency) | 6. Sensor |
| Analog signal input connection (optional) | 7. A in |
| Serial outputs (future availability) | 8. Serial |
| Analog output #2 from option socket #2 (optional) | 9. ANL2 |
| CNT emits an open collector pulse output for each increment of totalizer. PLS emits a TTL frequency output in phase with the sensor input | 10. Output |
| Unused Terminal | 11. SS |

Chapter 2

Installation and Operation

2.1 Mounting Instructions

The +GF+ SIGNET Intelek-Pro Flow Controller's 1/4 DIN enclosure is specifically designed for panel mounting. Adjustable mounting brackets allow mounting in panels up to 1 in./25 mm thick. An adhesive template and instructions are included to insure proper installation.

For outdoor and/or stand alone installations the splash-proof NEMA 4X/IP65 back cover kit is recommended (ordered separately).

Figure 1

External dimensions

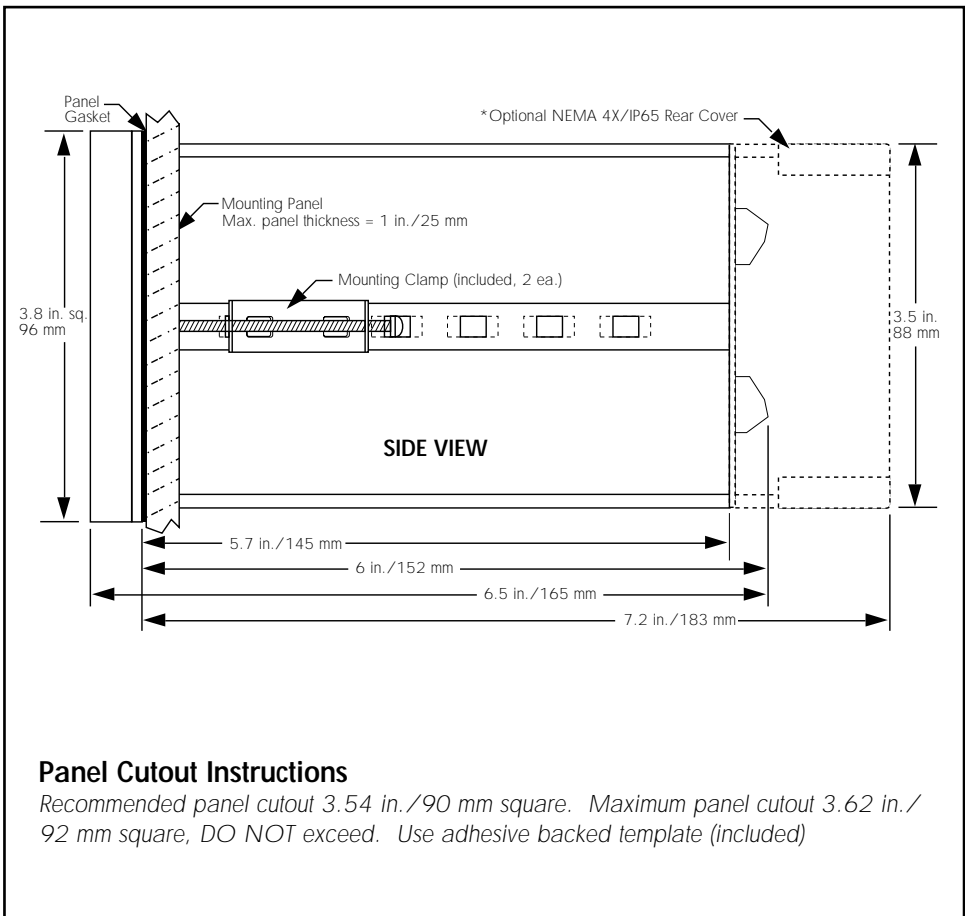

2.2 Power Connections

AC Power Connections

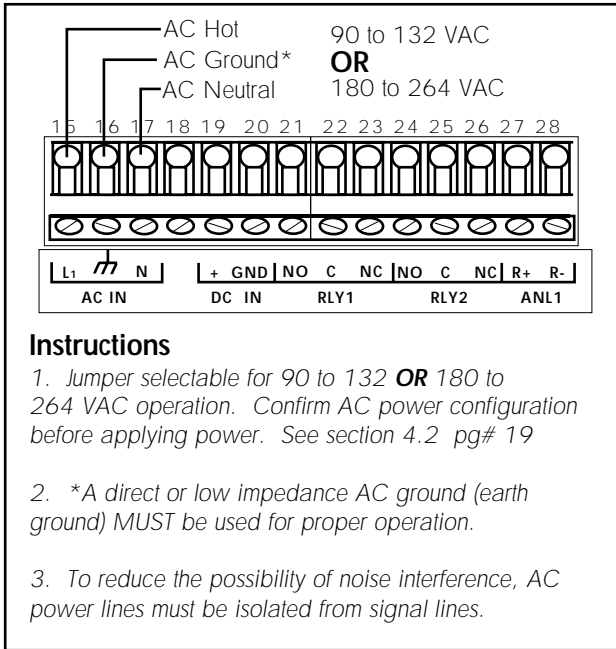
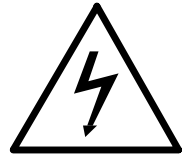

Figure 2
AC power wiring



Danger: Avoid electric shock. Do not connect power when the instrument cover is partially or completely removed.

DC power is recommended when ground fault interrupt devices (GFI's) are used.

DC Power Connections

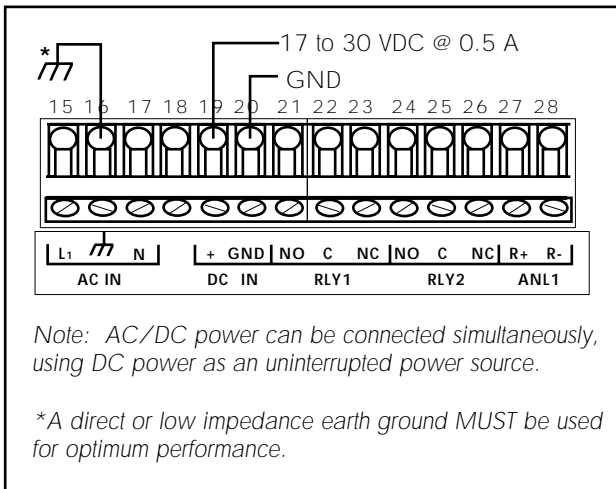

Figure 3
DC power wiring

2.3 Input Connections

Four input sources are accepted:

Note: See section 4.4 for a listing of available input cards.

A. Non-isolated Frequency Inputs

Frequency (non-iso) card: Accepts non-isolated, 0 to 10 kHz @ 0.2 Vp-p minimum sine or square wave signal inputs. This card requires dip switch configuration prior to operation.

B. Isolated Frequency Inputs

Frequency (iso) card: Accepts isolated, 0 to 10 kHz @ 0.5 Vp-p minimum sine or square wave signal inputs. No configuration required.

C. Analog Inputs

Two analog input cards are offered:

- Analog (iso) current, 4 to 20/0 to 20 mA
- Analog (iso) voltage, 0 to 5/0 to 10 VDC

Input ranges are software selectable, requiring no internal configuration.

Figure 4
Input Wiring

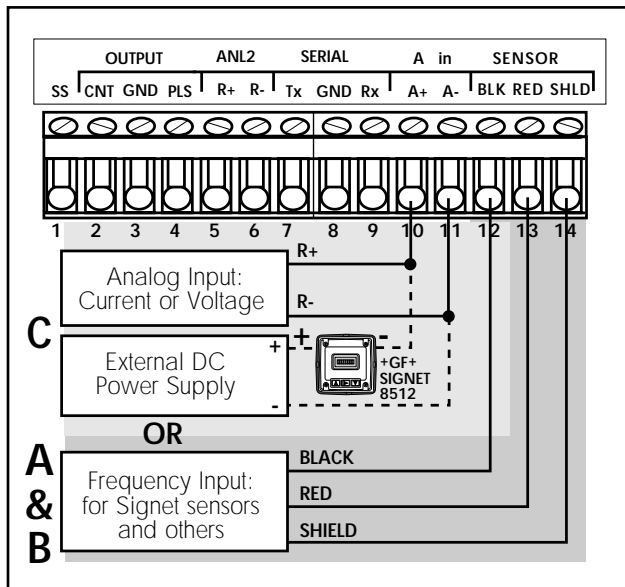

To reduce the possibility of noise interference, separate input lines from AC power lines.

2.4 Standard Output Connections

Standard Outputs

An open collector counter pulse output (CNT) and a sensor pulse output (PLS) are included with your unit.

The counter pulse output (synchronous w/totalizer) emits an open collector 150 ms pulse with a **maximum** current sinking capacity of 50 mA @ 30 VDC, and is ideal for driving an external counter or accumulator. **An external DC power supply and current limiting resistor are required for operation.**

The sensor pulse output (PLS) emits a standard TTL frequency output in phase with the sensor input and can be used to drive +GF+ SIGNET instruments (except +GF+ SIGNET 5090 and 5091) and other TTL compatible devices.

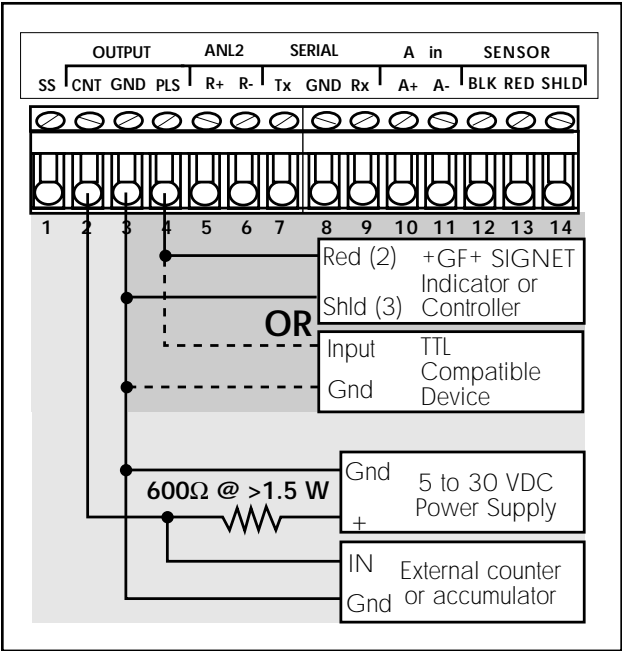

Figure 5
Sensor pulse output (PLS)/
counter output (CNT)
wiring

To reduce the possibility of noise interference, separate output lines from AC power lines.

2.5 Relay Output Connections

The 2-Relay option provides two relays for external device control. Each relay's contacts are rated for 5 A maximum. Both NO and NC contacts may be used individually or simultaneously as shown.

Figure 6
2-Relay wiring

Device A is powered during normal operation. Power is discontinued when relay is energized. Device B is not powered during normal operation. Power is applied after relay is energized.

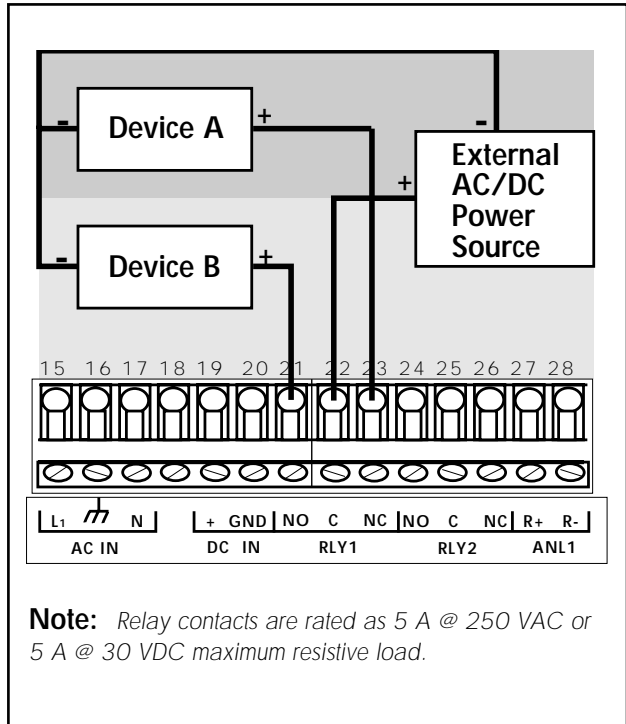

To reduce the possibility of noise interference, separate AC relay lines from input/output lines.

2.6 Verifying Analog Outputs

Installed analog output options can be configured to either of the unit's rear analog output terminals: ANL1 or ANL2. Configuration is determined by which sockets the options are installed. Options installed in option socket #1 are configured to the rear ANL1 terminals, options installed in socket #2 are configured to the rear ANL2 terminals (see section 4.3).

Prior to connection, determine which options are configured to terminals ANL1 and ANL2 as follows:

1. Apply power to unit.
2. Press: ; available input/output options are individually prompted on the display.
3. Record option configurations for ANL1 and ANL2 in the spaces provided. This information is necessary for wiring analog outputs in the next section.

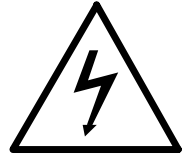

Danger: Avoid electric shock. Do not connect power when the instrument cover is partially or completely removed.

| |
|-----------------------------------|
| ANL1= (i.e. 4 to 20 mA) |
| ANL2= (i.e. N/A) |

Option Record

Note: The unit displays N/A for unavailable options.

2.7 Analog Output Connections

0 to 20/4 to 20 mA isolated or non-isolated output as well as 0 to 5/0 to 10 VDC isolated or non-isolated outputs are available. See section 4.4 for a list of available output cards.

Figure 7

Analog output wiring

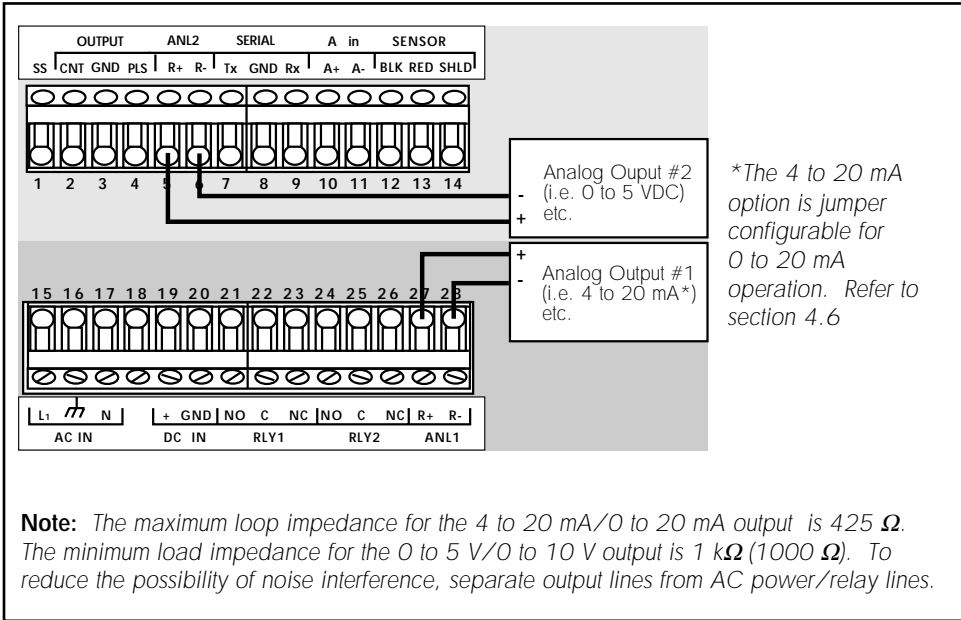

Chapter 3

System Configuration

3.1 Introduction



















All the functions which can be modified are contained in three menus:

The CAL (calibrate) menu contains those functions which pertain to the input signal and how it is interpreted by the instrument (i.e. K-factor, totalizer reset). The CAL menu also provides access to the security code and display contrast features.

The RELAY menu contains all the functions necessary to control any output relays, such as relay

setpoint, hysteresis etc.

The OUTPUT menu provides access to the functions which define and control all analog output signals, i.e. 4 to 20 mA, 0 to 5 VDC etc.

| CAL Menu |  | RELAY Menu |  | OUTPUT Menu |  |
|------------------------------------------------------------------------------------------------------------------------------------------------------------------------------------------------------------------------------------------------------------------------------------------------------------------------------------------------------------------------------------------------------|-----------------------------------------------------------------------------------|-----------------------------------------------------------------------------------------------------------------------------------------------------------------------------------------------------------------|-----------------------------------------------------------------------------------|----------------------------------------------------------------------------------------------------------------------------------------------------------------------------|-------------------------------------------------------------------------------------|
| (frequency) <ul style="list-style-type: none">• K-factor• K-factor decimal• Upper display timebase• Totalizer reset• Totalizer multiplier• Display averaging• Display decimal• Contrast adjust• Security code | | (LO/HI) <ul style="list-style-type: none">• Relay 1 LO/HI• Relay 1 setpoint• Relay 1 hysteresis• Relay 2 LO/HI• Relay 2 setpoint• Relay 2 hysteresis | | <ul style="list-style-type: none">• Minimum flow rate• Maximum flow rate• Low output adjust• High output adjust | |
| (Analog) <ul style="list-style-type: none">• Range selection• Minimum flow rate• Maximum flow rate• Totalizer reset• Totalizer multiplier• Display averaging• Display decimal• Contrast adjust | | (Pulse) <ul style="list-style-type: none">• Relay 1 Pulse• Relay 1 pulse flow unit setting• Relay 2 Pulse• Relay 2 pulse flow unit setting | | <p>Note: A security function is provided which allows the user to "lock out" the calibration menus, restricting access to calibration settings. See Figure 14 .</p> | |
| All menus are loop type menus which repeat until  is pressed. | | | | | |
| All menus operate using a standard sequence: | | | | | |
| 1. Press:  to enable calibration sequence. | | | | | |
| 2. Enter security code (when active) using:    ; press:  | | | | | |
| 3. Select menu:    ; press menu key to select item. | | | | | |
| 4. Press:  to enable modifying item. | | | | | |
| 5. Alter item using:    ; press:  to save entry. | | | | | |
| 6. Press corresponding menu key to advance to next menu item. | | | | | |
| 7. Repeat steps 4-6 for each menu item. Exit menu by pressing:  | | | | | |

3.2 Calibration Menu, Frequency Inputs

Legend

 = Press Keypad

 = Inteltek-Pro Display

 = Decision Block

 = Calibration procedure

K-factor Setting



"1" is displayed only when previously selected.

"1" flashes when deselected.

Table 1

Select upper display timebase:

- 1= flow displayed in seconds
- 2= flow displayed in minutes
- 3= flow displayed in hours
- 4= flow displayed in days

Note: Accumulator not affected by timebase.

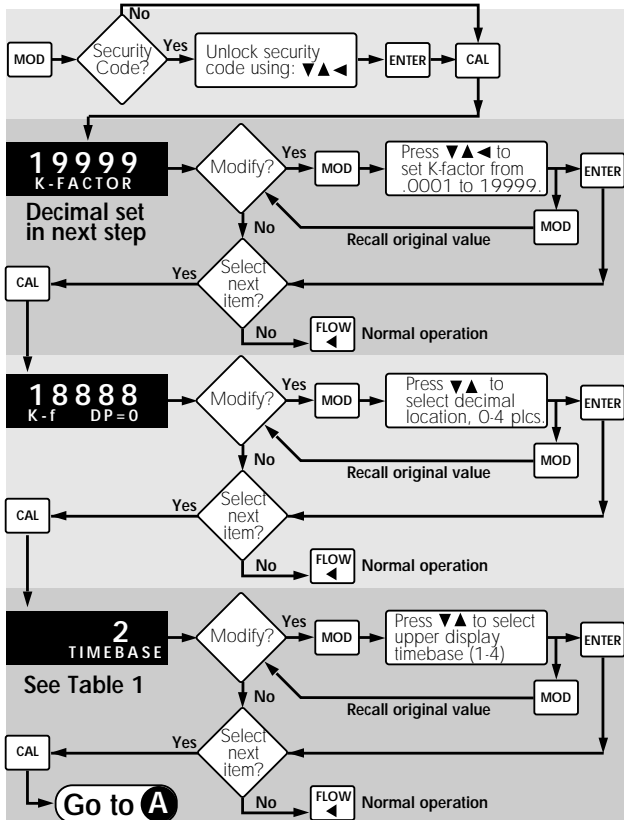

3.3 Calibration Menu, Analog Inputs

4 to 20 mA option illustrated

Note: The unit's software recognizes which input card/configuration is inserted, therefore displaying the corresponding calibration value.

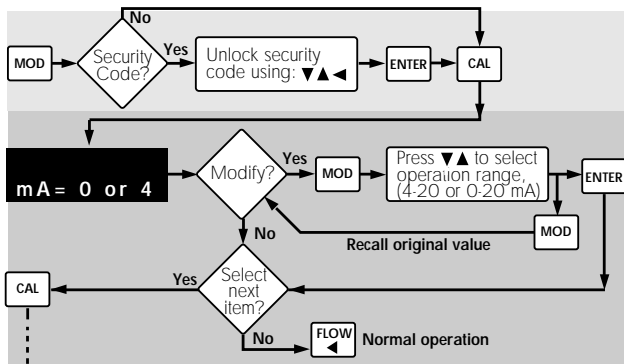

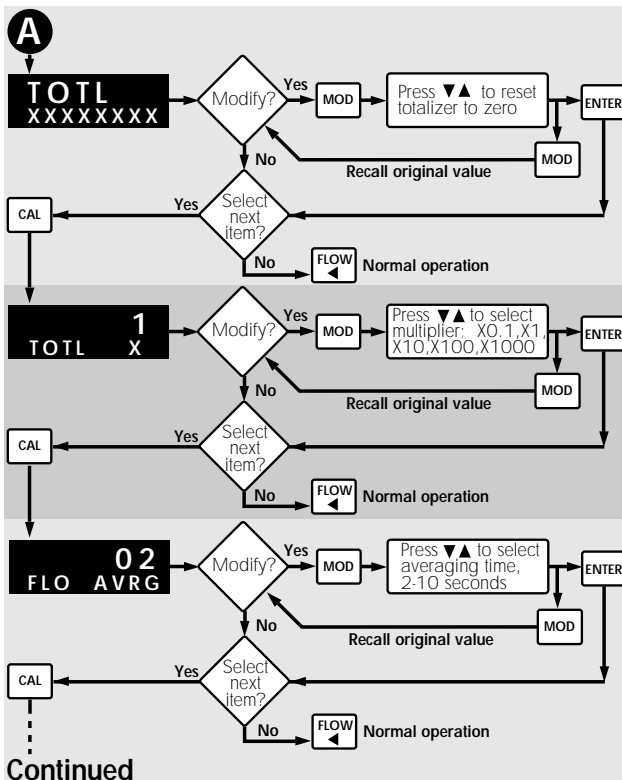
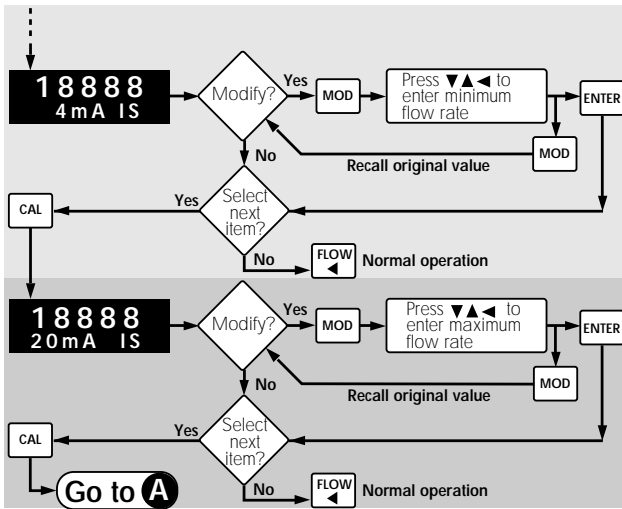

Exiting Menu

Menu will repeat until



is pressed.

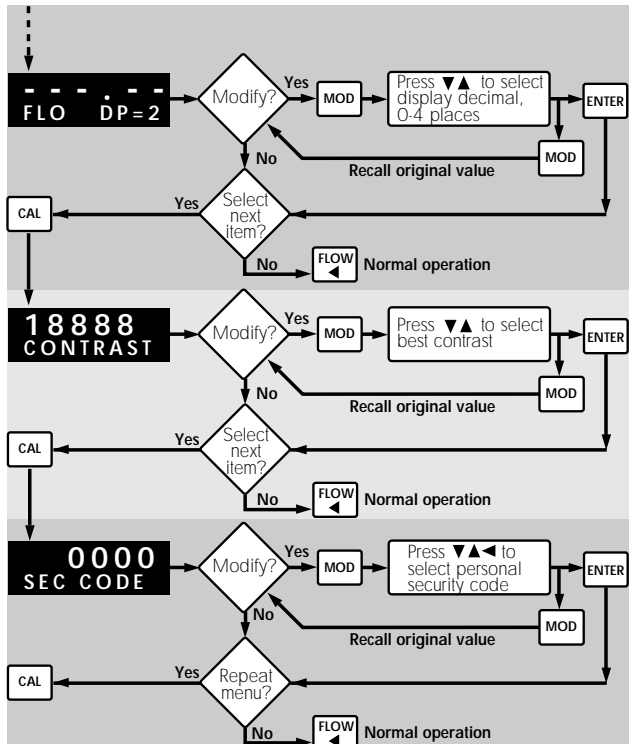

3.4 2-Relay Operations

The 2-Relay option allows you to configure individual setpoints, LO or HI operation, and hysteresis values for two independent on/off relays.

- Relay Setpoints: Setpoints represent the flow rate at which each relay is energized.
- Relay Hysteresis: Hysteresis values directly effect the LO and HI relay modes, specifying how far the flow will rise above (LO Relay Mode) or fall below (HI Relay Mode) each relay's setpoint prior to de-energizing the relay. The main purpose for hysteresis is to eliminate relay "chatter", caused by a flow hovering around a relay's setpoint. Hysteresis values are programmed in direct flow units and must be less than the corresponding relay setpoint. Hysteresis only applies when exiting an alarm condition.

- LO Relay Operation: In LO operation, the relay is energized when the flow drops below the set-point, and is de-energized when the flow rises above the setpoint plus hysteresis. See Figure 8.
- HI Relay Operation: In HI operation, the relay is energized when the flow rises above the setpoint and is de-energized when the flow falls below the setpoint plus hysteresis. See Figure 9.
- Pulse Relay Setting: Setting relay 1 or 2 to the Pulse operation mode means the relay will be cycled (energized) for a 150 ms period each time a user specified quantity is measured.

Figure 8
LO relay operation mode

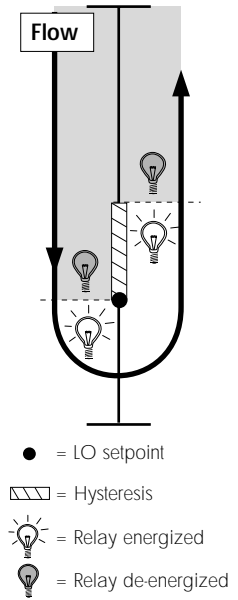
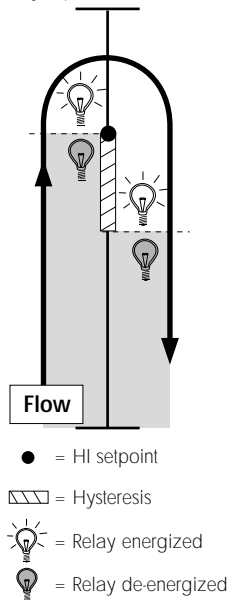
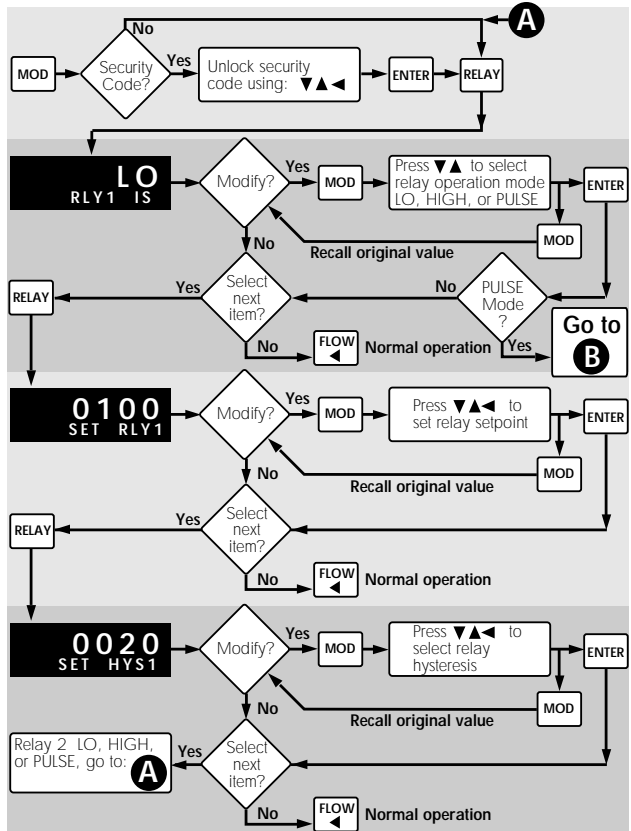

Figure 9
HI relay operation mode



3.5 Calibration Menu, 2-Relay



Note: Displayed decimal position set by CAL menu K-factor

Exiting Menu

Menu will repeat until  is pressed.

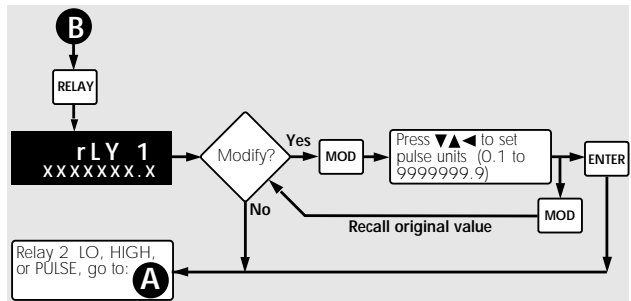

Note: Relay cannot exceed 4 pulses per second.

3.6 Calibration Menu, Analog Outputs

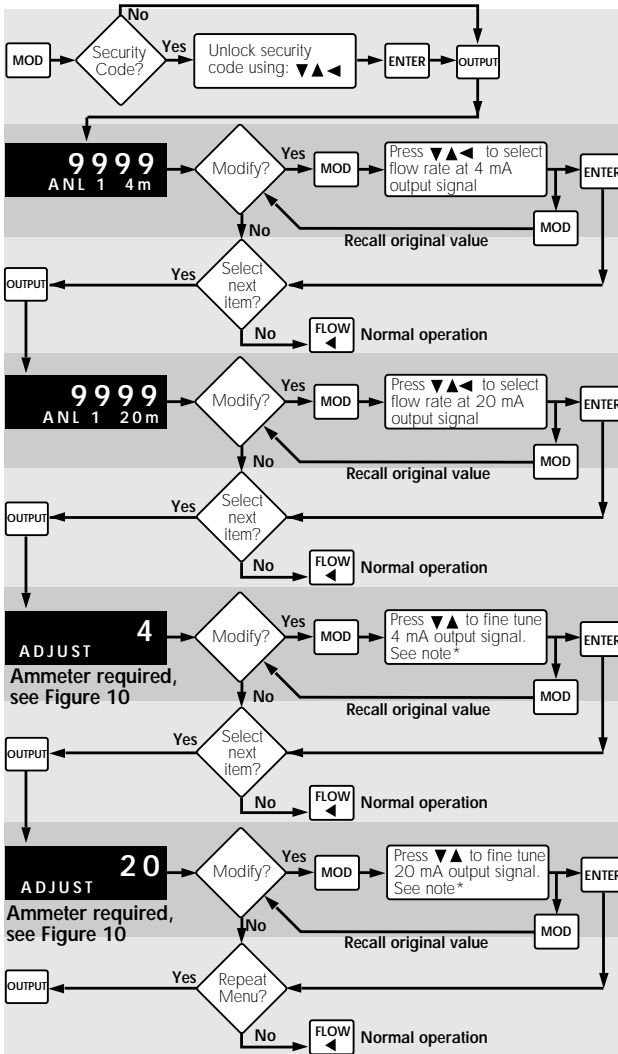

4 to 20/0 to 20 mA (iso/
non-iso) options illustrated

***Note:** Press:  to quickly access the minimum or maximum current output signal

Press:   to fine tune the current output signal

Figure 10
The min. and max. current adjustment steps require an external ammeter for monitoring the current output.

Exiting Menu

Menu will repeat until  is pressed.

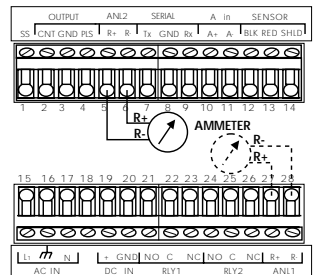

3.7 View-Only Menus

Note: The view-only menus are designed for viewing only and DO NOT permit access for calibration of any kind. Menus will vary depending upon installed options.

Three "view-only" menus (CAL, RELAY, and OUTPUT) are available during normal operation. Each view only menu provides the operator a means of browsing through calibration settings without disturbing system calibration and/or the flow process. When used in conjunction with the security feature, the view only menus allow an operator access to limited calibration information on the front display, excluding the ability to change system parameters without the supervisors approval and personal security code.

Access each of the three view only menus by pressing the corresponding menu key. After entering each of the three view only menus, each calibration parameter is sequentially displayed on the main and lower displays by successively pressing it's corresponding menu key as follows:

Exiting Menus: Exit view only menus at any time by

pressing: 

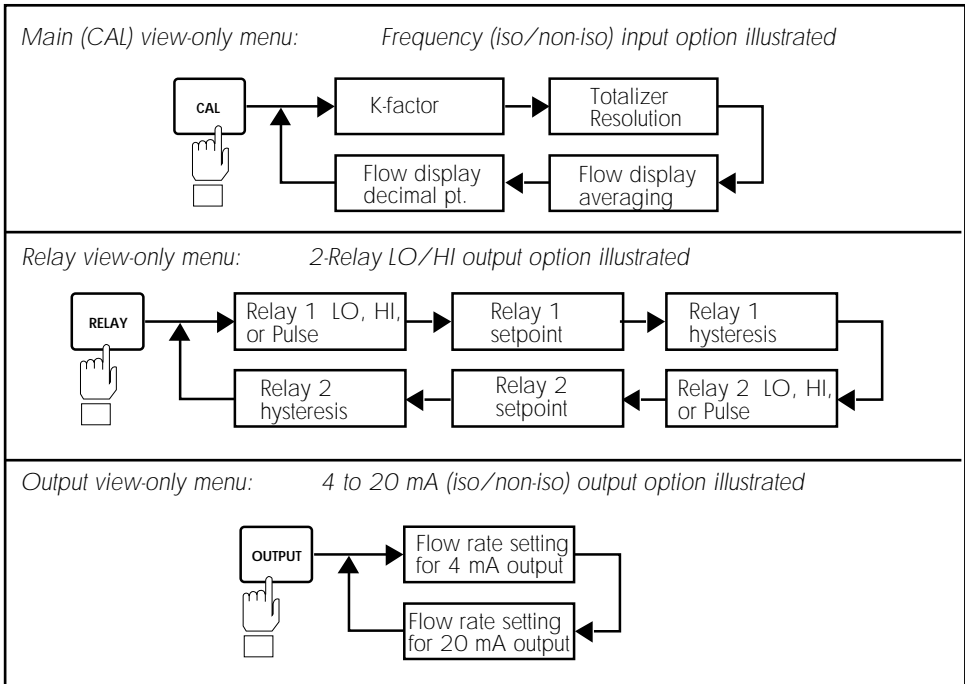

4.1 Accessing Internal Options

1. Remove bezel (1) by placing a coin in the notch (2), twist coin to remove the bezel from the instrument casing. See Figure 11
2. **Loosen the four front bracket screws (3)**, then loosen the center "jack-screw" (4). See Figure 12
3. Slide the electronics assembly (5) from the instrument casing. See Figure 13
4. Lift upper retainer with adhesive gasket to install/remove plug-in cards. Be sure plug-in cards are properly seated in slots before reassembling instrument. See Figure 13

Figure 11

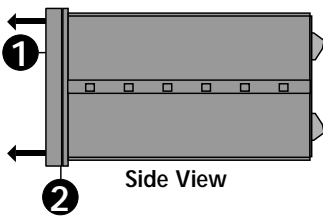

Figure 12

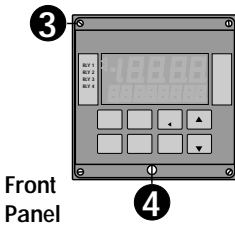
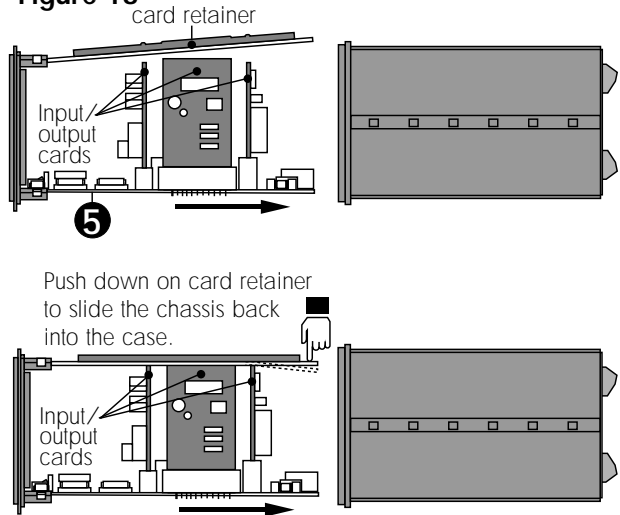

Figure 13



4.2 AC Power Configurations

Two AC power options are possible; 90 to 132 VAC, or 180 to 264 VAC. Each power option is selectable via internal jumpers on the main pc board. See Figure 14

Warning: Check AC configuration before applying power to unit.

Figure 14

Main PC Board

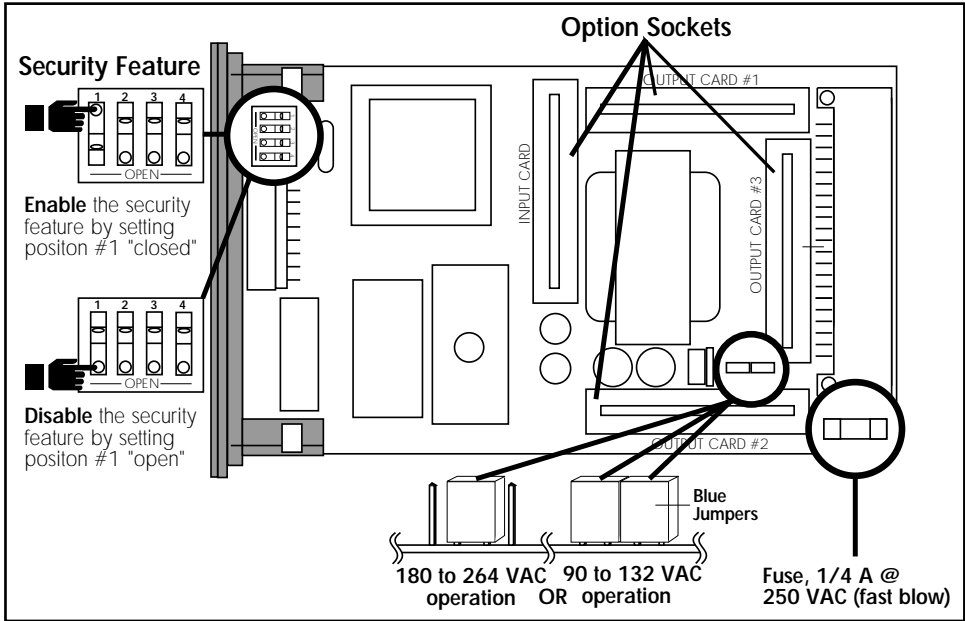

4.3 Installing Input/Output Options

Input/output option cards are "keyed" for proper insertion into four sockets. Sockets are located on the unit's main pc board and are clearly marked. See Figure 14 and table below:

| Socket Labeled | Compatible Options |
|----------------|----------------------------------------|
| Input Card | Dedicated for input cards |
| Output Card #1 | Accepts all analog output cards |
| Output Card #2 | Accepts all analog output cards |
| Output Card #3 | Dedicated for the 2-Relay output card. |

4.4 Option Cards and Accessories

| Part Number | Input Cards | Code |
|----------------------------------------------------------|----------------------------------------------------------------------|-------------|
| 3-9010.400-1 (requires configuration) See section 4.5 | Frequency Input (non-isolated) | 198 840 621 |
| 3-9010.400-2 (configuration not required) | Frequency Input (isolated) | 198 840 622 |
| 3-9010.400-3 | 4 to 20/0 to 20 mA input (isolated) | 198 840 623 |
| 3-9010.400-4 | 0 to 5/0 to 10 VDC input (isolated) | 198 840 624 |
| Part Number | Output Cards | Code |
| 3-9000.450-1 (requires configuration) See section 4.6 | 4 to 20/0 to 20 mA (non-isolated) | 198 840 631 |
| 3-9000.450-2 | 0 to 5 VDC (non-isolated) | 198 840 632 |
| 3-9000.450-3 | 0 to 10 VDC (non-isolated) | 198 840 633 |
| 3-9000.460-1 (requires configuration) See section 4.6 | 4 to 20/0 to 20 mA (isolated) | 198 840 634 |
| 3-9000.460-2 | 0 to 5 VDC (isolated) | 198 840 635 |
| 3-9000.460-3 | 0 to 10 VDC (isolated) | 198 840 636 |
| 3-9000.440-1 | 2-Relay card | 198 849 641 |
| Part Number | Accessories | Code |
| 3-5000.399 | +GF+ SIGNET mounting adapter plate | 198 840 224 |
| 3-5000.395 | NEMA 4X/IP65 back cover | 198 840 227 |
| 3-9010.650 | Assorted engineering labels | 198 840 205 |
| 3-9000.392 | Conduit connector kit for NEMA 4X back cover (includes 3 connectors) | 198 840 217 |

| Part Number | Spare Parts | Code |
|--------------|-----------------------------------|-------------|
| 3-9000.525-1 | Front bezel | 198 840 206 |
| 3-9000.575 | Panel mounting gasket | 198 840 207 |
| 3-9000.560 | Mounting Clamp | 198 840 216 |
| 2400-0404 | Front cover screws (4 each) | 198 840 209 |
| 3-9000.570 | Front cover gasket | 198 840 210 |
| 6400-0019 | Fuse, 1/4 A @ 250 VAC (fast blow) | 198 840 208 |

4.5 Input Card Configuration

The non-isolated Frequency Input Card (Part number 3-9010.400-1) requires dip switch configuration prior to operation. See Figure 15

Figure 15

Frequency (non-iso) input card dip switch settings

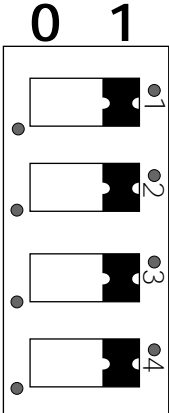
|  | +GF+ Signet Sensor 508 2502 | Dip switch settings | | Function 5 VDC power to sensor with pull down resistor No power to sensor with pulldown resistor No power to sensor with no pulldown resistor 5 VDC power to sensor with pull up resistor |
|-----------------------------------------------------------------------------------|------------------------------------------|---------------------|--|--------------------------------------------------------------------------------------------------------------------------------------------------------------------------------------------------------------------------|
| | | 1234 | | |
| | | 1011 | | |
| | 515 TTL inputs | 1111* | | |
| | 525 2515 2717 | 1110 | | |
| | 2000 2507 2536 2540 2550 | 1001 | | |

Frequency Input Card Dip Switch

*Dip switch factory configured for the +GF+ SIGNET 515 Rotor-X Paddlewheel Flow Sensor.

4.6 Output Card Configuration

Each 4 to 20/0 to 20 mA (iso or non-iso) output card contains jumper selections for its operation range.

- Placing the blue jumper in the "A" position configures the card for 4 to 20 mA operation.
- Placing the blue jumper in the "B" position configures the card for 0 to 20 mA operation.

Figure 16

4 to 20/0 to 20 mA output cards

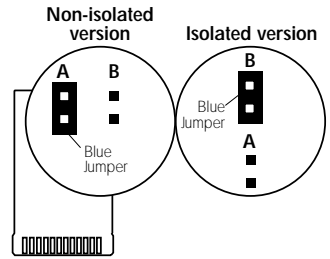

4.7 Troubleshooting

Error codes will be shown on the display after an abnormal occurrence, such as large amounts of electromagnetic interference or a large voltage transient on the AC power line occur.

Displayed error codes represent corrupted setup data in the internal memory which must be re-entered by the operator. See Figure 17

Figure 17

Displayed error codes

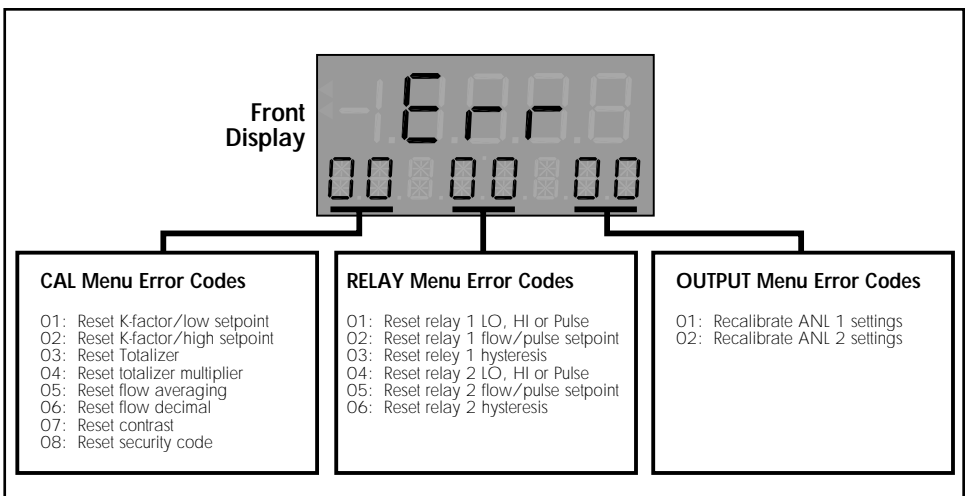

Specifications

Power Requirements

17 to 30 VDC @ 0.5 A max. and/or
90 to 132 VAC @ 50 to 60 Hz or
180 to 264 VAC @ 50 to 60 Hz

Operating Temperature

32 to 130 °F/0 to 55 °C

Relative Humidity

95% R.H. max., non-condensing

Enclosure

Materials: ABS plastic
Rating: NEMA 4X/IP65 front
NEMA 4X/IP65 rear cover (optional)
Dimensions: 3.5 X 3.5 X 6.0 in./
88 X 88 X 165 mm

Memory Backup

Non-volatile RAM

Liquid Crystal Display

4.5 digits, 0.5 in./12.7 mm height (upper)
8 digits, 0.3 in./7.6 mm height (lower)
2 alarm annunciators
Accuracy: 0-5 kHz input, 0.05% of reading

Display Averaging

Programmable from 2 to 10 seconds

Noise Immunity

Exceeds IEC 801-2, level 3, IEC 801-3, level 2

Input Signal

Frequency (iso or non-iso):

Frequency range: 0 to 10 kHz
K-factor range: .0001 to 19999.
Minimum signal amplitude:
Non-iso freq input: 0.2 Vp-p

(continued)

Isolated freq input: 0.5 Vp-p
Isolation: 500 VDC to earth ground

Flow Current and Voltage (iso):

Input range: 4 to 20 mA or 0 to 20 mA
0 to 5 VDC or 0 to 10 VDC
Isolation: 500 VDC isolation to earth ground

Output Signals

Sensor Pulse Output

TTL compatible synchronous with sensor input
Max. current sink: 20 mA
Max. current source: 10 mA

Counter Pulse Output

Open collector transistor synchronous with totalizer
Max. current sink: 50 mA @ 30 VDC max.

2-Relay

Outputs: Two SPDT contact outputs: 5 A @ 250
VAC or 30 VDC resistive load max. current

Analog 4 to 20 or 0 to 20 mA

Response time: 2.5 s max. for 100% change
Maximum loop resistance: 425 Ω
Isolation: 500 VDC to earth ground
Accuracy: $\pm 0.5\%$ of full scale

Analog 0 to 5 or 0 to 10 VDC

Response time: 2.5 s max. for 100% change
Maximum loop resistance: 1 k Ω (1000 Ω)
Isolation: 500 VDC to earth ground (optional)
Accuracy: $\pm 0.5\%$ of full scale

U.S. Warranty Information

Limited Two-Year Warranty

Signet Scientific Company warrants its instruments to be free from defects in material and workmanship under normal use for a period of two years from the date of purchase by the initial owner, or three years from date of manufacture, whichever comes first, as described in the following paragraphs.

This warranty does not cover defects caused by abuse or electrical damage. Signet Scientific Company will not cover under warranty any instruments damaged during shipment to the factory less case or if improperly packed. Repair attempts by anyone other than authorized service personnel will void the warranty. Proof of date of purchase will be required before warranty repairs can begin. Transducers and cables will not be covered after installation.

Parts which prove to be defective in the first year will be repaired or replaced free of charge including labor, shipped F.O.B. our factory or a designated service center (addresses furnished upon request).

Only non-moving parts, such as electrical components, which prove defective during the second year are warranted. Meter movements will not be covered. All units qualifying for warranty service after one year are subject to a service charge for replacement of non-moving parts.

Items returned for warranty repair must be shipped prepaid and insured. Warranty claims are processed on the condition that prompt notification of a defect is given to Signet Scientific Company within the warranty period.

Signet Scientific Company shall have the sole right to determine whether in fact a warranty situation exists.

Signet Scientific Company is continually making design changes and improvements that adapt to the original circuit configuration. These will be incorporated as required in older units on a minimal charge basis while under warranty.

Consequential Damages

Signet Scientific Company shall not be liable for special consequential damages of any nature with respect to any merchandise or service sold, rendered or delivered.

This warranty gives you specific legal rights and you may also have other rights which vary from state to state.

Notes:

Notes:

Notes:

+GF+ SIGNET

Sales Offices:

- USA** George Fischer, Inc., 2882 Dow Avenue, Tustin, CA 92780/USA,
Tel. (714) 731-8800, Fax (714) 731-6201
- Switzerland** Georg Fischer Rohrleitungssysteme AG, P.O. Box 671, CH-8201 Schaffhausen/Switzerland,
Tel. 052/631 1111, Fax 052/631 2830
- Singapore** George Fischer Pte. Ltd., 15 Kaki Bukit Road 2, KB Warehouse Complex, Singapore 1441,
Tel. 65/747 0611, Fax 65/747 0577
- Japan** Kubota George Fischer, 2-47 Shikitsu Higashi, 1-Chome, Naniwa-Ku, Osaka, 556-91 Japan,
Tel. 816/648 2545, Fax 816/648 2565
- China** George Fischer Ltd., Rm 1503, Business Residence Bldg. of Asia Plaza, 2-3 Bldg. No. 5th
Qu Anzhenxili, Chaoyang Qu, Beijing 100029, P.R. China,
Tel. 86/10 6443 0577, Fax 86/10 6443 0578
- Australia** George Fischer Pty. Ltd., Suite 3, 41 Stamford Road, Oakleigh, Victoria 3166, Australia,
Tel. 61/3 9568 0966, Fax 61/3 9568 0988

**Signet Scientific Company, 3401 Aerojet Avenue, El Monte, CA 91731-2882 U.S.A.,
Tel. (626) 571-2770, Fax (626) 573-2057**



PRINTED ON RECYCLED PAPER

GEORGE FISCHER +GF+ Piping Systems

3-9010.090

E8/98

© Signet Scientific Company 1993

Printed in U.S.A.