



# Installation, Operation & Maintenance Instructions

Install the pump as close as possible to the liquid reservoir from which the liquid is being pumped. As more energy is necessary to prime the liquid than to discharge the fluid, make the suction as short as possible.

## ELECTRICAL

Model M-1/14 and M-1/8 pumps are supplied as standard in a single phase, single voltage, 115V, 50/60c motor with 230V as an option. All other models supplied with a single phase are dual voltage, 115/230V motors. The factory wires all dual voltage motors for the lower voltage (115V) unless otherwise requested. When changing from 115V wiring to 230V wiring, follow the motor manufacturer's wiring instructions, which are found in the motor junction box or motor label. Be sure to wire the motor for clockwise rotation as viewed from the suction entrance of the pump. A power cord and plug are supplied for immediate plug-in operation on motors wired for the lower voltage. These motors have already been wired at the factory for proper rotation. A plug is not supplied on motors

wired 230V. Motors supplied in three-phase are dual voltage, 230/460V, 50/60c which are not wired at the factory. Since direction of rotation cannot be determined without operating the pump, the motor rotation must be checked before operation. Attach leads to motor and bump start. Since these pumps must not run dry for more than 10 seconds, do not leave motor running. As viewed from the suction entrance of the pump, check for clockwise rotation. If counterclockwise rotation, change any two leads and check rotation again. Many options are available on the M Series motors including explosion-proof and special voltage motors. If any of these options are required, please check the motors carefully or consult factory.

## PLUMBING

It is recommended to enlarge the suction line a minimum of one size larger than the suction entrance. Never reduce plumbing on the suction. Avoid 90 degree elbows and never use a 180 degree elbow. Make sure that every suction coupling/connection is airtight. Always use a valve on the discharge of the pump. In case of a flooded suction, in which the liquid

level is higher than the center of the suction entrance, provide a T-connection with a small valve after the discharge valve to assist in letting the air out during flooding. In case of a non-flooded suction, in which the liquid level is lower than the center of the suction entrance, provide a foot valve on the end of the submerged suction line.

## PRIMING

Under flooding conditions, open all the valves in the suction and discharge lines. If a T-connection with valve is provided, wait until the fluid is escaping with no air bubbles. Close all the valves in the discharge line. Always leave the suction valves wide open. A closed suction valve will cause severe damage to the impeller and housing. Under non-flooded conditions, fill up the pump and suction line very slowly from the discharge in order to let entrapped air out. Then close all valves in the discharge line. Give the pump a couple of seconds to build up pressure, then slowly open discharge valve until the desired flow is achieved. A priming chamber can be included as an option to help facilitate priming the pump, but all non-flooded directions must still be followed. If a priming chamber is included, the maximum suction length of the inlet pipe combining both vertical and horizontal lengths is as follows:

Pump Model	Maximum Length of Inlet Pipe
M-1/14, M-1/8, M-1/4	10 feet
M-1/3	7 feet
M-1/2	6 feet

When a flapper valve is supplied on the inlet of the priming chamber, a maximum length of inlet pipe is not required. For proper operation, it is important to note that the liquid being pumped lubricates the impeller-magnet assembly bushing which is spinning on the stationary ceramic spindle. If the pump is run dry for longer than 30 seconds, the impeller bushing may "freeze" onto the spindle. Other bushing materials are available for "dry" running and the factory should be contacted.

## RECOMMENDATIONS

Always make sure there is enough liquid in the reservoir and the level is high enough considering the capacity of the pump unit. Inadequate liquid will cause vortex in the reservoir. A vortex occurs when air mixes from the surface into the fluid. This can disturb the flow and also prevents the pump from priming. Never run the pump for more than 5-10 minutes against a closed discharge valve. This will cause overheating

of the fluid in the pump and will damage the polypropylene parts. Temperature in this case will increase up to 220 degrees. If the pump is being run against a closed discharge valve for a long duration of time, install a small bleed line back into the reservoir before the discharge valve of the pump. If the line is small, there is a minimum pressure loss. This prevents overheating by recirculating the fluid.

## DISASSEMBLY

1. Remove the housing screws (item 13). The entire pump head wet end assembly will now slide out from the drive magnet assembly.
2. The impeller magnet assembly will slide off the spindle.
3. The spindle is a light press fit into the pump housing and can be pulled out by hand.
4. Clean all parts as necessary and replace all worn or damaged parts before re-assembling.

# Recommended Installation

## Suction Plumbing

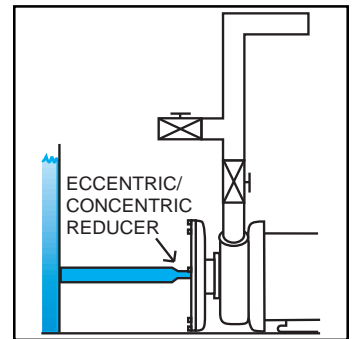
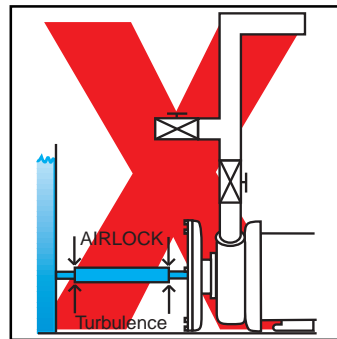
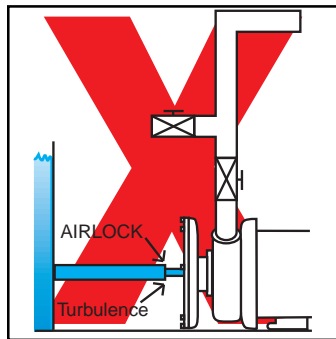
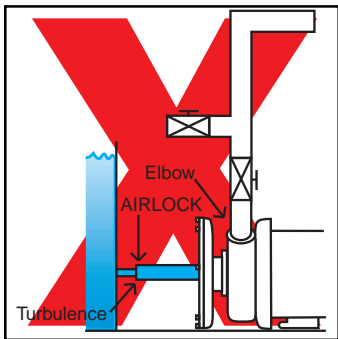

Recommended

## Suction Top View

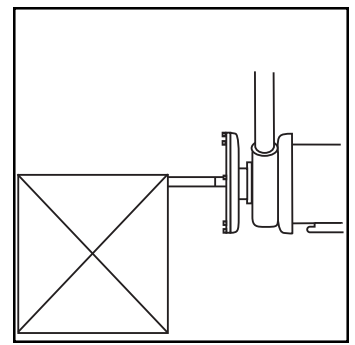
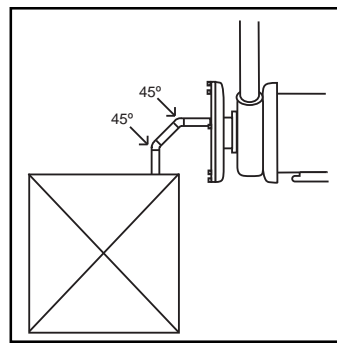
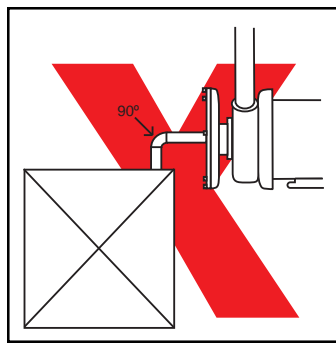
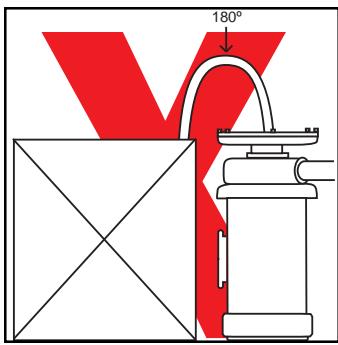

Recommended

Recommended

## Suction Lift

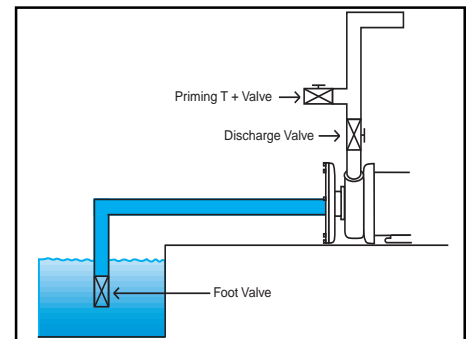
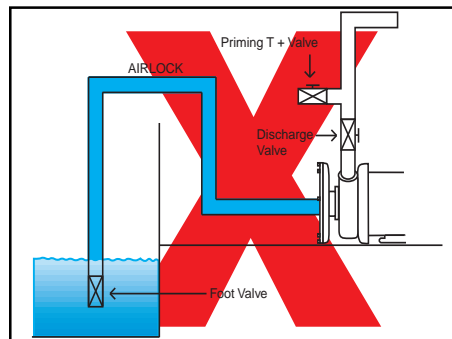
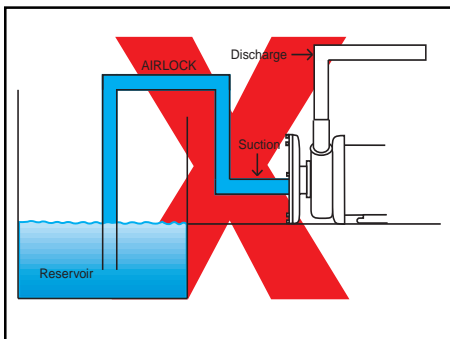

Recommended

## Suction Head

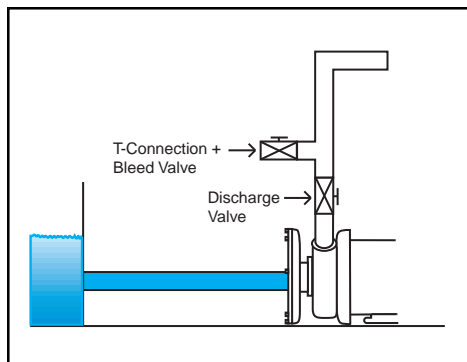
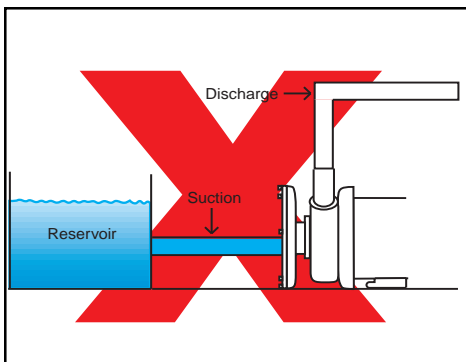

Recommended

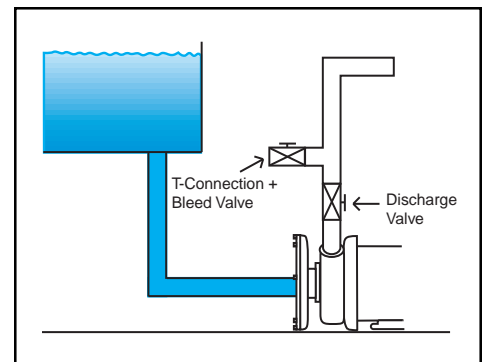

Recommended

# M Spare Parts Drawings

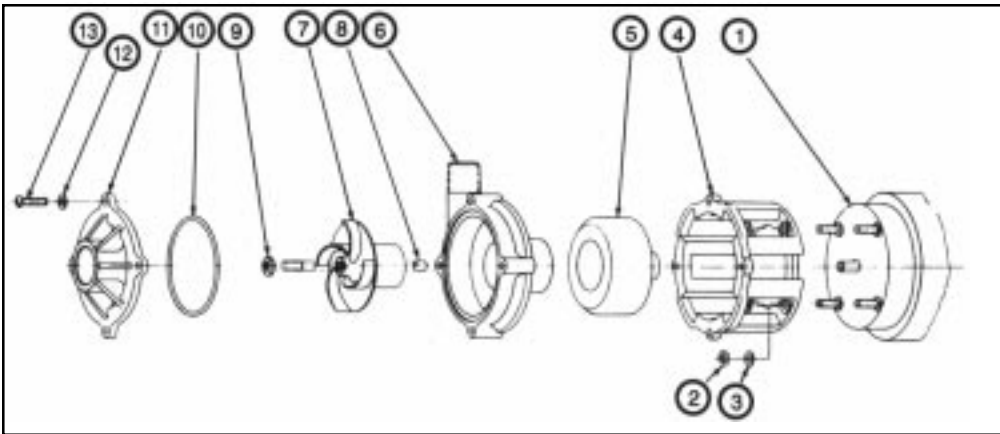

**Model M-1/14**

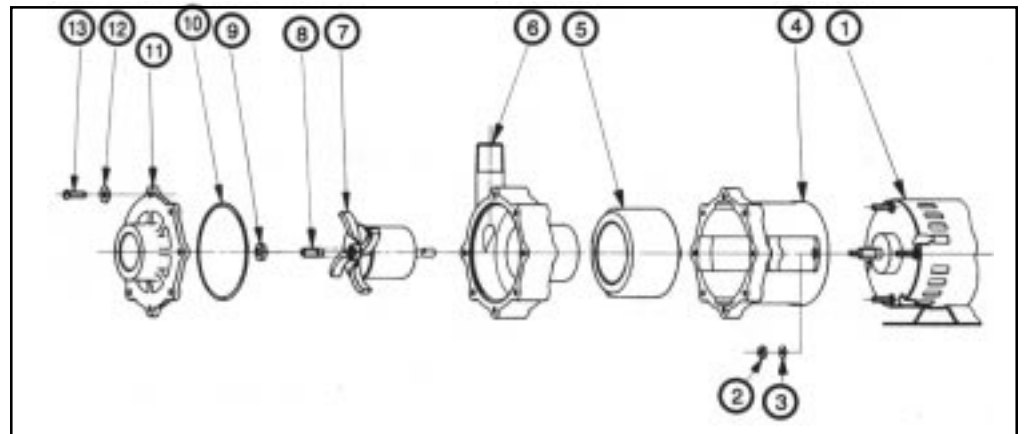

**Model M-1/8**

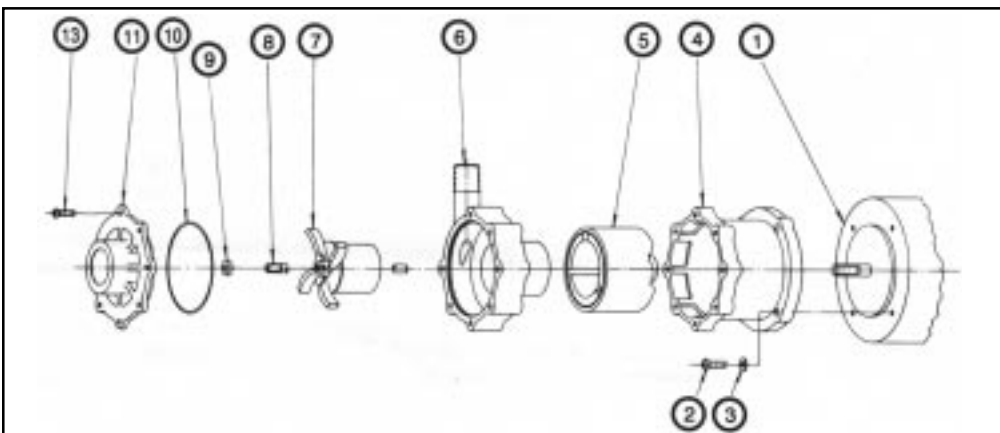

**Model M-1/4**

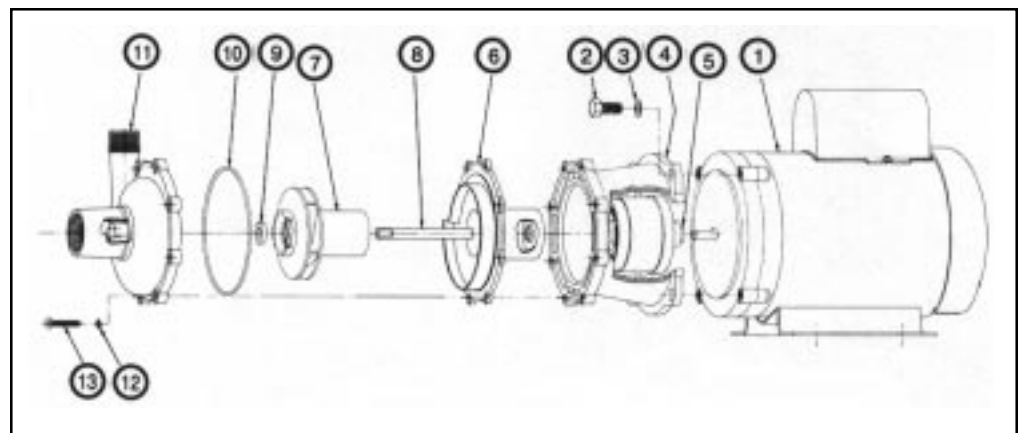

**Model M-1/3**

**Model M-1/2**

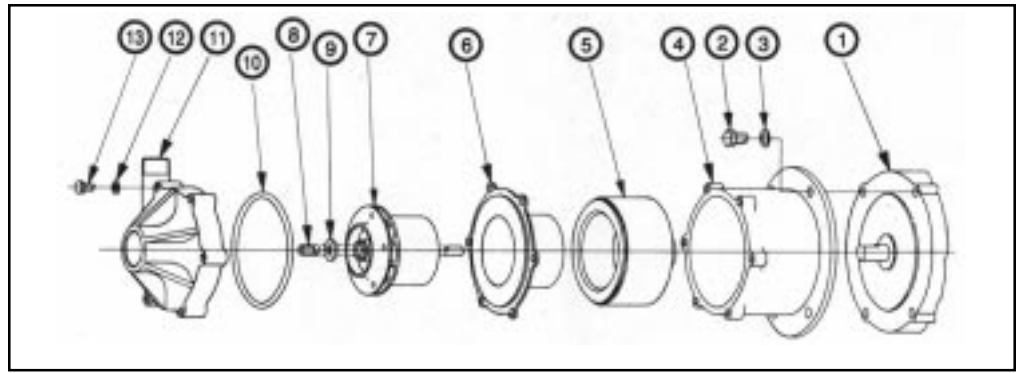

**Model M-3/4**

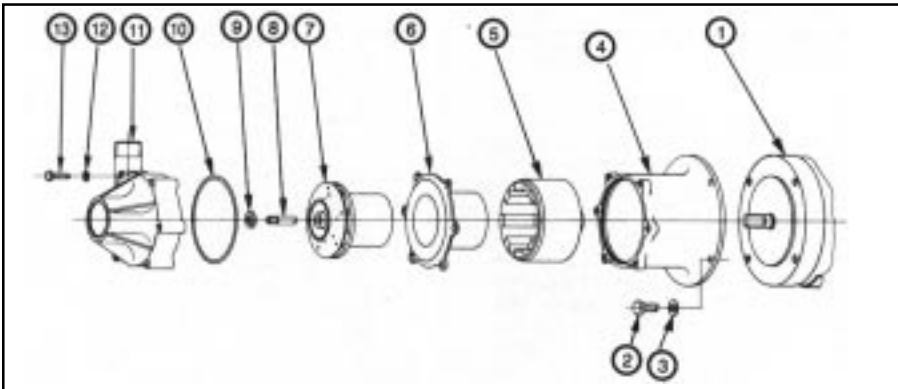

**Model M-2**

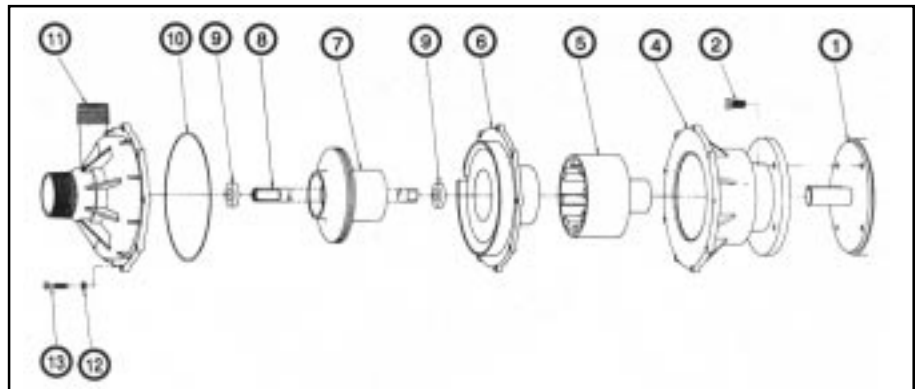

**Model M-3**

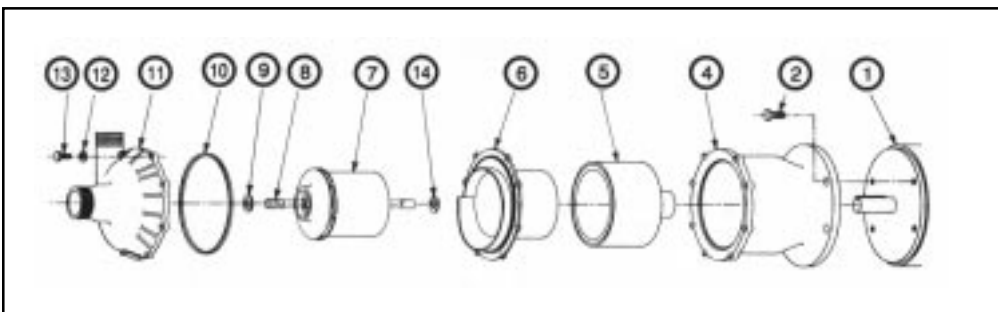

**Model M-10**

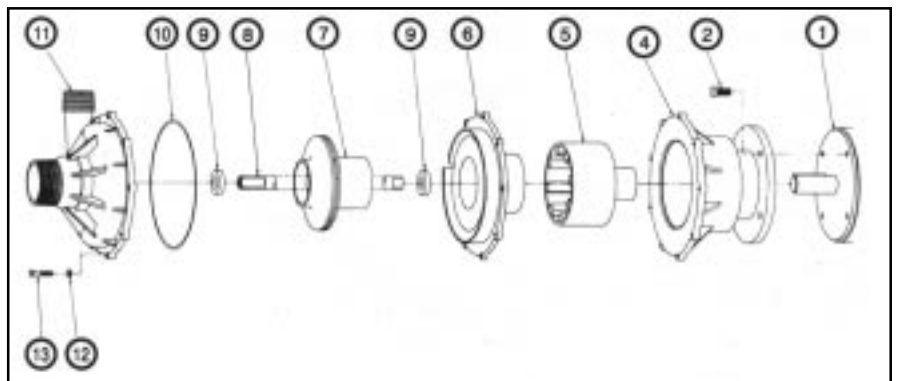

# M Spare Parts List

Item Description	M-1/14 Part No.	M-1/8 Part No.	M-1/4 Part No.	M-1/3 Part No.	M-1/2 Part No.	M-3/4 Part No.	M-2 Part No.	M-3 Part No.	M-10 Part No.
<b>1 Motor (TEFC)</b>									
Phase - Voltage - Cycle									
1 115 50/60	M-130-048-10	M-145-035-10							
1 230 50/60	M-130-049-10	M-145-029-10							
1 115/230 50/60			M-150-090-10	M-151-015-10	M-153-019-10	M-155-016-10			
3 230/460 50/60				M-151-039-10	M-153-020-10	M-155-022-10			
3 230/460 60							M-156-008-10	M-157-012-10*	M-161-012-10
<b>2 Motor/Bracket Hardware</b>									
2A - Nut	M-802-008-10(4)	M-410-039-10(4)							
2B - Washer	M-821-038-10(4)	M-858-004-10(4)	M-150-051-10(4)	M-155-019-10(4)	M-155-019-10(4)	M-155-019-10(4)			
2C - Screw			M-150-050-10(4)	M-155-017-10(4)	M-155-017-10(4)	M-155-017-10(4)	M-150-069-10(4)	M-160-031-10(4)	M-160-031-10(4)
<b>4 Pump/Motor Bracket</b>	M-130-066-01	M-145-010-10	M-150-070-01	M-151-014-01	M-153-001-01	M-155-092-01	M-150-041-01	M-157-008-10	M-161-007-00
<b>5 Drive Magnet Ass'y</b>	M-130-043-03	M-145-027-01	M-150-081-01	M-151-061-01	M-153-035-01	M-155-130-01	M-156-009-01	M-157-005-01	M-161-031-01
<b>6 Impeller Magnet Housing Assy</b>									
6B - Polypropylene	M-130-018-10	M-150-031-10	M-150-031-01	M-151-028-01					
6C - Kynor		M-150-123-01	M-150-123-01	M-151-045-01	M-153-041-01	M-155-124-01	M-156-002-10	M-157-053-10	M-161-009-10
6R - Ryton		M-150-072-01	M-150-072-01		M-153-005-01	M-155-067-01			
6S - Stainless Steel 316			M-150-110-00	M-151-003-00		M-155-035-00		M-157-028-00	
<b>7 Impeller Magnet Assy</b>									
7B - Polypropylene	M-130-069-02	M-145-033-02	M-150-098-02	M-151-029-05					
7B-01 w/teflon-ryton bushing					M-153-003-04	M-155-159-05		M-157-004-02	
7B-02 w/carbon bushing		M-145-033-03	M-150-098-03	M-151-029-08	M-153-003-05	M-155-159-02		M-157-004-05	
7B-31 w/mica-teflon bushing			M-150-098-05	M-151-029-13	M-153-003-09	M-155-159-04		M-157-004-07	
7C - Kynar		M-145-039-02	M-150-125-02	M-151-046-03					
7C-01 w/teflon-ryton bushing								M-157-050-02	
7C-02 w/carbon bushing			M-150-125-03	M-151-046-05	M-153-043-05	M-155-160-02	M-156-004-02	M-157-050-05	M-161-005-04
7C-03 w/mica-teflon bushing			M-150-125-05	M-151-046-11	M-153-043-09	M-155-160-04	M-156-004-03	M-157-050-07	M-161-005-06
7R - Ryton		M-145-034-02	M-150-053-02						
7R-02 w/carbon bushing		M-145-034-03	M-150-053-03						
7R-31 w/mica-teflon bushing			M-150-053-05						
7S - Stainless Steel, 316									
7S-01 w/teflon-ryton bushing				M-151-001-06		M-155-112-03		M-157-029-02	
7S-02 w/carbon bushing			M-150-114-04	M-151-001-04		M-155-112-04		M-157-029-05	
7S-03 w/mica-teflon bushing			M-150-114-06	M-151-001-08		M-155-112-08		M-157-029-07	
<b>8 Spindle</b>									
8C - Ceramic	M-130-024-10	M-130-024-10	M-130-024-10	M-153-007-10	M-153-007-10	M-155-039-10	M-156-007-10	M-157-002-10	M-161-002-10
8S - 316SS	M-939-003-10	M-939-003-10	M-939-003-10			M-155-081-10			
<b>9 Thrust Washer Front</b>									
9C - Ceramic	M-130-028-10	M-130-028-10	M-130-028-10	M-155-009-10	M-155-009-10	M-155-009-10		M-157-001-10	
9S - Hastelloy-C						M-155-084-10		M-157-043-10	
<b>10 Housing Cover O-ring</b>									
10T - Teflon	M-130-080-10	M-135-134-10	M-135-134-10	M-153-024-10	M-153-024-10	M-155-071-10	M-156-023-10	M-157-032-10	M-161-027-10
10V - Viton	M-130-033-10	M-135-023-10	M-135-023-10	M-153-015-10	M-153-015-10	M-155-010-10	M-156-010-10	M-157-011-10	M-161-010-10
<b>11 Pump Housing Cover</b>									
11B - Polypropylene	M-130-021-10	M-150-032-10	M-150-032-10	M-151-027-10		M-155-011-10		M-157-007-10	
11C - Kynor	M-130-111-10	M-150-124-10	M-150-124-10	M-151-044-10	M-153-042-10	M-155-125-10	M-156-001-10	M-157-052-10	M-161-008-10
11R - Ryton		M-150-073-10	M-150-073-10		M-153-002-10				
11S - Stainless Steel 316			M-150-111-00	M-151-002-00		M-155-036-00		M-157-030-00	
Pump Housing Cover Washer	M-150-051-10(4)	M-135-016-10(7)	M-135-016-10(7)	M-155-021-10(6)	M-155-021-10(6)	M-155-021-10(6)	M-157-023-10(8)	M-157-023-10(8)	M-160-030-10(9)
<b>13 Pump Housing Cover Screw</b>	M-823-008-10(4)	M-150-021-10(7)	M-150-021-10(7)	M-151-017-10(8)	M-153-011-10(6)	M-155-014-10(6)	M-157-036-10(8)	M-157-014-10(8)	M-160-029-10(9)
<b>14 Impeller Bushing</b>									
13A Teflon-ryton				M-151-011-10	M-153-016-10	M-155-093-10		M-157-010-10	
13B Carbon		M-150-063-10	M-150-063-10	M-151-009-10	M-153-006-10	M-155-013-10	M-156-025-10(2)	M-157-033-10	M-161-011-10(2)
13C Mica-teflon		M-150-138-10	M-150-138-10	M-151-064-10	M-153-053-10	M-155-147-10	M-156-026-10(2)	M-157-057-10	M-161-032-10(2)
<b>15 Thrust Washer, Rear, Ceramic</b>						M-155-064-10		M-157-009-10	
<b>16 Wet End Assy (standard)</b>									
15B - Polypropylene	M-130-114-01	M-145-046-01	M-150-148-01	M-151-069-01	M-153-056-01	M-155-165-01		M-157-085-01	
15C - Kynar			M-150-149-01	M-151-070-01	M-153-057-01	M-155-166-01	M-156-031-01	M-157-086-01	M-161-035-01

( ) Indicates quantity required other than one (1)

\* Chem Duty available as M-157-089-10



Filter Pump Industries  
7932 Ajay Drive • Sun Valley, CA 91352

Sheet provided by: KTH Sales, Inc. [www.KTHSales.com](http://www.KTHSales.com)