

Series P

Installation & Maintenance

Models:

P-1/15
P-1/6
P-1/4
P-1/2
P-1/2-HP
P-3/4
P-3/4HP
P-1
P-1 1/2
P-2
P-3
P-5
P-7 1/2

Materials:

A - CPVC
B - Polypropylene
C - PVDF



Introduction

Penguin Pumps are designed to handle a large range of chemicals without difficulty. Completely constructed of CPVC, polypropylene, or PVDF, where in contact with the solution being pumped, Series P pumps have an upper working temperature of 180/150/280 degrees, respectively, and thus can handle most corrosive, slurries, and abrasive solutions. Series P pumps are easy to install and operate, and are virtually maintenance-free. All pumps have been tested for proper operation before leaving the factory. To obtain optimum service life, please follow all

Installation & Operation Instructions

Install the pump as close as possible to the reservoir from which the liquid is being pumped. As more energy is necessary to prime the liquid than to discharge the fluid, make the suction as short as possible.

ELECTRICAL

Models P-1/15 and P-1/6 pumps are supplied only in a single phase, single voltage, 115V or 230V, 50/60c motor. All other models supplied with a single phase are dual voltage, 110/220V or 115/230V motors. The factory wires all dual voltage motors for the lower voltage (110/115V) unless otherwise requested. When changing from 110/115V wiring to 220/230V wiring, follow the motor manufacturer's wiring instructions, which are found in the motor junction box. Be sure to wire the motor for counterclockwise rotation as viewed from the suction entrance of the pump. A power cord and plug are supplied for immediate plug-in operation on motors wired for the lower voltage. These motors have already been wired at the factory for proper rotation. A plug is not supplied on motors wired 220/230V. Epoxied motor housings are not available on either voltage motor of the P-1/15 or P-1/6 pumps. All other motor housings are epoxied standard.

An on/off switch is optional only on Models P-1/4 – P-1 1/2 single phase. Motors supplied in three phase are dual voltage, 230/460V, 50/60c, which are not wired at the factory. Since direction of rotation cannot be determined without operating the pump, **the pump head and snap ring must be removed prior to bump starting.** It is imperative that the motor rotation be checked before operation. Attach leads to motor and bump start a maximum of only a couple seconds as if you were turning a light switch on/off as fast as possible. Do not leave motor running. As viewed from the suction entrance of the pump, check for counterclockwise rotation. If clockwise rotation, change any two leads and again check rotation. Replace head and snap ring as described in Assembly. Many options are available on the P Series motors including single phase-50c, explosion-proof, larger horsepower to 7 1/2, and 575V motors. If any of these options are required, please check the motors carefully or consult factory.

PLUMBING

If a suction line or suction extension is required, enlarge the suction line/extension by one size larger than the suction entrance. Never reduce plumbing on the suction. Avoid 90-degree elbows and never use a 180-degree elbow. Make sure every suction coupling/connection is airtight. The bottom of the suction extension should always be at least 2 pipe diameters above the bottom of the tank. In either flooded suction or non-flooded suction, the use of a check valve on the discharge of the pump is recommended. In the case of a non-flooded suction, a flapper check

valve on the end of the submerged suction line must be installed. To facilitate priming the pump, install a T-connection with a small valve between pump case and check valve. It is advisable to use a discharge valve after the check valve. All plumbing and accessories must be supported other than by the pump, in order to prevent possible distortion of the pump case. The use of some hose in the discharge plumbing close to the discharge nozzle of the pump will absorb any movement of the solid plumbing if vibrations exists.

LIQUID LEVEL

The correct liquid level is very important. A liquid level which is too high could cause motor damage.

CHECK THE LIQUID LEVEL. The correct liquid level is halfway

between the bunghole and the centerline of the discharge nozzle.

PRIMING

Under flooded conditions, open all the valves in the suction and discharge lines. Wait a few minutes to let entrapped air out. Close all valves on the discharge line. Leave suction valves wide open. A closed suction valve could cause damage to the impeller and the shaft. Start the pump and crack discharge valves open to let

out any additional entrapped air. Then open valve to desired flow. Under non-flooded conditions, fill up the pump slowly from the T-connection and valve. Then close all valves in the discharge line. Start the pump and continue as flooded conditions.

RECOMMENDATIONS

Always make sure there is enough liquid in the reservoir and the level is high enough, considering the capacity of the pump unit. Inadequate liquid will cause vortex in the reservoir. A vortex occurs when air mixes from the surface into the fluid, which can disturb the flow and also prevents the pump from priming. In cases where the pump is installed outside the reservoir, do not run against a closed discharge valve for more than 5 minutes.

This will cause overheating of the fluid in the pump and will damage the CPVC parts. Temperature in this case will increase up to 220 degrees. If the pump is being run against a closed discharge valve for a long duration of time, install a small bleed line back into the reservoir before the discharge valve of the pump. If the line is small, there is a minimum pressure loss. This prevents overheating by recirculating the fluid.

Recommended Installation

Liquid Level

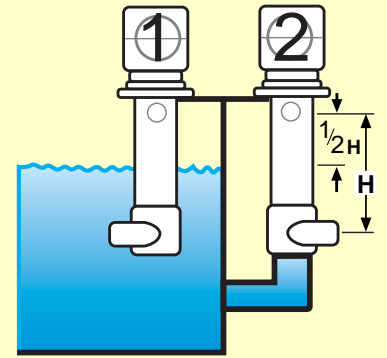
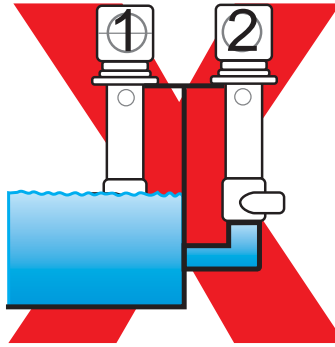
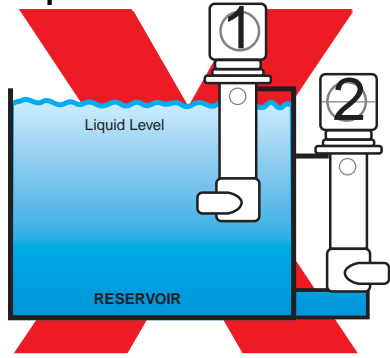

Suction Level

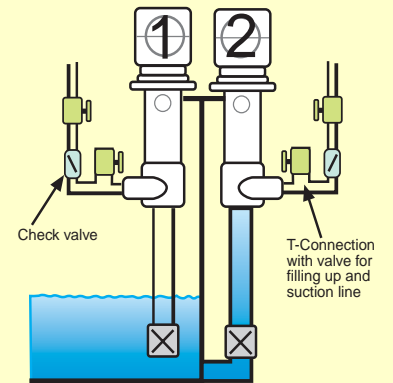
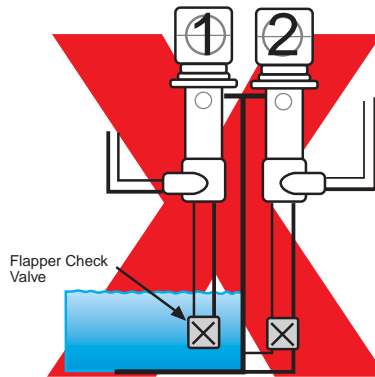
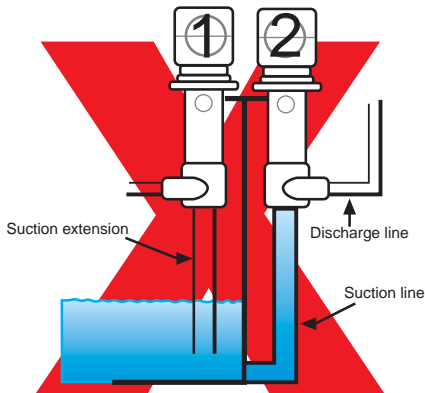

KEY



In-Tank Installation



Out-Of-Tank Installation

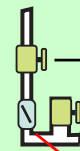

Valve



Check Valve



Flapper Check Valve

Suction Head

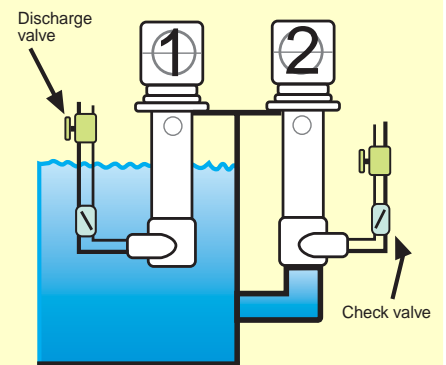
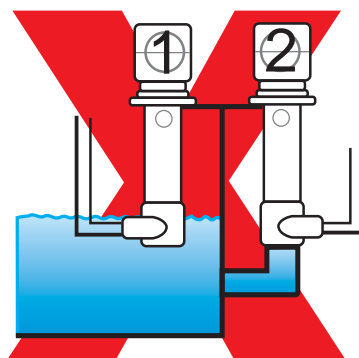

**Recommended installation
for optimal performance
and endurance.**

P-1/6

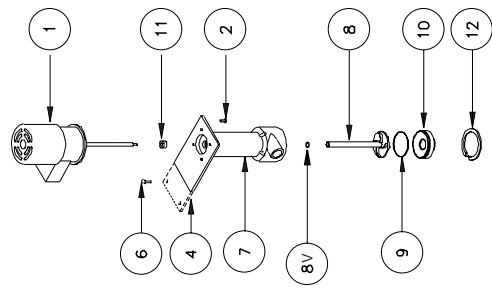

P-1/15

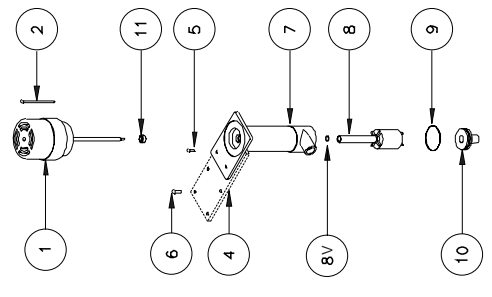

P-1/4, P-1/2, P-3/4

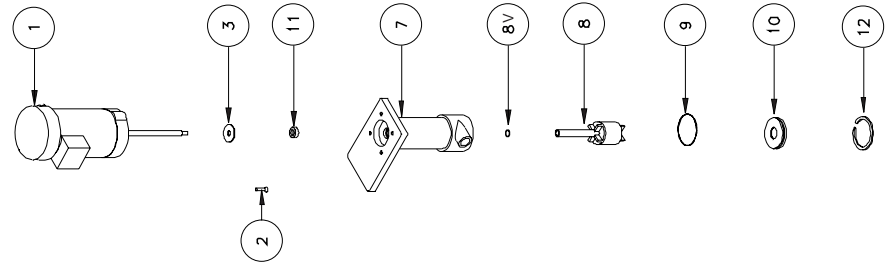

P-1/2-HP, P-3/4-HP
P-1, P-1 1/2, P-2

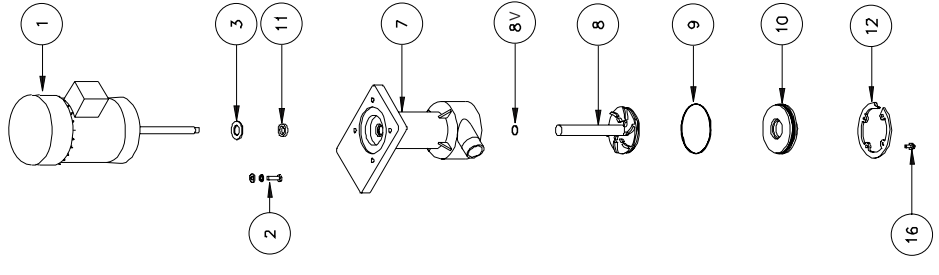

P-3, P-5

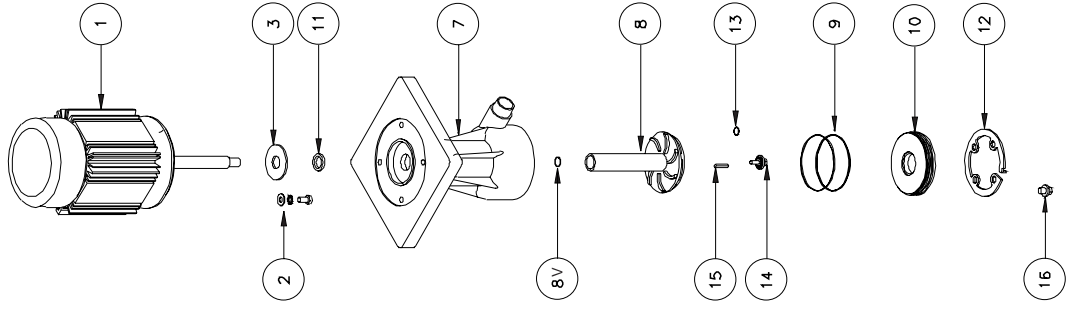

P-7 1/2

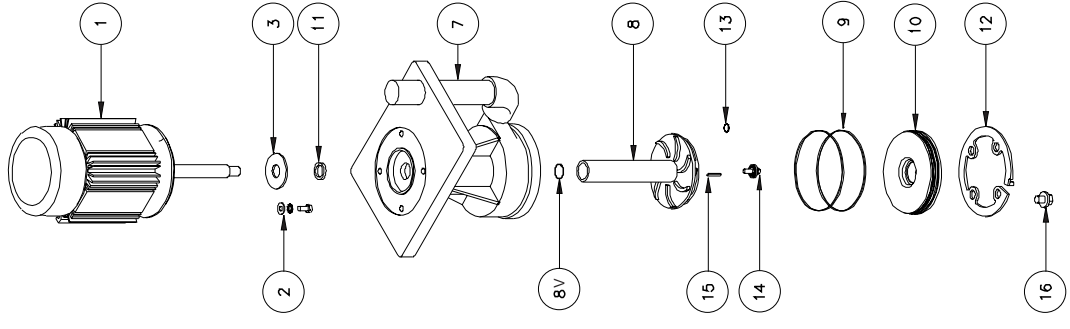

Series P Spare Parts List

Item	Description	P-1/15 Part No.	P-1/16 Part No.	P-1/4 Part No.	P-1/2 Part No.	P-3/4 Part No.	P-1/2-HP Part No.	P-3/4-HP Part No.	P-1 Part No.	P-1 1/2 Part No.	P-2 Part No.	P-3 Part No.	P-5 Part No.	P-7 1/2 Part No.
1	Motor/Shaft Assy													
	Phase-Voltage-Cycle													
1	115 50/60	P-115-01	P-160-01											
1	230 50/60	P-115-21	P-160-21											
1	110/220 50/60			P-140-0103										
	w/ titanium shaft				P-120-0103	P-340-0103	P-120-0103	P-340-0103	P-100-0103					
1	115/230 50/60				P-120-0103	P-340-2103	P-120-2103	P-340-2103	P-100-2103	P-112-2103				
3	230/460 50/60				P-120-3103	P-340-3103	P-120-3103	P-340-3103	P-100-3103	P-112-3103	P-200-3103	P-300-3103K	P-500-3103K	P-712-3103K
	w/ titanium shaft				P-120-3103	P-340-3103	P-120-3103	P-340-3103	P-100-3103	P-112-3103	P-200-3103	P-300-3103K	P-500-3103K	P-712-3103K
1BS	Bearing Set				P-120-01BS	P-120-01BS	P-120-01BS	P-120-01BS	P-120-01BS	P-120-01BS	P-120-01BS	P-120-01BS	P-120-01BS	P-120-01BS
1EF	External Fan w/Set Screw				P-140-01EF	P-140-01EF	P-140-01EF	P-140-01EF	P-120-01EF	P-120-01EF	P-120-01EF	P-120-01EF	P-120-01EF	P-120-01EF
1FC	Fan Cover (w/Drip Shield)				P-140-01FC	P-140-01FC	P-140-01FC	P-140-01FC	P-120-01FC	P-120-01FC	P-120-01FC	P-120-01FC	P-120-01FC	P-120-01FC
	except P-115, P-116													
2	Motor Screw/Bolts/Washer Assy	P-115-02 (2)	P-160-02 (4)	P-140-05 (4)	P-120-05 (4)	P-120-05 (4)	P-120-05 (4)	P-120-05 (4)	P-100-05 (4)	P-120-05 (4)	P-120-05 (4)	P-300-05K (4)	P-300-05K (4)	P-300-05K (4)
3	Slinger			P-140-02	P-120-02	P-120-02	P-120-02	P-120-02	P-100-02	P-120-02	P-120-02	P-300-02	P-300-02	P-300-02
4A	Mounting Bracket- CPVC (A-A/A-S)		P-160-04A											
5	Mounting Bracket Screw	P-115-05 (2)	P-160-05 (2)											
6	Chamber Mounting	P-115-06 (2)	P-160-06 (2)	P-140-06 (2)										
	Screw (A-A/A-S/A-AL)													
7A	Pump Housing Assy-CPVC	P-115-07A	P-160-07A	P-140-07A	P-120-06A	P-120-06A	P-120-06A	P-120-06A	P-100-07A	P-100-07A	P-200-07A	P-300-06AK	P-300-06AK	P-712-06AK
7AL	Mounting Bracket - CPVC(A, AL)			P-140-07AL										
7B	Pump Housing Assy - Polypro	P-115-07B	P-160-07B	P-140-07B	P-120-06B	P-120-06B	P-120-06B	P-120-06B	P-100-07B	P-100-07B	P-200-07B	P-300-06BK	P-300-06BK	P-712-06BK
7C	Pump Housing Assy - PVDF	P-115-07C	P-160-07C	P-140-07C	P-120-06C	P-120-06C	P-120-06C	P-120-06C	P-100-07C	P-100-07C	P-200-07C	P-300-06C	P-300-06C	P-712-06C
8A	Impeller - CPVC	P-115-08A	P-160-08A	P-140-08A	P-120-07A	P-120-07A	P-120-07A	P-120-07A	P-100-08A	P-112-08A	P-200-08A	P-300-07AK	P-500-07AK	P-712-07AK
8AT	w/ titanium insert													
8B	Impeller - Polypro	P-115-08B	P-160-08B	P-140-08B	P-120-07B	P-120-07B	P-120-07B	P-120-07B	P-100-08B	P-112-08B	P-200-08B			
8C	Impeller - PVDF	P-115-08C	P-160-08C	P-140-08C	P-120-07C	P-120-07C	P-120-07C	P-120-07C	P-100-08C	P-112-08C	P-200-08C			
8CT	w/ titanium insert													
8V	Impeller - O-Ring-Viton	N/A	N/A		P-120-07V	P-120-07V	P-120-07V	P-120-07V	P-100-08V	P-120-08V	P-200-08V	P-300-07CK	P-500-07CK	P-712-07CK
9E	Head O-Ring - EPR	P-115-09E	P-160-09E	P-140-09E	P-140-09E	P-140-09E	P-140-09E	P-140-09E	P-100-09E	P-100-09E	P-100-09E	P-300-11E (2)	P-300-11E (2)	P-712-11E (2)
9V	Head O-Ring - Viton	P-115-09V	P-160-09V	P-140-09V	P-140-09V	P-140-09V	P-140-09V	P-140-09V	P-100-09V	P-100-09V	P-100-09V	P-300-11V (2)	P-300-11V (2)	P-712-11V (2)
10A	Head - CPVC	P-115-10A	P-160-10A	P-140-10A	P-120-09A	P-120-09A	P-120-09A	P-120-09A	P-100-10A	P-100-10A	P-200-10A	P-300-10A	P-300-10A	P-712-10A
10B	Head - Polypro	P-115-10B	P-160-10B	P-140-10B	P-120-09B	P-120-09B	P-120-09B	P-120-09B	P-100-10B	P-100-10B	P-200-10B	P-300-10B	P-300-10B	P-712-10B
10C	Head - PVDF	P-115-10C	P-160-10C	P-140-10C	P-120-09C	P-120-09C	P-120-09C	P-120-09C	P-100-10C	P-100-10C	P-200-10C	P-300-10C	P-300-10C	P-712-10C
11V	Lip Seal Assy - Viton	P-115-11V	P-160-11V	P-140-11V	P-120-11V	P-120-11V	P-120-11V	P-120-11V	P-100-11V	P-120-11V	P-200-11V	P-300-13V	P-300-13V	P-300-13V
12A	Snap Ring - CPVC	P-160-11A	P-160-11A	P-140-11A	P-120-08A	P-120-08A	P-120-08A	P-120-08A	P-100-11A	P-100-11A	P-100-11A	P-300-12A	P-300-12A	P-712-12A
12B	Snap Ring - Polypro	P-160-11B	P-160-11B	P-140-11B	P-120-08B	P-120-08B	P-120-08B	P-120-08B	P-100-11B	P-100-11B	P-100-11B	P-300-12C	P-300-12C	P-712-12C
12C	Snap Ring - PVDF	P-160-11C	P-160-11C	P-140-11C	P-120-08C	P-120-08C	P-120-08C	P-120-08C	P-100-11C	P-100-11C	P-100-11C	P-300-08VK	P-300-08VK	P-300-08VK
13V	Impeller Nut O-Ring - Viton													
14A	Impeller Nut Assy - CPVC													
14AT	w/ titanium insert													
14C	Impeller Nut Assy - PVDF													
14CT	w/ titanium insert													
15T	Shaft Key - Titanium													
16A	Snap Ring Screw - CPVC				P-100-16A*	P-100-16A*	P-100-16A*	P-100-16A*	P-100-16A*	P-100-16A*	P-100-16A*	P-300-16A	P-300-16A	P-712-16A
16B	Snap Ring Screw - Polypro				P-100-16B*	P-100-16B*	P-100-16B*	P-100-16B*	P-100-16B*	P-100-16B*	P-100-16B*	P-300-16B	P-300-16B	P-712-16B
16C	Snap Ring Screw - PVDF				P-100-16C*	P-100-16C*	P-100-16C*	P-100-16C*	P-100-16C*	P-100-16C*	P-100-16C*	P-300-16C	P-300-16C	P-712-16C
17A	Pump Head Assy - CPVC	P-115-12A	P-160-13A	P-140-13A	P-120-12A	P-120-12A	P-120-12A	P-120-12A	P-100-13A	P-112-13A	P-200-13A	P-300-14AK	P-500-14AK	P-712-14AK
17AT	w/ titanium													
17B	Pump Head Assy - Polypro	P-115-12B	P-160-13B	P-140-13B	P-120-12B	P-120-12B	P-120-12B	P-120-12B	P-100-13B	P-112-13B	P-200-13B	P-300-14BK	P-500-14BK	P-712-14BK
17BT	w/ titanium													
17C	Pump Head Assy - PVDF	P-115-12C	P-160-13C	P-140-13C	P-120-12C	P-120-12C	P-120-12C	P-120-12C	P-100-13C	P-112-13C	P-200-13C	P-300-14CK	P-500-14CK	P-712-14CK
17CT	w/ titanium													

* = Includes viton O-ring

Maintenance Instructions

NOTE: This manual covers several different configurations of P-Series pumps. Be sure to select the appropriate model number for your pump.

MODEL: P-1/15

DISASSEMBLY

1. Insert a screwdriver through the center hole at the end of the housing to remove the head. Pull with a rocking motion to remove. Head O-ring can easily be replaced.
2. Unscrew the three (3) fan cover screws and remove the fan cover. With the pump in a horizontal position, hold the fan with one hand or insert a screwdriver in the center motor slot and unscrew the impeller counterclockwise using fingers or the handle end of a pair of pliers.
3. Placing the pump vertical with the motor on top, carefully bend down one fan blade in order to expose the motor screw. Remove motor screw. Rotate the fan 180 degrees to expose second motor screw and remove. Motor and housing are now separated. Do not try to remove shaft as this is an integral piece with the motor rotor. Lip seal can be replaced.

ASSEMBLY

1. (New Motor) Remove fan cover and bend down one fan blade. (See Disassembly). Remove existing motor screws from new motor and exchange with screws from motor being replaced.
2. With the housing in a vertical position, mounting bracket on top, place motor shaft into housing. The cord should be 180 degrees from the outlet. Screw the motor screws into the holes at the top of the pump housing. The motor screws should not be overtightened.
3. Insert the impeller into the housing. With one hand on the fan and the other on the impeller, turn the impeller clockwise with fingers or handle end of a pair of pliers until impeller bottoms out.
4. Place the pump upright resting on the motor. Look down into the housing and, while rotating the impeller, check to see that the impeller is centered. The impeller must not be touching the side of the housing. If the impeller is not centered, hold the motor with one hand and tap the housing with the mallet in the direction necessary to clear the housing.
5. Finish screwing the two motor screws. Bend fan blade back to normal position. Replace the fan cover. Insert the three (3) fan cover screws and tighten. Spin the impeller to check that the fan is not rubbing against the cover and fan blade is properly in place. (Do not operate pump until motor fan and pump impeller have been checked for position.)
6. Wet head and head O-ring. Be sure head O-ring is properly in place. Place head and head O-ring into housing. The threaded nipple should be tapped with a mallet until bottoming out in the housing.

MODEL: P-1/6 P-1/4 P-1/2 P-3/4

DISASSEMBLY

1. Remove the front snap ring at the end of the housing using a screwdriver or a pair of pliers.
2. Insert appropriate threaded pipe through the center hole at the end of the housing to remove the head. Pull with a rocking motion to remove. Head O-ring can easily be replaced.
3. Take the plug out from the back of the fan cover or drip shield. Insert a screwdriver in the slot of the motor shaft and unscrew the impeller counterclockwise using fingers or the handle end of a pair of pliers.
4. Remove the four (4) motor bolts located beneath the motor bracket. Motor and housing are now separated. Do not try to remove shaft as this is an integral piece with the motor rotor. Slinger and lip seal can be replaced.

ASSEMBLY

1. With the motor in a vertical position, shaft upwards, place housing over shaft, lining up motor bolt holes in mounting bracket with holes in the motor. Be sure the slinger is properly placed. Conduit box should be 180 degrees from the outlet. Screw the motor bolts into the holes beneath the mounting bracket in a diagonal sequence. Be sure motor screws are tight.
2. Insert the impeller into the housing. With one hand holding a screwdriver in the slot of the motor shaft and the other on the impeller, turn the impeller clockwise with fingers or handle end of a pair of pliers until impeller bottoms out.
3. Place the pump upright resting on the motor. Look down into the housing and while rotating the impeller, check to see that the impeller is centered. The impeller must not be touching the side of the housing.
4. Replace plug in the back of the fan cover or drip shield.
5. Wet head and head O-ring. Be sure head O-ring is properly in place. Insert appropriate threaded pipe into head and replace into housing. The threaded pipe should be tapped with a mallet, pushing the head into the housing until it bottoms out. On Models P-1/2 and P-3/4, push the head into the housing until snap ring groove is exposed. Remove pipe

Maintenance Instructions

NOTE: This manual covers several different configurations of P-Series pumps.
Be sure to select the appropriate model number for your pump.

MODEL: P-1/2-HP P-3/4-HP P-1 P-1 1/2 P-2

DISASSEMBLY

1. Remove the four (4) snap ring screws, being careful not to lose the O-rings. Now the snap ring can be removed using a screwdriver or a pair of pliers.
2. Insert the appropriate threaded pipe through the center hole at the end of the housing to remove the head. Pull with a rocking motion to remove. Head O-ring can easily be replaced.
3. Take the plug out from the back of the fan cover or drip shield. Insert a screwdriver in the slot of the motor shaft and unscrew the impeller counterclockwise using fingers or the handle end of a pair of pliers.
4. Remove the four (4) motor bolts located beneath the motor bracket. Motor and housing are now separated. Do not try to remove the shaft as this is an integral piece with the motor rotor. Slinger and lip seal can be replaced.

ASSEMBLY

1. With the motor in a vertical position, shaft upwards, place housing over the shaft, lining up motor bolt holes in the mounting bracket with holes in the motor. Be sure the slinger is properly in place. Conduit box should be 180 degrees from the outlet. Screw the motor bolts into the holes beneath the mounting bracket in a diagonal sequence. Be sure motor screws are tight.
2. Insert the impeller into the housing. With one hand holding a screwdriver in the slot of the motor shaft and the other hand on the impeller, turn the impeller clockwise with fingers or the handle end of a pair of pliers until the impeller bottoms out.
3. Place the pump upright resting on the motor. Look down into the housing, and while rotating the impeller, check to see that the impeller is centered. The impeller must not be touching the side of the housing.
4. Replace plug in the back of the fan cover or drip shield. Wet head and head O-ring. Be sure head O-ring is properly in place. Insert the appropriate threaded pipe into head and replace in housing. The threaded pipe should be tapped with a mallet, pushing the head into the housing until the snap ring groove is exposed. Remove pipe and replace snap ring. Line up through holes in the snap ring with the threaded holes in the head by rotating the snap rings counterclockwise. Insert and tighten the four (4) snap ring screws.

MODEL: P-3 P-5 P-7 1/2

DISASSEMBLY

1. Remove the four (4) snap ring screws. Now the snap ring can be removed using a screwdriver or a pair of pliers.
2. Insert a 2 inch threaded pipe through the center hole at the end of the housing to remove the head. Pull with a rocking motion to remove. Head O-rings can easily be replaced.
3. Unscrew the fan cover screws and remove the fan cover and drip shield. Place the screwdriver between fan blades and unscrew the impeller nut using a 3/4 inch open wrench in a counterclockwise rotation. Impeller nut O-ring can be replaced.
4. With the pump in a vertical position, impeller up, place a screwdriver through the discharge port wedging between the impeller top and the housing. Carefully lift the impeller and remove. If impeller does not remove easily, proceed to step 5.
5. Remove the four (4) motor bolts located beneath the motor bracket. Motor and housing are now separated. Do not try to remove shaft as this is an integral piece with the motor rotor. Slinger and lip seal can be replaced. Using a rubber mallet hit the pump bracket lightly, top side facing motor, until the impeller and keyway pop loose.

ASSEMBLY

1. With the motor in a vertical position, shaft upwards, place housing over shaft, lining up motor bolt holes in the mounting bracket with holes in the motor. Be sure the slinger is properly in place. Screw the motor bolts into the holes beneath the mounting bracket in a diagonal sequence.
Be sure motor screws are tight.
2. Insert the impeller into the housing until it bottoms out. Do not hammer the impeller and sleeve down on the shaft. Line up the keyway and insert key by lightly tapping it with a hammer. Screw the impeller nut clockwise holding impeller. Be sure impeller nut O-ring is properly in place. After handtight, turn with wrench 180 degrees.
DO NOT OVERTIGHTEN.
3. Replace the fan cover and drip shield. Insert the fan cover screws and tighten. Be sure fan is not rubbing against fan cover.
4. Place the pump upright resting on the motor. Look down into the housing and, while rotating the impeller, check to see that the impeller is centered. The impeller must not be touching the side of the housing.
5. Wet head and head O-rings. Be sure head O-rings are properly in place. Insert 2 inch threaded pipe into the head and replace in housing. The threaded pipe should be tapped with a mallet, pushing the head into the housing until the snap ring groove is exposed. Remove pipe and replace snap ring. Line up through holes in snap ring with the threaded holes in the head by rotating the snap ring counterclockwise. Insert and tighten the four (4) snap ring screws.

**Sealless In-Tank Pumps
Series P**

Flows to 175 gpm

Corrosion-resistant CPVC, polypropylene or PVDF construction. No metal contact. No pump bearings, bushings or seals. Self priming when immersed. Runs dry without damage. Temperatures to 250°F.

Bulletin 201



Model P-7 1/2AK

**CPVC 2-stage and 3-stage
Horizontal Diffuser Pumps
Series HD**

Flows to 104 gpm

Pressure to 150 TDH in feet

A multi-stage pump in plastic. Designed for higher pressure applications, where a metal pump is not acceptable. CPVC construction and optional titanium shaft allows for temperatures to 180°F. Multi-stage pumps are available in 2-stage and 3-stage in 1 1/2hp, 2 hp, and 3hp. Series HD offers increased efficiency with smaller pump cases.

Bulletin 206



Model HD-2-3V

**CPVC Horizontal
Centrifugal Pumps
Series HV & HN**

Flows to 181 gpm

True volute design featuring the latest hydraulic technology -- energy efficiency, high flow and high pressure. CPVC construction where in contact with solution. No metal contact. All models available with double mechanical seal and water flush. Temperatures to 180°F. Optional priming chambers available for Series HV.

Bulletin 202/210



Model HV-3/4DV



Model HN-5S

**Polypropylene Horizontal
Centrifugal Pumps
Series HOM**

Flows to 132 gpm

These glass fiber reinforced polypropylene pumps with a simple energy-saving volute design offer easy maintenance and high operational efficiency. Ideal for many OEM and chemical processing applications. A completely metalless diplo seal provides reliability and easy installation. The V-clamp with knob allows for easy assembly and disassembly.

Bulletin 209



Model HOM-1/2E

**Sealless Magnetic Drive
Pumps
Series M & MT**

Flows to 250 gpm

Corrosion resistant, leakproof, sealless magnetic drive pumps with flows to 200 gpm. Series M constructed of polypropylene and/or ryton with optional 316SS, Kynar or Hastelloy construction. Series MT pumps are constructed of polypropylene or PVDF and can handle caustics to 220°F. Compatible with a wide range of acids and alkalis.

Bulletin 203/213



Model M-3/4B



Model MT-2C

**316 Stainless Steel
Centrifugal Pump
Series HSC**

Flows to 140 gpm

Corrosion resistant, stainless steel pumps ideal for many OEM and chemical processing applications. They feature high operational efficiency and easy maintenance, and are available with a single mechanical seal or double mechanical seal with water flush. Multi-stage model also available for high pressures to 140 TDH.

Bulletin 208



Model HSC-1/2SV



Filter Pump Industries

7932 Ajay Drive • Sun Valley, CA 91352